

# LS Series Mechanical Level Switch Buoyancy Level Switch

Liquid point-level detection  
switch  
K-TEK Products







## Features

- Rugged and robust chamber design for demanding applications
- One step switch point adjust
- Precision fabricated floats and displacers
- Compact switching mechanism eliminates bulky housing and traditional bias springs
- Easily retrofitted to most competitor models
- Eight standard designs and six compact switching mechanisms

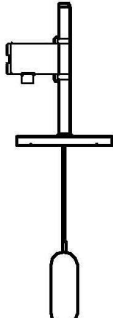
# LS Series

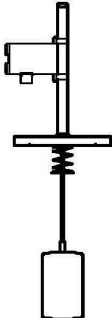
**ABB's LS Series Mechanical Level Switches** are the most rugged and durable liquid point-level detection products in the industrial marketplace today. **ABB** innovations such as the one-step switch point adjust and the hermetically sealed/dual compartment switching mechanism have eliminated the need for bulky housing covers that are associated with cracking, moisture ingress, high temperature fatigue, and ultimately switch failure. This configuration guide contains general guidelines and ordering data that will assist you in selecting the best float or displacer operated switch for your specific fluid level application. These switches are available in flanged or sealed chambers or as insertion models. ABB has over 100 configurations available.

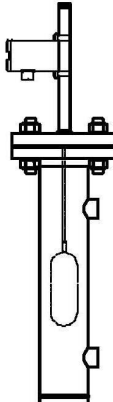
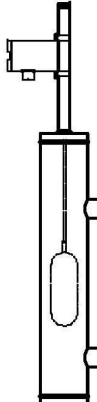
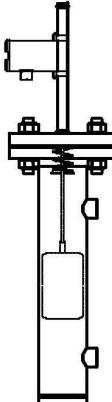
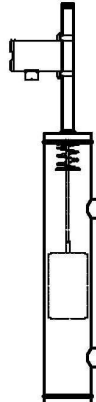
 <p>LS 500 FLANGED TOP MOUNT FLOAT</p>	 <p>LS 510 MNPT TOP MOUNT FLOAT</p>	 <p>LS 550 FLANGED TOP MOUNT DISPLACER</p>	 <p>LS 560 MNPT TOP MOUNT DISPLACER</p>
 <p>LS 600 FLANGED CHAMBER FLOAT</p>	 <p>LS 700 SEALED CHAMBER FLOAT</p>	 <p>LS 800 FLANGED CHAMBER DISPLACER</p>	 <p>LS 900 SEALED CHAMBER DISPLACER</p>

## General

- Over 10,000 global installations in applications ranging from condensate to CO<sub>2</sub> to crude oil
- Easily retrofitted to most competitor models
- Designed to handle specific gravities as low as 0.25, temperatures as high as 1000° F (538° C), and pressures up to 4500 psi (310 bar)
- Choose from eight (8) standard designs and six (6) different switching mechanisms
- Worldwide delivery
- Five year manufacturer warranty

## Chambers

- Choices for chamber material include: Carbon Steel, 316 Stainless Steel, Duplex Stainless Steel, Hastelloy C-276, Hastelloy B-3, and P11 and P91 Chrome Molly Steel.
- Flanged models have standard slip-on “top access connection” flanges. Weld-neck flanges are optional.
- Designed to guidelines of ASME B31.1 and B31.3
- All welders and fabrication procedures are qualified and maintained per ASME
- Certification to NACE MRO175 and MRO103 is available

## Sensing Elements

- Each float and displacer is precision fabricated to indicate true fluid level.
- Choices for float and displacer materials include: 316 Stainless Steel, Hastelloy C-276, and Titanium (Grades 2 and 5). Ceramic is also available for displacers.

## Process Connections

- A wide variety of process connection types include: Flanges (slip-on, weld-neck), Socket Weld, and Threaded (NPT)
- Available flange ratings and sizes include: ASME, DIN, HG, and most International and customer specified flange types

## Switching Mechanisms

- All stainless steel housing construction with NEMA 4X ratings
- Temperature ratings available from -320°F (-190°C) to 1000°F (538°C)
- Choices for switching mechanism types include: Reed, Cam Action, and Pneumatic
- Available switching mechanisms are hermetically sealed, standard open contacts, or pneumatic contacts
- Agency Listings for most switches include: FM, CSA, and ATEX

## Options

- Custom Calibration and Switch Point
- High Temperature and Cryogenic Insulation
- Steam Tube and Electrical Heat Tracing
- Vent, Drain, and Process Isolation Valves
- Stilling Wells and Support Tubes for Turbulent Conditions

## Quality Certifications

- ABB is the only level gauge manufacturer in North America to hold the following certifications: ASME (U, S, and UM Stamps), PED, and National Boiler Certification

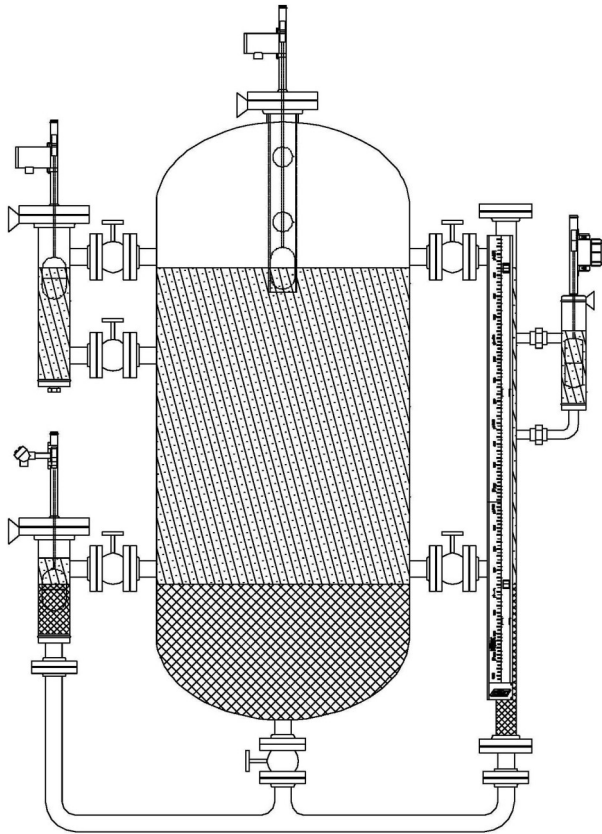

**A  
P  
P  
L  
I  
C  
A  
T  
I  
O  
N  
S**

**OIL AND GAS**

- Separator levels

**PETROCHEMICAL**

- Catalytic Cracker
- Distillation
- Fractionation
- Hydrotreater/Reformer
- Coker
- Flare Knockout Tank

**POWER**

- Fuel Storage
- Steam Turbine Drip Legs
- Hotwell Condenser
- Feed Water Heaters
- Demineralization Tanks
- Ash Precipitator/Scrubber
- Steam Drum Level
- Lube Oil Systems

**CHEMICAL & OTHER**

- Storage & Batch Tank Level
- High Level Alarm Safety Shutdown
- Water/Wastewater Treatment Tanks
- Pulp Processing Tanks
- Lube Oil Tanks
- Sump Control

**LS Series Description and Operation Basics**

The LS Series is a single or multi point, fluid-level switch. The device consists of a float (or displacer) with an attached magnet and a switch post to house the moving magnet and to support the switch mechanism. The switch post is mounted on either a top entry process connection or to the top of a mechanical cage or chamber. Process connections are typically flanges, NPT, or socket weld connections. Chambers have connections on the side and/or bottom to attach to the side of a tank. Movement of the float (or displacer) is typically limited to the range required to activate the switch mechanism at a specified level.

The LS Series can be a float or displacer operated, magnetically coupled level switch. As the fluid level in the vessel rises or falls, the position of the float or displacer changes with it. Magnets inside the switch post, attached to the float or displacer, move with the changing level as well. A switch mechanism, attached to the exterior of the switch post, detects movement of the magnet past its location, and transfers the contact positions. Use of the LS Series instead of the conventional “bulky housing” cage switch allows easy access to the switch mechanism and there are no seals or diaphragms to wear out. Installation of isolation valves on the inlet and outlet of the chamber allows removal of the entire unit without draining the vessel.

<b>Section</b>	<b>Page</b>
<b>Quality Manufacturing</b>	
Switch Mechanism Comparison	6
Chamber Comparison	7
<b>Fundamentals</b>	
Float Switches	8
Displacer Switches	8
<b>How to Order</b>	9
<b>Float Switches</b>	
500/510 Series - Top Mount Float	10
600 Series - Flanged Chamber Float	15
700 Series - Sealed Chamber Float	27
<b>Displacer Switches</b>	
550/560 Series - Top Mount Displacer	11
800 Series - Flanged Chamber Displacer	21
900 Series - Sealed Chamber Displacer	33
<b>Switching Mechanisms and Housings</b>	
Switches	39
<b>Accessories</b>	
High Temperature & Cryogenic Isolation Insulation	41
Vent, Drain & Process Isolation Valves	42
Stilling Wells & Support Tubes	43
<b>Appendix</b>	
Pipe Pressure Ratings (Table 1)	44
Flange Pressure Ratings (Table 2)	46
Process Connection Configuration (Tables 3 & 4)	47
Conversions (Table 5)	51

## Switching Mechanism Comparison

The ABB standard switching mechanism is a magnetically actuated double pole double throw (DPDT) switch. ABB offers a variety of magnetically actuated switch mechanisms (reed, cam-action and pneumatic style) with SPDT, DPDT, or pneumatic outputs. When a ABB switch mechanism (single or multiple) is mounted on a LS Series mechanical switch, it can sense a high or low level within a vessel. The unique magnetic coupling action eliminates the need for seals, diaphragm springs, or torque tubes because there is no physical contact with the process. The switch configuration also has no process connections which ensures complete isolation from the process. The 360° adjustable switch mechanism does not require the removal of the conventional bulky cover and can be easily positioned at the desired switch point. The compact, maintenance free design, requires no periodic cleaning or operational checks and contains hermetically sealed contacts that ensure high reliability and extended product life.



ABB uses high quality design, ASTM materials and ASME construction to provide a significantly higher standard product than our competition. With ABB products, a customer never needs to worry if they are getting a good design—all standard products meet the following criteria as a minimum.



**ABB Standard Chamber**

**Other Manufacturer's Chamber**

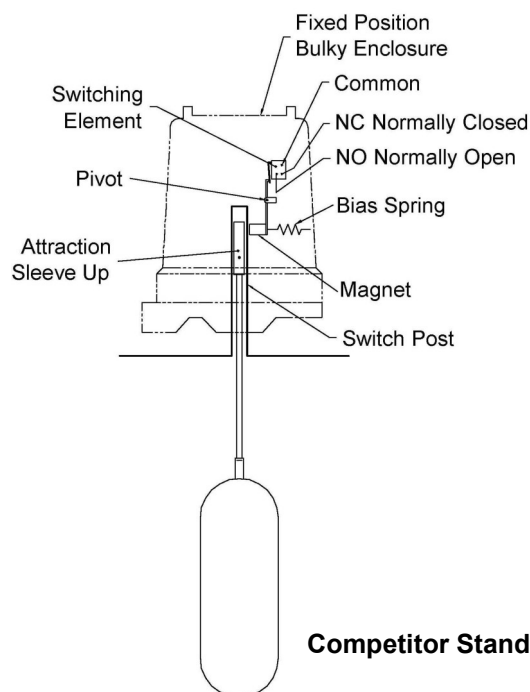
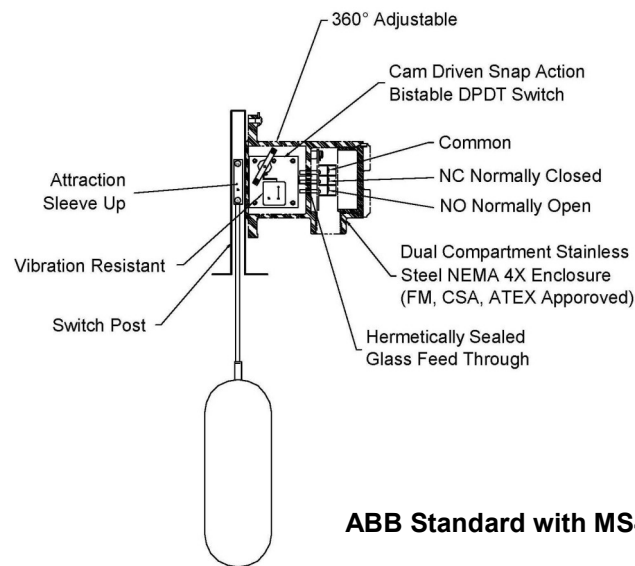
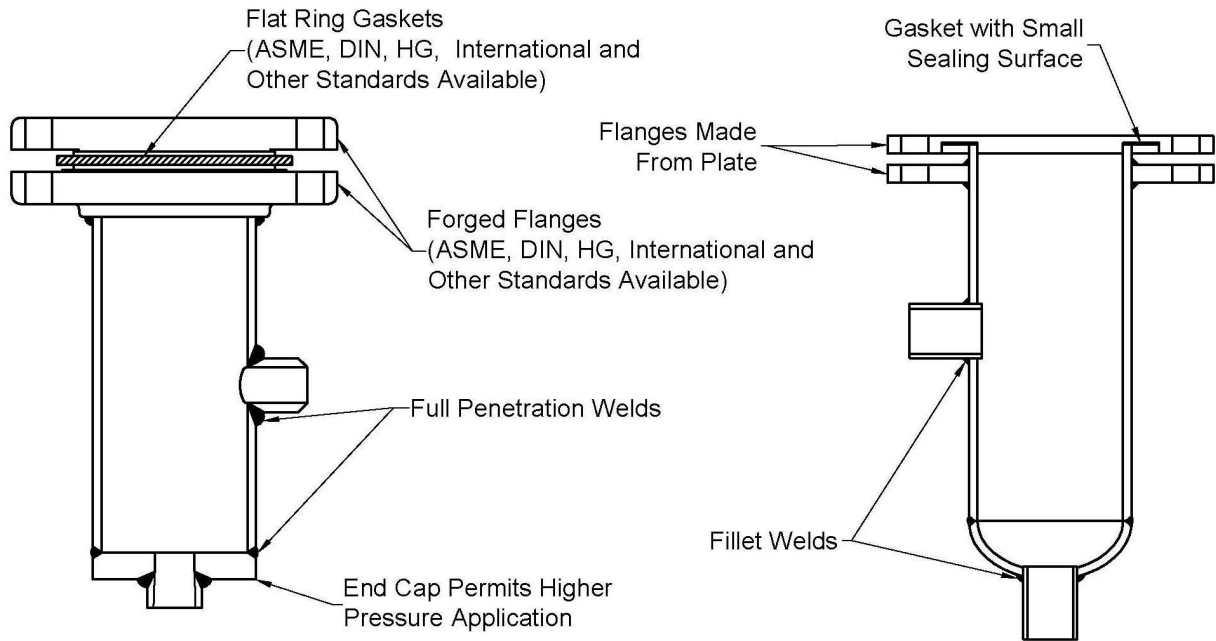
ABB is the **only** North American level instrument company holding ASME, PED and National Boiler certifications. Any LS Series can be manufactured to following certifications and/or most customer specific supplied standards



U # 26,831 Manufacturer of Pressure Vessels  
 UM #26,832 Manufacturer of Miniature of Pressure Vessels  
 S #26,830 Manufacturer and Assembly of Power Boilers  
 B31.1 Power Piping  
 B31.3 Process Piping



Pressure Equipment Directive (97/23/EC)  
 #DGR-0036-QS-166-02



Authorized to apply the 'NB' mark and register boilers, pressure vessels, or other pressure retaining items with the National Board in accordance with its provisions. Scope of Authorization is in reference to ASME Stamps S and U.

## Float Operated Level Switches Model Series 500, 510, 600, 700

The float rides on the process fluid and tracks with the liquid level movement. As the fluid level in the vessel (or external cage) rises or falls, the position of the float changes. Magnets attached to a float guide rod (located inside the sensing tube) also move with the changing level. A switch mechanism (electrical or pneumatic) attached to the exterior of the sensing tube is actuated by a rising level and de-actuated by a falling level.

Floats can utilize multiple switching mechanisms. Consult the factory for special float switching arrangements.

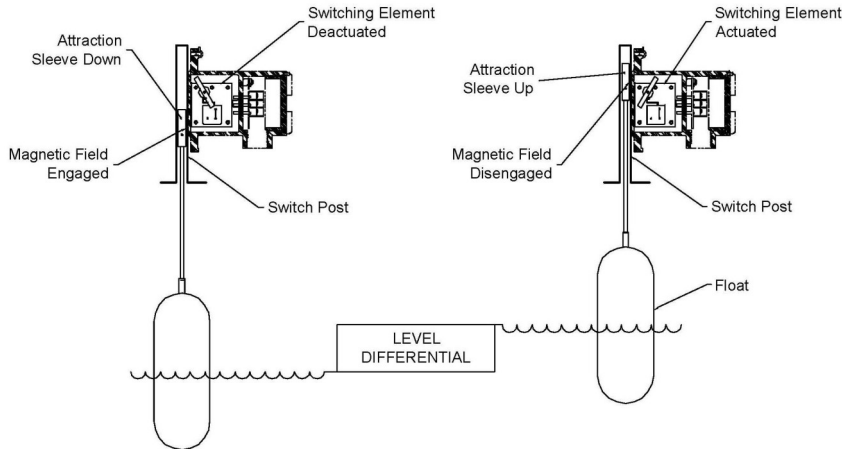

## Displacer Operated Level Switches Model Series 550, 560, 800, 900

Displacer switches offer an alternative means of fluid level measurement different from the traditional float device. While a float follows the liquid level, a displacer remains partially or completely submerged. The buoyancy of the displacer is increased as it becomes covered by more liquid. Therefore, when the displacer weight drops below the spring tension (rising level), the switch mechanism is actuated. Hence, when the displacer weight increases to that greater than the spring tension (falling level), the switch mechanism is de-actuated.

Displacer switches can be utilized in some high pressure and low specific gravity applications where float designs are cost prohibitive or impossible to implement.

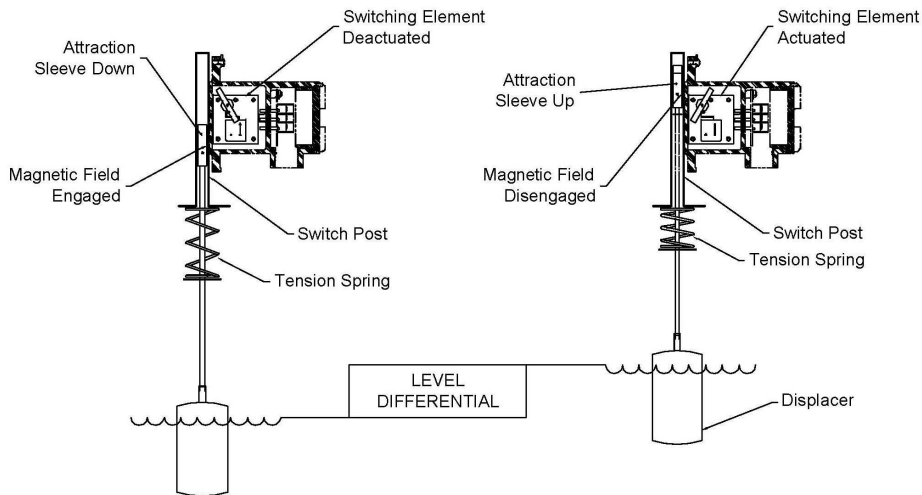



**Model Number Format**

a / b / c / d / e / f  
 LS xxx / xxx / xx / x / x / x

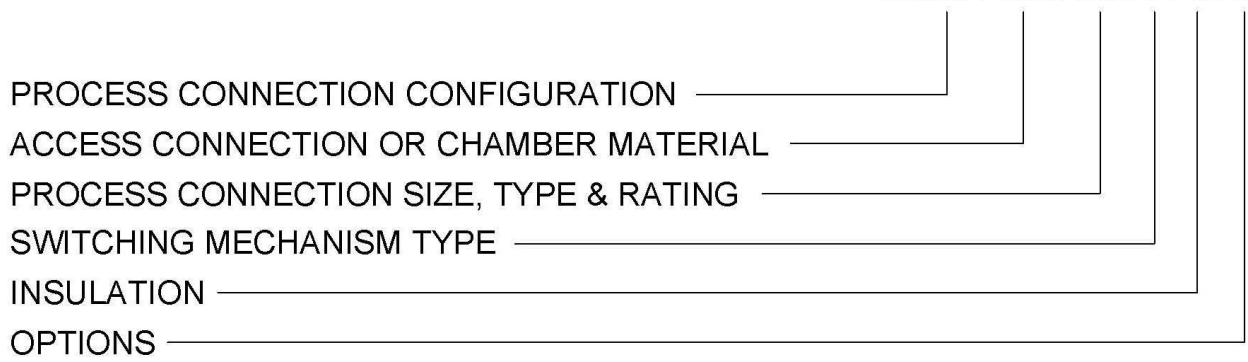

**How to Order:**

- Step 1:**     */a/* Select **Process Connection Configuration**  
 Choose a mechanical level switch model series based on maximum working pressure, maximum temperature and minimum specific gravity.
- Step 2:**     */b/* Select **Access Connection or Chamber Material**
- Step 3:**     */c/* Select **Process Connection Size, Type & Rating**
- Step 4:**     */d/* Select **Switching Mechanism Type**
- Step 5:**     */e/* Select **Insulation**
- Step 6:**     */f/* Select **Options**

# Series LS 500/510

# Model Number Selection: Step 1

## Top Mount Float Series

### Model Number Formats

<b>Series LS 5xx - Top Mounted Float</b>					
<b>50x - Flanged Process Connection</b>			<b>Example Application Data:</b> Pressure 26bar, Temperature 225°C, S.G. .68, 4" Flanged Process Connection, 32 3/8" Pneumatic Switch Point Location		
<b>Example: LS502/CST/SR43/F/IP/SP=32 3/8in.</b>					
Model (Series) (a)	Access Connection Material (b)	Access Connection Size, Type & Rating (c)	Switching Mechanism Type (d)	Insulation (e)	Options (f)
502	CST	SR43	F	IP	SP=32 3/8"

### Step 1:

/a/ Select **PROCESS CONNECTION CONFIGURATION**

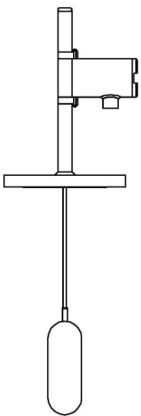

**50x Flanged**

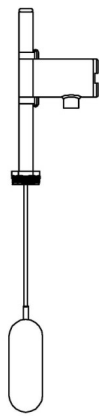

**51x NPT**

Note: For both the 50x and 51x, use the table below to select model series.

## Top Mount Float Series

Model Series	Pressure at Indicated Temperature				Float Mat'l Code	Minimum S.G.
	100° F (psig)	37.7° C (bar)	450° F (psig)	232° C (bar)		
5x1	225	15.5	207	14.3	T2	.4
5x2	500	34.5	460	31.7	S6	.68
5x3	750	51.7	690	47.6	S6	.52

Float Materials: 316 SS (S6) is the standard. The following materials and others are available. Hastelloy C276; Titanium Gr2 and Titanium Gr5. Construction materials are determined by application specifics (i.e. temperature, pressure and specific gravity).

Consult ABB factory for other materials and process conditions not listed.

# Series LS 550/560

# Model Number Selection: Step 1

## Top Mount Displacer Series

### Model Number Formats

<b>Series LS 5xx - Top Mounted Displacer</b>					
<b>56x - Threaded Process Connection</b>		<b>Example Application Data:</b> Pressure: 17 bar, Temperature: 35°C, S.G.: 0.76, 1.5" NPT Process Connection, Switch Point Location 20 3/4"			
<b>Example: LS562/SS6/P15/E/X/SP=20 3/4in.</b>					
Model (Series) (a)	Access Connection Material (b)	Access Connection Size, Type & Rating (c)	Switching Mechanism Type (d)	Insulation (e)	Options (f)
562	SS6	P15	E	X	SP=20 3/4"

### Step 1:

/a/ Select **PROCESS CONNECTION CONFIGURATION**

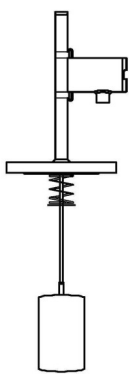

**55x Flanged**



**56x NPT**

Note: For both the 55x and 56x, use the table below to select model series.

### Top Mount Displacer Series

Model Series	Pressure at Indicated Temperature				Displacer Mat'l	Minimum S.G.
	100° F (psig)	37.7° C (bar)	450° F (psig)	232° C (bar)		
5x1	1000	68.9	750	51.7	S6	.6
5x2	275	19.0	182	12.5	S6	.6

Displacer Materials: 316 SS (S6) is the standard. The following materials and others are available. Hastelloy C276; Titanium Gr2, Titanium Gr5 and Porcelain. Construction materials are determined by application specifics (i.e. temperature, pressure and specific gravity).

Consult ABB factory for other materials and process conditions not listed.

**Step 2:**

**/b/ ACCESS CONNECTION MATERIAL**

- CST** CARBON STEEL (STANDARD)
- SS6** 316 SS
- DUP** DUPLEX STAINLESS STEEL
- HSB** HASTELLOY B-3
- HSC** HASTELLOY C-276
- P11** P11 1.25%CHROME, MOLYBDENUM STEEL
- P91** P91 9% CHROME, MOLYBDENUM STEEL
- O** CUSTOM<sup>11</sup>

**Step 3:**

**/c/ ACCESS CONNECTION SIZE TYPE & RATING<sup>1</sup>**

SEE TABLES 3 & 4 (p46-49)  
IN APPENDIX

- O** CUSTOM<sup>10</sup>

**Step 4:**

**/d/ SWITCHING MECHANISM TYPE<sup>2</sup>**

**1 AMP SPDT REED SWITCH**

- A** MS30
- B** MS30EX

**NOTE:** TYPE A & B NOT COMPATIBLE WITH 55X/56X SERIES

**10AMP DPDT CAM ACTION SWITCH**

- C** MS40
- D** MS40/EX
- E** MS41 HERM SEALED (STANDARD)

**PNEUMATIC SWITCH**

- F** PS35
- G** PS45

**Step 5:**

**/e/ INSULATION<sup>3</sup>**

- X** NO INSULATION
- IF** INSULATION FLANGE - RATED UP TO **900°F (482°C) MAX**
- IP** INSULATION PAD - ALL SERVICES  $\geq 180^\circ\text{F}$  (**82°C**) PNEUMATIC SWITCHES ONLY ALL SERVICES  $\geq 300^\circ\text{F}$  (**149°C**) ELECTRIC SWITCHES ONLY
- O** CUSTOM<sup>10</sup>

**Step 6:**

**/f/ OPTIONS**

- X** NO OPTIONS
- IL** INSERTION LENGTH
- CX** CUSTOM CALIBRATION<sup>5</sup>
- SW** STILLING WELL<sup>8</sup>
- ST** SUPPORT TUBE<sup>8</sup>
- IM** INTERFACE LEVEL MEASUREMENT<sup>9</sup>
- O** CUSTOM<sup>10</sup>
- SP** SWITCH POINT LOCATION<sup>6</sup>

**NOTE:** REFERENCE MODEL NUMBER SELECTION NOTES ON THE FOLLOWING PAGE

**NOTES:**

1. See Flange Pressure Rating Table in Appendix. Information in these tables is taken from ASME Standards. DIN, HG, or other International Flange Types require factory consultation.
2. See Switching Mechanisms and Housings on page 38-39. See Switch Mechanism Product Data Sheets for specifications.
3. See Insulation Descriptions on page 40; Insulation Flange (IF) is recommended for personnel safety.
4. Multiple Options: Separate multiple options with semi-colon (;) Example: ...x/B = 2-11/16 in; SW =17".....
5. CX - Custom Calibration: C + "B" or "C" for required dimension (not "B" and "C") and engineering units (mm, in, cm) Example: .... x / CB=2-11/16 in; ..... See "Calibration Dimensions."
6. Customer to specify switch point location to nearest 1/8" or specify CX
7. Only applicable if retrofitting Top Insertion Model into existing Chamber. See Figure 1 below. Customer to specify existing Chamber Length (P) and Chamber ID.
8. See Stilling Well (SW) and Support Tubes (ST) descriptions below in Figure 2 and on page 42.
9. Interface Level Measurement (IM) requires special consideration. Consult factory for details.
10. For options and selections not listed, write requirements after model number. Contact the ABB factory for price and availability.

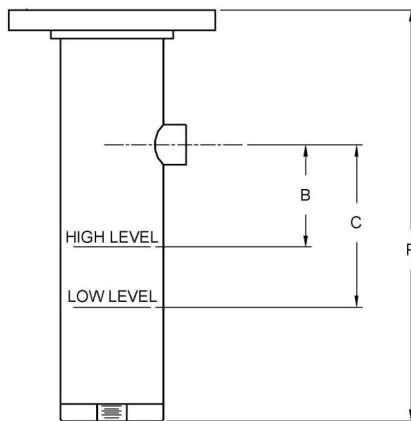

**Figure 1**

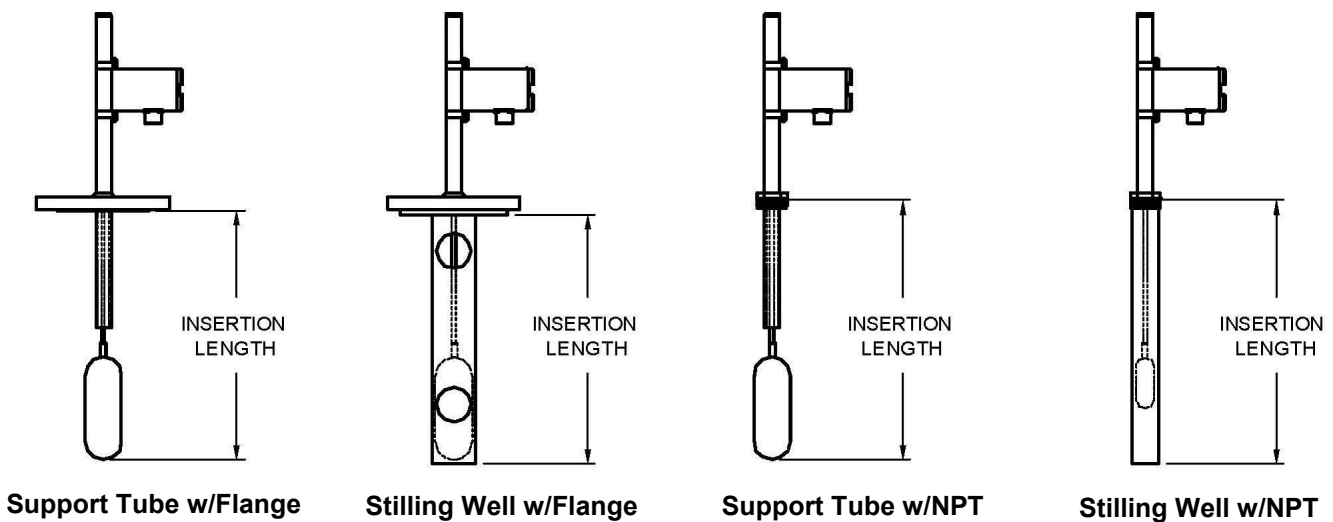

**Figure 2**

## Calibration Dimensions for LS 500/510/550/560 Series

Dimensions in this catalog are for reference only. They may be changed without notice. Contact the factory for certified drawings for a particular model number.

Note: It is important to consider the installation configuration when selecting the process connection. Be sure that the float will fit through the process connection, or that the vessel has access to attach the float from inside the vessel after instrument installation.

500/510 Series (Float)						
Model	Float Size	Minimum Opening Size	Minimum Insertion		Maximum Insertion	
			in	mm	in	mm
5x1	TBD	TBD	4-1/4	108	48	1219
5x2	TBD	TBD	4-1/2	114	48	1219
5x3	TBD	TBD	4-1/4	108	48	1219

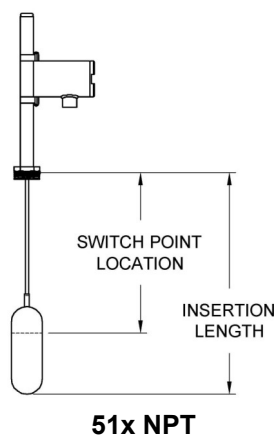
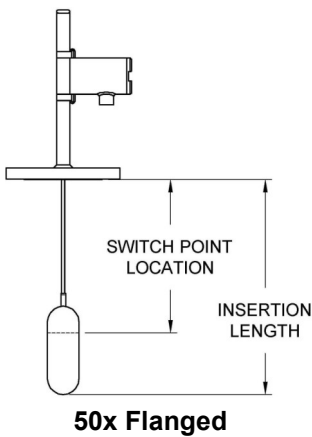

Note: For longer Insertion Length, consult ABB factory.

550/560 Series (Displacer)			
Model	Displacer Size	Maximum Insertion Length	
		in	mm
5x1	TBD	48	1219
5x2	TBD	48	1219

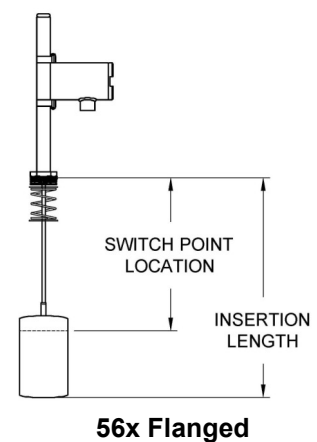
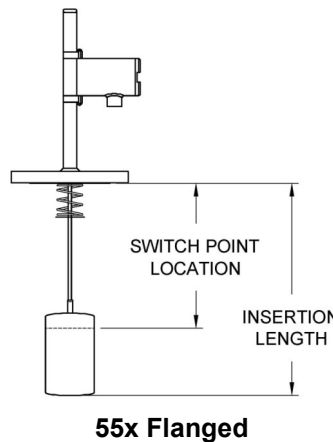

Note: For longer Insertion Length, consult ABB factory.

# Series LS 600

# Model Number Selection: Step 1

## Flanged Chamber Float Series

### Model Number Formats

Series LS 6xx - Flanged Chamber Float					
<b>61x - Side/Side Process Connections</b>			<b>Example Application Data:</b> Pressure 52bar, Temperature 230°C, S.G. 0.61, 2" Flange Process Connection, Pneumatic Output , 3/4" Vent Valve		
<b>Example: LS614/CST/N3F0W9/N74-WR26/F/IH2;IF/VV; C=300mm</b>					
Model (Series) (a)	Chamber Material (b)	Process Connection Size, Type & Rating (c)	Switching Mechanism Type (d)	Insulation (e)	Options (f)
614	CST	N3F0W9/N74-WR26	F	IH2;IF	VV; C=300mm

### Step 1:

/a/ Select **PROCESS CONNECTION CONFIGURATION**

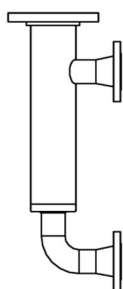

**61x Side/Side**



**62x Side/Side/Drain**

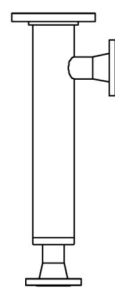

**63x Side/Bottom**

### Carbon Steel Chamber (A106 GrB)

Model Series	Pressure at Indicated Temperature								Float Mat'l Code	Minimum S.G.
	100° F (psig)	37.7° C (bar)	450° F (psig)	232° C (bar)	750° F (psig)	399° C (bar)	1000°F (psig)	538°C (bar)		
6x1	285	19.7	185	12.8	95	6.6	23	1.6	TBD	0.44
6x2	500	34.5	460	31.7	389	26.8	354	24.3	TBD	0.60
6x3	740	51.0	622	42.9	505	34.8	418	28.8	TBD	0.44
6x4	990	68.2	822	56.6	778	53.6	676	46.6	TBD	0.61
6x5	285	19.7	185	12.8	95	6.6	23	1.6	TBD	0.38
6x6	285	19.7	185	12.8	95	6.6	23	1.6	TBD	0.64
6x7	350	24.1	322	22.2	272	18.8	247	17.1	TBD	0.60
6x8	740	51.0	622	42.9	389	26.8	281	19.3	TBD	0.65
6x9	1250	86.2	1150	79.3	TBD	TBD	TBD	TBD	TBD	0.77

Float materials: 316 SS (S6) is the standard. The following materials and others are available. Hastelloy C276; Titanium Gr2 and Titanium Gr5. Construction materials are determined by application specifics (i.e. temperature, pressure and specific gravity).

Consult ABB factory for other chamber materials and process conditions not listed.

### Stainless Steel Chamber (316SS)

Model Series	Pressure at Indicated Temperature								Float Mat'l Code	Minimum S.G.
	100° F (psig)	37.7° C (bar)	450° F (psig)	232° C (bar)	750° F (psig)	399° C (bar)	1000°F (psig)	538°C (bar)		
6x1	275	19.0	182	12.5	95	6.6	27	1.8	TBD	0.44
6x2	500	34.5	460	31.7	389	26.8	354	24.6	TBD	0.60
6x3	720	49.6	497	34.3	425	29.3	287	19.4	TBD	0.44
6x4	1000	68.9	920	63.4	778	53.6	708	48.9	TBD	0.61
6x5	275	19.0	182	12.5	95	6.6	27	1.8	TBD	0.38
6x6	275	19.0	182	12.5	95	6.6	27	1.8	TBD	0.64
6x7	350	24.1	322	22.2	272	18.8	247	16.9	TBD	0.60
6x8	720	49.6	497	34.3	425	29.3	287	19.6	TBD	0.65
6x9	1250	86.2	992	68.4	TBD	TBD	TBD	TBD	TBD	0.77

# Series LS 600

# Model Number Selection: Steps 2 - 6

## Step 2:

### /b/ CHAMBER MATERIAL

<b>CST</b>	CARBON STEEL (STANDARD)
<b>SS6</b>	316 SS
<b>DUP</b>	DUPLEX STAINLESS STEEL
<b>HSB</b>	HASTELLOY B-3
<b>HSC</b>	HASTELLOY C-276
<b>P11</b>	P11 1.25%CHROME, MOLYBDENUM STEEL
<b>P91</b>	P91 9% CHROME, MOLYBDENUM STEEL
<b>O</b>	CUSTOM <sup>11</sup>

## Step 3:

### /c/ PROCESS CONNECTION SIZE TYPE & RATING<sup>1,9, 10</sup>

SEE TABLES 3 & 4 (p46-49)  
IN APPENDIX

**O** CUSTOM<sup>12</sup>

## Step 4:<sup>4</sup>

### /d/ SWITCHING MECHANISM TYPE<sup>2</sup>

#### 1 AMP SPDT REED SWITCH

**A** MS30  
**B** MS30EX

#### 10AMP DPDT CAM ACTION SWITCH

**C** MS40  
**D** MS40/EX  
**E** MS41 HERM SEALED  
(STANDARD)

#### PNEUMATIC SWITCH

**F** PS35  
**G** PS45

## Step 5:<sup>4</sup>

### /e/ INSULATION<sup>3</sup>

<b>X</b>	NO INSULATION
<b>IP</b>	INSULATION PAD - ALL SERVICES $\geq 180^{\circ}\text{F}$ ( $82^{\circ}\text{C}$ ) PNEUMATIC SWITCHES ONLY
<b>IH1</b>	ELECTRIC SWITCHES ONLY HIGH TEMP. INSULATION; FLOAT CHAMBER ONLY; 1/2"THICK, $250^{\circ}\text{F}$ ( $121^{\circ}\text{C}$ ) <b>MAX</b>
<b>IH1D</b>	HIGH TEMP. INSULATION; FLOAT CHAMBER & VENT/ DRAIN FLANGES; 1/2"THICK, $250^{\circ}\text{F}$ ( $121^{\circ}\text{C}$ ) <b>MAX</b>
<b>IH2</b>	HIGH TEMP. INSULATION; FLOAT CHAMBER ONLY; 1"THICK, $500^{\circ}\text{F}$ ( $260^{\circ}\text{C}$ ) <b>MAX</b>
<b>IH2D</b>	HIGH TEMP. INSULATION; FLOAT CHAMBER & VENT/ DRAIN FLANGES; 1"THICK, $500^{\circ}\text{F}$ ( $260^{\circ}\text{C}$ ) <b>MAX</b>
<b>IH3</b>	HIGH TEMP. INSULATION; FLOAT CHAMBER ONLY; 2"THICK, $900^{\circ}\text{F}$ ( $482^{\circ}\text{C}$ ) <b>MAX</b>
<b>IH3D</b>	HIGH TEMP. INSULATION; FLOAT CHAMBER & VENT/ DRAIN FLANGES; 2"THICK, $900^{\circ}\text{F}$ ( $482^{\circ}\text{C}$ ) <b>MAX</b>
<b>IF</b>	INSULATION FLANGE - RATED UP TO $900^{\circ}\text{F}$ ( $482^{\circ}\text{C}$ ) <b>MAX</b>
<b>IL1</b>	CRYOGENIC INSULATION; 2"THICK; SINGLE LAYER; $-100^{\circ}\text{F}$ ( $-73^{\circ}\text{C}$ ) <b>MINIMUM</b>
<b>IL2</b>	CRYOGENIC INSULATION; 3" THICK; DOUBLE LAYER; $-200^{\circ}\text{F}$ ( $-129^{\circ}\text{C}$ ) <b>MINIMUM</b>
<b>IL3</b>	CRYOGENIC INSULATION; 4" THICK; DOUBLE LAYER; $-320^{\circ}\text{F}$ ( $-196^{\circ}\text{C}$ ) <b>MINIMUM</b>
<b>O</b>	CUSTOM <sup>12</sup>

## Step 6:<sup>4</sup>

### /h/ OPTIONS

<b>X</b>	NO OPTIONS
<b>CX</b>	CUSTOM CALIBRATION <sup>5</sup>
<b>LX</b>	CUSTOM CHAMBER LENGTH <sup>6</sup>
<b>VV</b>	VENT VALVE <sup>7</sup>
<b>DV</b>	DRAIN VALVE <sup>7</sup>
<b>IV</b>	ISOLATION VALVE <sup>7</sup>
<b>IM</b>	INTERFACE LEVEL MEASUREMENT <sup>8</sup>
<b>TT1</b>	STEAM TRACE TUBING
<b>ET1xx</b>	ELECTRIC TRACING; CLASS 1, DIV 2, GP BCD; $221^{\circ}\text{F}$ ( $105^{\circ}\text{C}$ ) <b>MAX</b> , FIXED SET POINT CONTROL <sup>11</sup>
<b>ET2x</b>	ELECTRIC TRACING; CLASS 1, DIV 2, GP BCD; $400^{\circ}\text{F}$ ( $204^{\circ}\text{C}$ ) <b>MAX</b> , ADJUSTABLE SETPOINT CONTROL <sup>11</sup>
<b>ET3x</b>	ELECTRIC TRACING; CLASS 1, DIV 2, GP BCD; $800^{\circ}\text{F}$ ( $427^{\circ}\text{C}$ ) <b>MAX</b> , ADJUSTABLE SETPOINT CONTROL <sup>11</sup>
<b>G</b>	GUSSETS ON PROCESS CONNECTION (HIGH VIBRATION APPLICATIONS)
<b>O</b>	CUSTOM <sup>12</sup>

**NOTE:** REFERENCE MODEL NUMBER  
SELECTION NOTES ON THE  
FOLLOWING PAGE



**NOTES:**

1. See Flange Pressure Rating Table in Appendix. Information in these tables is taken from ASME Standards. DIN, HG, or other International Flange Types require factory consultation.
2. See Switching Mechanisms and Housings on page 38-39. See Switch Mechanism Product Data Sheets for specifications.
3. See Insulation Descriptions on page 40; Insulation Jackets (IH) & Insulation Flange Covers are recommended for personnel safety.
4. Multiple Options: Separate multiple options with semi-colon (;) Example: ...x/B = 2-11/16 in; H = 287mm; .....
5. CX - Custom Calibration: C + "B" or "C" for required dimension (not "B" and "C") and engineering units (mm, in, cm) Example: .... x / CB=2-11/16 in; ..... See "Calibration Dimensions."
6. LX - Custom Length: L + "D" or "H" for required dimension (not "D" and "H") and engineering units (mm, in, cm) Example: .... x / LH = 287mm; ..... See "Dimension Tables."
7. See Valve Description on Page 41. Vent Valve (VV), Drain Valve (DV), Isolation Valves (IV) Customer to specify valve type and size.
8. Interface Level Measurement (IM) requires special consideration. Consult factory for details.
9. For Available Process Connections, see Tables 3 and 4 (p46-49) in Appendix.
10. Chamber Access Flange Types will be the same as Process Connections. If Process Connections are not flanges, Raised Face Slip-ons will be the standard (unless otherwise specified). Use option "O" if flange type differs from process connection.
11. Specify power supply 1) 110, 2) 220, 3) 277 OR 4) 440 VAC) (ex. ET21= ET2 with 110VAC power supply). For ET1xx series only, specify setpoint A) 35°, B) 45°, C) 60°, D) 90° or E) 185°F (1.7°, 7.2°, 15.6°, 32.2°, or 85°C) (ex. ET11A = ET1 with 110VAC power supply and a setpoint of 35°F)
12. For options and selections not listed, write requirements after model number. Contact the ABB factory for price and availability.

**Calibration Dimensions for LS 600 series**

1. "B" is the distance that the switch trips on rising level at the specified S.G.
2. "C" is the distance that the switch resets on falling level at the specified S.G.
3. The "B" dimension is the default switch calibration setting.
4. The "C" dimension will vary depending on the particular switch unit specified.
5. If a different "B" or the "C" dimension is required, it should be stated as shown under Options.
6. Calibration accuracy is +/- 1/4" (6mm)

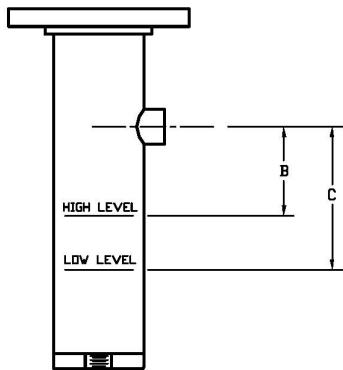

600 Series 6x1		
S.G.	"B"	"C"
.54	2-11/16"	3-3/4"
.60	3-3/16"	4-1/8"
.70	3-3/4"	4-9/16"
.80	4-3/16"	4-7/8"
.90	4-9/16"	5-1/8"
1.0	4-13/16"	5-3/8"

600 Series 6x2		
S.G.	"B"	"C"
.64	2-9/16"	3-1/2"
.70	3"	3-3/4"
.80	3-1/2"	4-3/16"
.90	3-15/16"	4-1/2"
1.0	4-1/4"	4-3/4"
1.1	4-1/2"	5"

600 Series 6x3		
S.G.	"B"	"C"
.50	2-9/16"	3-3/8"
.60	3-5/8"	4-1/16"
.70	4-1/8"	4-7/16"
.80	4-7/16"	4-3/4"
.90	4-11/16"	4-15/16"
1.1	4-7/8"	5-1/8"

600 Series 6x4		
S.G.	"B"	"C"
.61	2-1/2"	3-1/4"
.70	3-7/16"	3-13/16"
.80	3-7/8"	4-3/16"
.90	4-1/4"	4-1/2"
1.0	4-1/2"	4-11/16"
1.1	4-11/16"	4-7/8"

600 Series 6x5		
S.G.	"B"	"C"
.38	3-1/4"	4-1/16"
.40	3-13/16"	4-3/8"
.50	5-1/16"	5-5/16"
.60	5-11/16"	5-7/8"
.70	6-1/16"	6-1/4"
.80	6-3/8"	6-9/16"

600 Series 6x6; 6x7		
S.G.	"B"	"C"
.65	2-1/16"	3-7/16"
.70	2-3/8"	3-5/8"
.80	2-3/4"	3-7/8"
.90	3-1/8"	4-1/16"
1.0	3-3/8"	4-1/4"
1.1	3-9/16"	4-3/8"

600 Series 6x8; 6x9		
S.G.	"B"	"C"
.93	2-5/8"	3-1/2"
1.0	3"	3-3/4"
1.1	3-7/16"	4-1/16"
1.2	3-3/4"	4-3/8"
1.3	4"	4-9/16"
1.4	4-1/4"	4-13/16"

## Chamber Dimensions for LS 600 series

- See Tables on page 19 for dimensions for selected process connection size.
- Drawings not to scale.

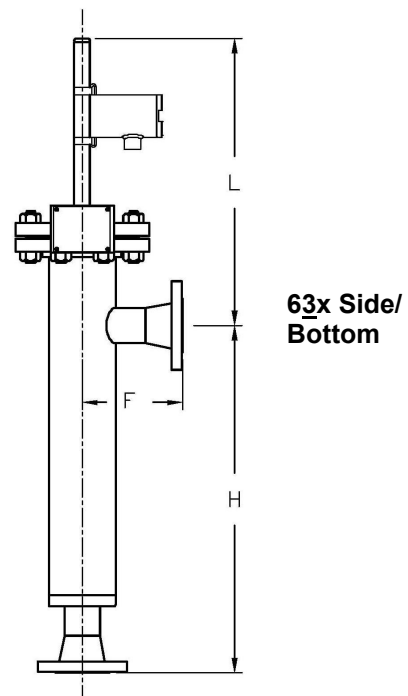
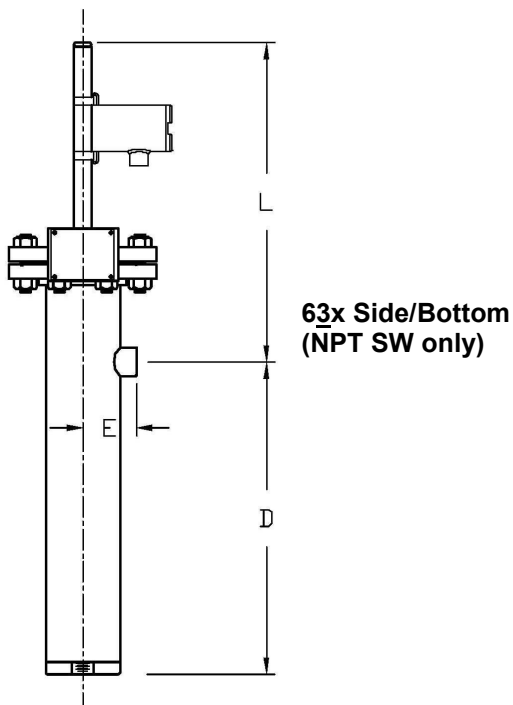
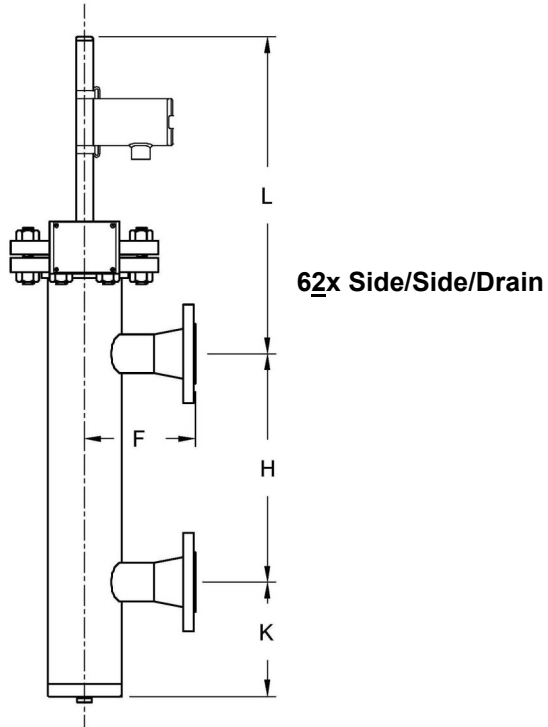
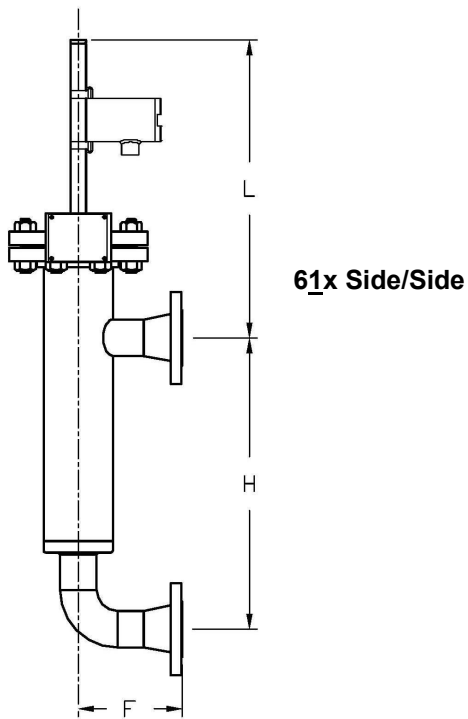

**Dimension Tables**

**1" Process Connection Dimension Table**

	D*		E*		F		H		K		L	
	Inches	mm	Inches	mm	inches	mm	inches	mm	inches	mm	inches	mm
6x1	10-1/2	267	3-11/16	94	TBD	TBD	14	356	TBD	TBD	TBD	TBD
6x2												
6x3	10-3/8	264	4-3/4	121	TBD	TBD	14	356	TBD	TBD	TBD	TBD
6x4												
6x5	12-5/8	321	5-3/4	146	TBD	TBD	16	406	TBD	TBD	TBD	TBD
6x6	9	229	3-3/16	81	TBD	TBD	14	356	TBD	TBD	TBD	TBD
6x7												
6x8	10-1/2	267	3-11/16	94	TBD	TBD	14	356	TBD	TBD	TBD	TBD

\* These dimensions apply to Model 63x Side/Bottom with Threaded or Socket "Flange Type" only (see p18)

**1-1/2" Process Connection Dimension Table**

	D*		E*		F		H		K		L	
	Inches	mm	Inches	mm	inches	mm	inches	mm	inches	mm	inches	mm
6x1	10-9/16	268	3-3/4	95	TBD	TBD	14	356	TBD	TBD	TBD	TBD
6x2												
6x3	10-7/16	265	4-13/16	122	TBD	TBD	14	356	TBD	TBD	TBD	TBD
6x4												
6x5	12-11/16	322	5-13/16	148	TBD	TBD	16	406	TBD	TBD	TBD	TBD
6x6	9	229	3-1/4	83	TBD	TBD	14	356	TBD	TBD	TBD	TBD
6x7												
6x8	10-9/16	268	3-3/4	95	TBD	TBD	14	356	TBD	TBD	TBD	TBD

\* These dimensions apply to Model 63x Side/Bottom with Threaded or Socket "Flange Type" only (see p18)

**2" Process Connection Dimension Table**

	D*		E*		F		H		K		L	
	Inches	mm	Inches	mm	inches	mm	inches	mm	inches	mm	inches	mm
6x1	10-11/16	271	3-7/8	98	TBD	TBD	14	356	TBD	TBD	TBD	TBD
6x2												
6x3	10-9/16	268	4-15/16	125	TBD	TBD	14	356	TBD	TBD	TBD	TBD
6x4												
6x5	12-13/16	325	5-15/16	151	TBD	TBD	16	406	TBD	TBD	TBD	TBD
6x6	-- NA--	-- NA--	--NA--	-- NA--	TBD	TBD	14	356	TBD	TBD	TBD	TBD
6x7												
6x8	10-11/16	271	3-7/8	98	TBD	TBD	14	356	TBD	TBD	TBD	TBD

\* These dimensions apply to Model 63x Side/Bottom with Threaded or Socket "Flange Type" only (see p18)

# Series LS 700

# Model Number Selection: Step 1

## Sealed Chamber Float Series

### Model Number Format

<b>Series LS 7xx - Sealed Chamber Float</b>					
<b>Series LS 73x - Side/Bottom Process Connections</b>			<b>Example Application Data:</b> Pressure 27bar, Temperature 35°C, S.G. 0.5, 1" Process Connection		
<b>Example:LS738/SS6/C1W3/SC13/B/X/LH=315mm</b>					
Model (Series) (a)	Chamber Material (b)	Process Connection Size, Type & Rating (c)	Switching Mechanism Type (d)	Insulation (e)	Options (f)
738	SS6	C1W3/SC13	B	X	LH=315mm

### Step 1:

/a/ Select **PROCESS CONNECTION CONFIGURATION**



**71x Side/Side**

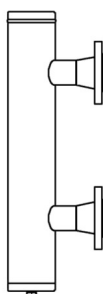

**72x Side/Side/Drain**

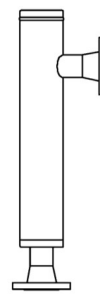

**73x Side/Bottom**

### Carbon Steel Chamber (A106 GrB)

Model Series	Pressure at Indicated Temperature								Float Mat'l Code	Minimum S.G.
	100° F (psig)	37.7° C (bar)	450° F (psig)	232° C (bar)	750° F (psig)	399° C (bar)	1000°F (psig)	538°C (bar)		
7x1	225	15.5	207	14.3	175	12.1	159	11.0	TBD	.37
7x2	300	20.7	276	19.0	233	16.1	212	14.6	TBD	.54
7x3	500	34.5	460	31.7	389	26.8	354	24.4	TBD	.64
7x4	1250	86.2	1150	79.3	972	67.0	884	60.9	TBD	.93
7x5	750	51.7	690	47.6	584	40.3	531	36.6	TBD	.5
7x6	1000	68.9	920	63.4	778	53.6	708	48.8	TBD	.63
7x7	1000	68.9	920	63.4	778	53.6	708	48.8	TBD	.61
7x8	450	31.0	414	28.5	350	24.1	318	21.9	TBD	.38
7x9	350	24.1	322	22.2	272	18.8	247	17.1	TBD	.65

Float materials: 316 SS (S6) is the standard. The following materials and others are available. Hastelloy C276; Titanium Gr2 and Titanium Gr5. Construction materials are determined by application specifics (i.e. temperature, pressure and specific gravity).

### Stainless Steel Chamber (316SS)

Model Series	Pressure at Indicated Temperature								Float Mat'l Code	Minimum S.G.
	100° F (psig)	37.7° C (bar)	450° F (psig)	232° C (bar)	750° F (psig)	399° C (bar)	1000°F (psig)	538°C (bar)		
7x1	225	15.5	207	14.3	175	12.1	159	11.0	TBD	.37
7x2	300	20.7	276	19.0	233	16.1	212	14.6	TBD	.54
7x3	500	34.5	460	31.7	389	26.8	354	24.4	TBD	.64
7x4	1250	86.2	1052	72.5	972	67.0	847	58.4	TBD	.93
7x5	750	51.7	690	47.6	584	40.3	531	36.6	TBD	.5
7x6	1000	68.9	838	57.8	778	53.6	677	46.6	TBD	.63
7x7	1000	68.9	838	57.8	778	53.6	677	46.6	TBD	.61
7x8	450	31.0	414	28.5	350	24.1	318	21.9	TBD	.38
7x9	350	24.1	322	22.2	272	18.8	247	17.1	TBD	.65

Consult ABB factory for other chamber materials and process conditions not listed.

# Series LS 700

# Model Number Selection: Steps 2 - 6

## Step 2:

### /b/ CHAMBER MATERIAL

- CST** CARBON STEEL (STANDARD)
- SS6** 316 SS
- DUP** DUPLEX STAINLESS STEEL
- HSB** HASTELLOY B-3
- HSC** HASTELLOY C-276
- P11** P11 1.25%CHROME, MOLYBDENUM STEEL
- P91** P91 9% CHROME, MOLYBDENUM STEEL
- O** CUSTOM<sup>11</sup>

## Step 3:

### /c/ PROCESS CONNECTION SIZE TYPE & RATING<sup>1,9</sup>

SEE TABLES 3 & 4 (p46-49) IN APPENDIX

- O** CUSTOM<sup>11</sup>

## Step 4:<sup>4</sup>

### /d/ SWITCHING MECHANISM TYPE<sup>2</sup>

- 1 AMP SPDT REED SWITCH**
- A MS30**
- B MS30EX**
- 10AMP DPDT CAM ACTION SWITCH**
- C MS40**
- D MS40/EX**
- E MS41 HERM SEALED (STANDARD)**
- PNEUMATIC SWITCH**
- F PS35**
- G PS45**

## Step 5:<sup>4</sup>

### /e/ INSULATION<sup>3</sup>

- X** NO INSULATION
- IP** INSULATION PAD - ALL SERVICES  $\geq 180^{\circ}\text{F}$  ( $82^{\circ}\text{C}$ ) PNEUMATIC SWITCHES ONLY ALL SERVICES  $\geq 300^{\circ}\text{F}$  ( $149^{\circ}\text{C}$ ) ELECTRIC SWITCHES ONLY
- IH1** HIGH TEMP. INSULATION; FLOAT CHAMBER ONLY; 1/2"THICK, **250°F (121°C) MAX**
- IH1D** HIGH TEMP. INSULATION; FLOAT CHAMBER & VENT/ DRAIN FLANGES; 1/2"THICK, **250°F (121°C) MAX**
- IH2** HIGH TEMP. INSULATION; FLOAT CHAMBER ONLY; 1"THICK, **500°F (260°C) MAX**
- IH2D** HIGH TEMP. INSULATION; FLOAT CHAMBER & VENT/ DRAIN FLANGES; 1"THICK, **500°F (260°C) MAX**
- IH3** HIGH TEMP. INSULATION; FLOAT CHAMBER ONLY; 2"THICK, **900°F (482°C) MAX**
- IH3D** HIGH TEMP. INSULATION; FLOAT CHAMBER & VENT/ DRAIN FLANGES; 2"THICK, **900°F (482°C) MAX**
- IL1** CRYOGENIC INSULATION; 2"THICK; SINGLE LAYER; **-100°F (-73°C) MINIMUM**
- IL2** CRYOGENIC INSULATION; 3" THICK; DOUBLE LAYER; **-200°F (-129°C) MINIMUM**
- IL3** CRYOGENIC INSULATION; 4" THICK; DOUBLE LAYER; **-320°F (-196°C) MINIMUM**
- O** CUSTOM<sup>11</sup>

## Step 6:<sup>4</sup>

### /h/ OPTIONS

- X** NO OPTIONS
- CX** CUSTOM CALIBRATION<sup>5</sup>
- LX** CUSTOM CHAMBER LENGTH<sup>6</sup>
- VV** VENT VALVE<sup>7</sup>
- DV** DRAIN VALVE<sup>7</sup>
- IV** ISOLATION VALVE<sup>7</sup>
- IM** INTERFACE LEVEL MEASUREMENT<sup>8</sup>
- TT1** STEAM TRACE TUBING
- ET1xx** ELECTRIC TRACING; CLASS 1, DIV 2, GP BCD; **221°F(105°C) MAX**, FIXED SET POINT CONTROL<sup>10</sup>
- ET2x** ELECTRIC TRACING; CLASS 1, DIV 2, GP BCD; **400°F(204°C) MAX**, ADJUSTABLE SETPOINT CONTROL<sup>10</sup>
- ET3x** ELECTRIC TRACING; CLASS 1, DIV 2, GP BCD; **800°F (427°C) MAX**, ADJUSTABLE SETPOINT CONTROL<sup>10</sup>
- G** GUSSETS ON PROCESS CONNECTION (HIGH VIBRATION APPLICATIONS)
- O** CUSTOM<sup>11</sup>

**NOTE:** REFERENCE MODEL NUMBER SELECTION NOTES ON THE FOLLOWING PAGE

## NOTES:

1. See Flange Pressure Rating Table in Appendix. Information in these tables is taken from ASME Standards. DIN, HG, or other International Flange Types require factory consultation.
2. See Switching Mechanisms and Housings on page 38-39. See Switch Mechanism Product Data Sheets for specifications.
3. See Insulation Descriptions on page 40; Insulation Jackets (IH) & Insulation Flange Covers (IF) are recommended for personnel safety.
4. Multiple Options: Separate multiple options with semi-colon (;) Example: ...x/B = 2-11/16 in; H = 287mm; .....
5. CX - Custom Calibration: C + "B" or "C" for required dimension (not "B" and "C") and engineering units (mm, in, cm) Example: .... x / CB=2-11/16 in; ..... See "Calibration Dimensions."
6. LX - Custom Length: L + "D" or "H" for required dimension (not "D" and "H") and engineering units (mm, in, cm) Example: .... x / LH = 287mm; ..... See "Dimension Tables."
7. See Valve Description on Page 41. Vent Valve (VV), Drain Valve (DV), Isolation Valves (IV) Customer to specify valve type and size.
8. Interface Level Measurement (IM) requires special consideration. Consult factory for details.
9. For Available Process Connections, see Tables 3 and 4 (p46-49) in Appendix.
10. Specify power supply 1) 110, 2) 220, 3) 277 & 4) 440 VAC (ex. ET21= ET2 with 110VAC power supply). For ET1xx series only, specify setpoint A) 35°, B) 45°, C) 60°, D) 90° or E) 185°F (1.7°, 7.2°, 15.6°, 32.2°, or 85°C) (ex. ET11A = ET1 with 110VAC power supply and a setpoint of 35°F)
11. For options and selections not listed, write requirements after model number. Contact the ABB factory for price and availability.

## Calibration Dimensions for LS 700 series

1. "B" is the distance that the switch trips on rising level at the specified S.G.
2. "C" is the distance that the switch resets on falling level at the specified S.G.
3. The "B" dimension is the default switch calibration setting.
4. The "C" dimension will vary depending on the particular switch unit specified.
5. If a different "B" or the "C" dimension is required, it should be stated as shown under Options.
6. Calibration accuracy is +/- 1/4" (6mm)

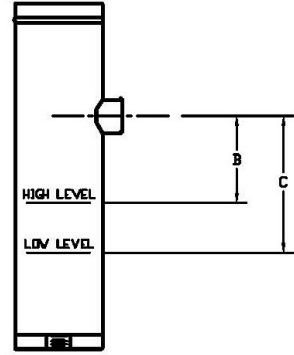

700 Series 7x1		
S.G.	"B"	"C"
0.37	2-5/16"	3-1/2"
0.40	3"	3-3/4"
0.50	3-15/16"	4-3/8"
0.60	4-3/8"	4-3/4"
0.70	4-3/4"	5-1/16"
0.80	4-15/16"	5-1/4"

700 Series 7x2		
S.G.	"B"	"C"
0.54	2-11/16"	3-3/4"
0.60	3-3/16"	4-1/8"
0.70	3-3/4"	4-9/16"
0.80	4-3/16"	4-7/8"
0.90	4-9/16"	5-1/8"
1.0	4-13/16"	5-3/8"

700 Series 7x3		
S.G.	"B"	"C"
0.64	2-9/16"	3-1/2"
0.70	3"	3-3/4"
0.80	3-1/2"	4-13/16"
0.90	3-15/16"	4-1/2"
1.0	4-1/4"	4-3/4"
1.1	4-1/2"	5"

700 Series 7x4		
S.G.	"B"	"C"
0.93	2-5/8"	3-1/2"
1.0	3"	3-3/4"
1.1	3-7/16"	4-1/16"
1.2	3-3/4"	4-3/8"
1.3	4"	4-9/16"
1.4	4-1/4"	4-13/16"

700 Series 7x5		
S.G.	"B"	"C"
0.50	2-9/16"	3-3/8"
0.60	3-5/8"	4-1/16"
0.70	4-1/8"	4-7/16"
0.80	4-7/16"	4-3/4"
0.90	4-11/16"	4-15/16"
1.0	4-7/8"	5-1/8"

700 Series 7x6		
S.G.	"B"	"C"
0.63	2-5/8"	3-3/4"
0.70	3-7/16"	4-1/16"
0.80	3-7/8"	4-3/8"
0.90	4-3/16"	4-9/16"
1.0	4-7/16"	4-3/4"
1.1	4-5/8"	4-7/8"

700 Series 7x7		
S.G.	"B"	"C"
0.61	2-1/2"	3-1/4"
0.7	3-7/16"	3-13/16"
0.8	3-15/16"	4-3/16"
0.9	4-1/4"	4-1/2"
1.0	4-1/2"	4-3/4"
1.1	4-11/16"	4-7/8"

700 Series 7x8		
S.G.	"B"	"C"
0.38	3-1/4"	4-1/16"
0.40	3-13/16"	4-3/8"
0.50	5-1/16"	5-5/16"
0.60	5-11/16"	5-7/8"
0.70	6-1/16"	6-1/4"
0.80	6-3/8"	6-9/16"

700 Series 7x9		
S.G.	"B"	"C"
0.65	2-1/16"	3-7/16"
0.70	2-3/8"	3-5/8"
0.80	2-3/4"	3-7/8"
0.90	3-1/8"	4-1/16"
1.0	3-3/8"	4-1/4"
1.1	3-9/16"	4-3/8"



## Chamber Dimensions for LS 700 series

- See Tables on page 25 for dimensions for selected process connection size.
- Drawings not to scale.

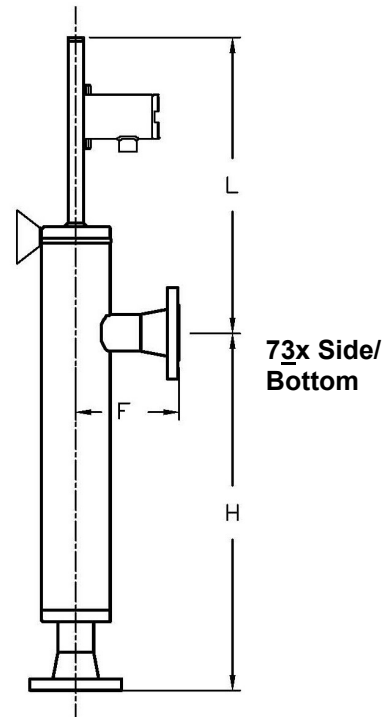
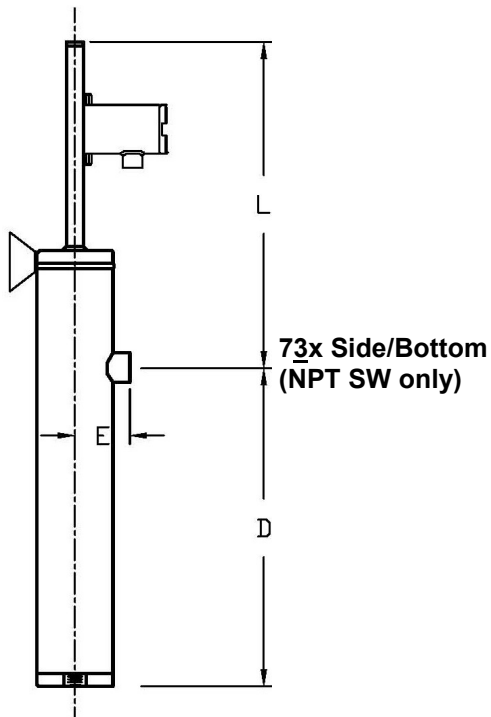
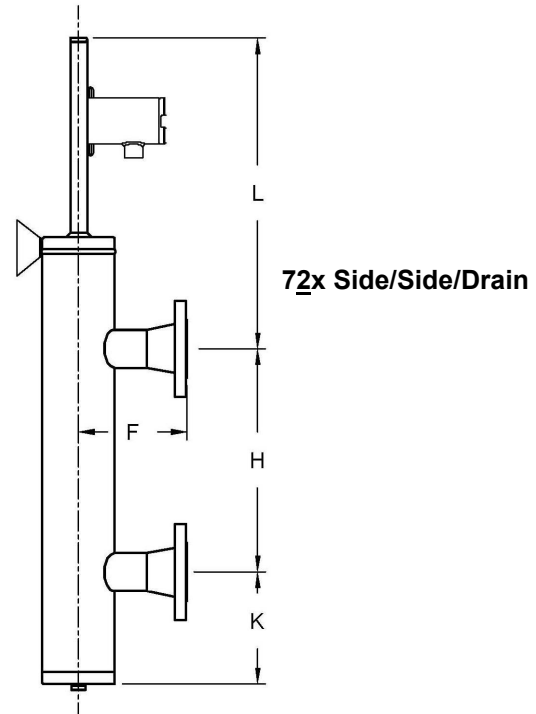
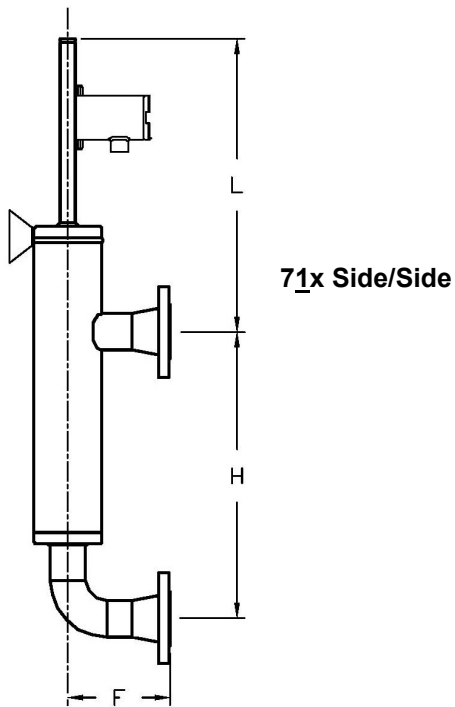

**Dimension Tables**

**1" Process Connection Dimension Table**

	D*		E*		F		H		K		L	
	inches	mm	inches	mm	inches	mm	inches	mm	inches	mm	inches	mm
7x1	10-3/8	264	4-3/4	121	TBD	TBD	14	356	TBD	TBD	TBD	TBD
7x2	10-1/2	267	3-11/16	94	TBD	TBD	14	356	TBD	TBD	TBD	TBD
7x3												
7x4												
7x5	10-3/8	264	4-3/4	121	TBD	TBD	14	356	TBD	TBD	TBD	TBD
7x6												
7x7												
7x8	12-5/8	321	5-3/4	146	TBD	TBD	16	406	TBD	TBD	TBD	TBD
7x9	9	229	3-3/16	81	TBD	TBD	14	356	TBD	TBD	TBD	TBD

\* These dimensions apply to Model 63x Side/Bottom with Threaded or Socket "Flange Type" only (see p.24)

**1-1/2" Process Connection Dimension Table**

	D*		E*		F		H		K		L	
	inches	mm	inches	mm	inches	mm	inches	mm	inches	mm	inches	mm
7x1	10-7/16	265	4-13-16	122	TBD	TBD	14	356	TBD	TBD	TBD	TBD
7x2												
7x3	10-9/16	268	3-3/4	95	TBD	TBD	14	356	TBD	TBD	TBD	TBD
7x4												
7x5	10-7/16	265	4-13/16	122	TBD	TBD	14	356	TBD	TBD	TBD	TBD
7x6	10-7/16	265	4-13/16	122	TBD	TBD	14	356	TBD	TBD	TBD	TBD
7x7												
7x8	12-11/16	322	5-13/16	147	TBD	TBD	16	406	TBD	TBD	TBD	TBD

\* These dimensions apply to Model 63x Side/Bottom with Threaded or Socket "Flange Type" only (see p.24)

**2" Process Connection Dimension Table**

	D*		E*		F		H		K		L	
	inches	mm	inches	mm	inches	mm	inches	mm	inches	mm	inches	mm
7x1	10-9/16	269	4-15/16	126	TBD	TBD	14	356	TBD	TBD	TBD	TBD
7x2												
7x3	10-11/16	273	3-7/8	99	TBD	TBD	14	356	TBD	TBD	TBD	TBD
7x4												
7x5	10-9/16	269	4-15/16	126	TBD	TBD	14	356	TBD	TBD	TBD	TBD
7x6	10-9/16	269	4-15/16	126	TBD	TBD	14	356	TBD	TBD	TBD	TBD
7x7												
7x8	12-13/16	326	5-15/16	151	TBD	TBD	16	406	TBD	TBD	TBD	TBD

\* These dimensions apply to Model 63x Side/Bottom with Threaded or Socket "Flange Type" only (see p.24)

# Series LS 800

# Model Number Selection: Step 1

## Flanged Chamber Displacer Series

### Model Number Formats

Series LS 8xx - Flanged Chamber Displacer					
82x - Side / Side/ Drain Process Connections			Example Application Data: Pressure 150bar, Temperature 35°C, S.G. 0.5, 3" Flange Process Connection		
Example: LS824/SS6/GEGE/SJ315/D/IH2D/CB=2-11/16"					
Model (Series) (a)	Chamber Material (b)	Process Connection Size, Type & Rating (c)	Switching Mechanism Type (d)	Insulation (e)	Options (f)
824	SS6	GEGE/SJ315	D	IH2D	CB=2-11/16"

### Step 1:

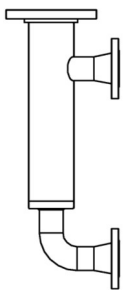

81x Side/Side



82x Side/Side/Drain

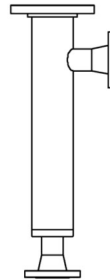

83x Side/Bottom

### Carbon Steel Chamber (A106 GrB)

Model Series	Pressure at Indicated Temperature				Float Mat'l Code	Minimum S.G.
	100° F (psig)	37.7° C (bar)	450° F (psig)	232° C (bar)		
8x1	285	19.7	185	12.8	S6	.4
8x2	740	51.0	618	42.6	S6	.4
8x3	1480	102.0	1235	85.2	S6	.4
8x4	3376	232.8	3083	212.6	S6	.4

Standard displacer units are not available above 450°F (232°C)

### Stainless Steel Chamber (316SS)

Model Series	Pressure at Indicated Temperature				Float Mat'l Code	Minimum S.G.
	100° F (psig)	37.7° C (bar)	450° F (psig)	232° C (bar)		
8x1	275	19.0	182	12.5	S6	.4
8x2	720	49.6	497	34.3	S6	.4
8x3	1440	99.3	992	68.4	S6	.4
8x4	3600	248.2	2480	171.0	S6	.4

Standard displacer units are not available above 450°F (232°C)

Displacer Materials: 316 SS (S6) is the standard. The following materials and others are available. Hastelloy C276; Titanium Gr2, Titanium Gr5 and Porcelain. Construction materials are determined by application specifics (i.e. temperature, pressure and specific gravity).

Consult ABB factory for other chamber materials and process conditions not listed.

**Step 2:**

**/b/ CHAMBER MATERIAL**

- CST** CARBON STEEL (STANDARD)
- SS6** 316 SS
- DUP** DUPLEX STAINLESS STEEL
- HSB** HASTELLOY B-3
- HSC** HASTELLOY C-276
- P11** P11 1.25%CHROME, MOLYBDENUM STEEL
- P91** P91 9% CHROME, MOLYBDENUM STEEL
- O** CUSTOM<sup>11</sup>

**Step 3:**

**/c/ PROCESS CONNECTION SIZE TYPE & RATING<sup>1,9, 10</sup>**

SEE TABLES 3 & 4 (p46-49) IN APPENDIX

- O** CUSTOM<sup>12</sup>

**Step 4:<sup>4</sup>**

**/d/ SWITCHING MECHANISM TYPE<sup>2</sup>**

**10 AMP DPDT CAM ACTION SWITCH**

- C** MS40
- D** MS40/EX
- E** MS41 HERM SEALED (STANDARD)

**PNEUMATIC SWITCH**

- F** PS35
- G** PS45

**Step 5:<sup>4</sup>**

**/e/ INSULATION<sup>3</sup>**

- X** NO INSULATION
- IP** INSULATION PAD - ALL SERVICES **≥180°F (82°C)** PNEUMATIC SWITCHES ONLY ALL SERVICES **≥300°F (149°C)** ELECTRIC SWITCHES ONLY
- IH1** HIGH TEMP. INSULATION; FLOAT CHAMBER ONLY; 1/2"THICK, **250°F (121°C) MAX**
- IH1D** HIGH TEMP. INSULATION; FLOAT CHAMBER & VENT/ DRAIN FLANGES; 1/2"THICK, **250°F (121°C) MAX**
- IH2** HIGH TEMP. INSULATION; FLOAT CHAMBER ONLY; 1"THICK, **500°F (260°C) MAX**
- IH2D** HIGH TEMP. INSULATION; FLOAT CHAMBER & VENT/ DRAIN FLANGES; 1"THICK, **500°F (260°C) MAX**
- IH3** HIGH TEMP. INSULATION; FLOAT CHAMBER ONLY; 2"THICK, **900°F (482°C) MAX**
- IH3D** HIGH TEMP. INSULATION; FLOAT CHAMBER & VENT/ DRAIN FLANGES; 2"THICK, **900°F (482°C) MAX**
- IF** INSULATION FLANGE - RATED UP TO **900°F (482°C) MAX**
- IL1** CRYOGENIC INSULATION; 2"THICK; SINGLE LAYER; **-100°F (-73°C) MINIMUM**
- IL2** CRYOGENIC INSULATION; 3" THICK; DOUBLE LAYER; **-200°F (-129°C) MINIMUM**
- IL3** CRYOGENIC INSULATION; 4" THICK; DOUBLE LAYER; **-320°F (-196°C) MINIMUM**
- O** CUSTOM<sup>12</sup>

**Step 6:<sup>4</sup>**

**/h/ OPTIONS**

- X** NO OPTIONS
- CX** CUSTOM CALIBRATION<sup>5</sup>
- LX** CUSTOM CHAMBER LENGTH<sup>6</sup>
- VV** VENT VALVE<sup>7</sup>
- DV** DRAIN VALVE<sup>7</sup>
- IV** ISOLATION VALVE<sup>7</sup>
- IM** INTERFACE LEVEL MEASUREMENT<sup>8</sup>
- TT1** STEAM TRACE TUBING
- ET1xx** ELECTRIC TRACING; CLASS 1, DIV 2, GP BCD; **221°F(105°C) MAX**, FIXED SET POINT CONTROL<sup>11</sup>
- ET2x** ELECTRIC TRACING; CLASS 1, DIV 2, GP BCD; **400°F (204°C) MAX**, ADJUSTABLE SETPOINT CONTROL<sup>11</sup>
- ET3x** ELECTRIC TRACING; CLASS 1, DIV 2, GP BCD; **800°F (427°C) MAX**, ADJUSTABLE SETPOINT CONTROL<sup>11</sup>
- G** GUSSETS ON PROCESS CONNECTION (HIGH VIBRATION APPLICATIONS)
- O** CUSTOM<sup>12</sup>

**NOTE:** REFERENCE MODEL NUMBER SELECTION NOTES ON THE FOLLOWING PAGE

**NOTES:**

1. See Flange Pressure Rating Table in Appendix. Information in these tables is taken from ASME Standards. DIN, HG, or other International Flange Types require factory consultation.
2. See Switching Mechanisms and Housings on page 38-39. See Switch Mechanism Product Data Sheets for specifications.
3. See Insulation Descriptions on page 40; Insulation Jackets (IH) & Insulation Flange Covers are recommended for personnel safety.
4. Multiple Options: Separate multiple options with semi-colon (;) Example: ...x/B = 2-11/16 in; H = 287mm; .....
5. CX - Custom Calibration: C + "B" or "C" for required dimension (not "B" and "C") and engineering units (mm, in, cm) Example: ... x / CB=2-11/16 in; ..... See "Calibration Dimensions."
6. LX - Custom Length: L + "D" or "H" for required dimension (not "D" and "H") and engineering units (mm, in, cm) Example: ... x / LH = 287mm; ..... See "Dimension Tables."
7. See Valve Description on Page 41. Vent Valve (VV), Drain Valve (DV), Isolation Valves (IV) Customer to specify valve type and size.
8. Interface Level Measurement (IM) requires special consideration. Consult factory for details.
9. For Available Process Connections, see Tables 3 and 4 (p46-49) in Appendix.
10. Chamber Access Flange Types will be the same as Process Connections. If Process Connections are not flanges, Raised Face Slip-Ons will be the standard (unless otherwise specified).
11. Specify power supply 1) 110, 2) 220, 3) 277 or 4) 440 VAC) (ex. ET21= ET2 with 110VAC power supply). For ET1xx series only, specify setpoint A) 35°, B) 45°, C) 60°, D) 90° or E) 185°F (1.7°, 7.2°, 15.6°, 32.2°, or 85°C) (ex. ET11A = ET1 with 110VAC power supply and a setpoint of 35°F)
12. For options and selections not listed, write requirements after model number. Contact the ABB factory for price and availability.

## Calibration Dimensions for LS 800 series

1. "B" is the distance that the switch trips on rising level at the specified S.G.
2. "C" is the distance that the switch resets on falling level at the specified S.G.
3. The "B" dimension is the default switch calibration setting.
4. The "C" dimension will vary depending on the particular switch unit specified.
5. If a different "B" or the "C" dimension is required, it should be stated as shown under Options.
6. Calibration accuracy is +/- 1/4" (6mm)

800 Series 8x1		
S.G.	"B"	"C"
0.40	1-3/8"	4-7/16"
0.50	2-7/16"	5"
0.60	3-1/8"	5-5/16"
0.70	3-11/16"	5-9/16"
0.80	4-1/16"	5-3/4"
0.90	4-15/16"	5-15/16"

800 Series 8x2		
S.G.	"B"	"C"
0.40	1-3/8"	4-7/16"
0.50	2-7/16"	5"
0.60	3-1/8"	5-5/16"
0.70	3-11/16"	5-9/16"
0.80	4-1/16"	5-3/4"
0.90	4-15/16"	5-15/16"

800 Series 8x3		
S.G.	"B"	"C"
0.40	1-3/8"	4-7/16"
0.50	2-7/16"	5"
0.60	3-1/8"	5-5/16"
0.70	3-11/16"	5-9/16"
0.80	4-1/16"	5-3/4"
0.90	4-15/16"	5-15/16"

800 Series 8x4		
S.G.	"B"	"C"
0.40	2-15/16"	5-1/4"
0.50	3-3/4"	5-5/8"
0.60	4-5/16"	5-15/16"
0.70	4-11/16"	6-1/8"
0.80	5"	6-1/4"
0.90	5-3/16"	6-3/8"

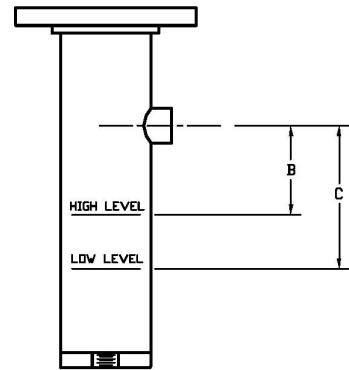

## Chamber Dimensions for LS 800 series

- See Tables on page 31 for dimensions for selected process connection size.
- Drawings not to scale.

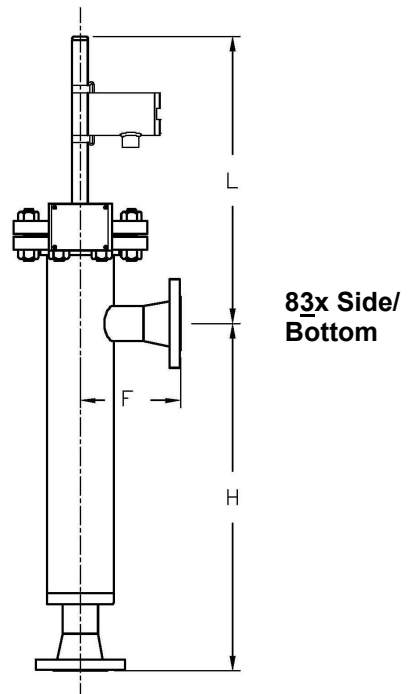
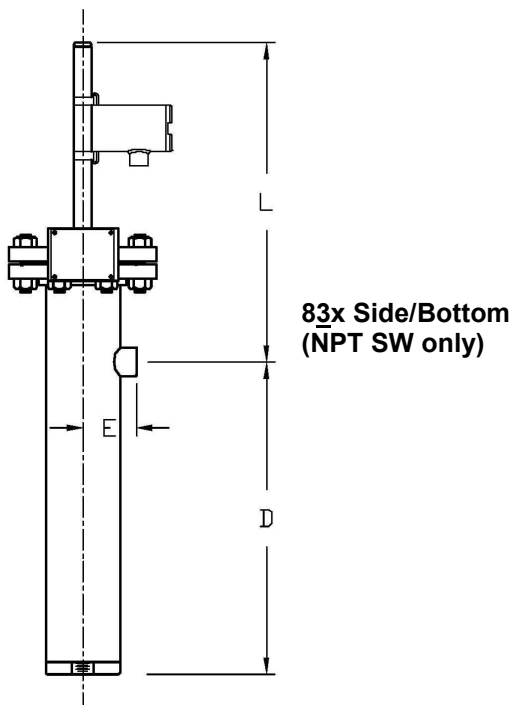
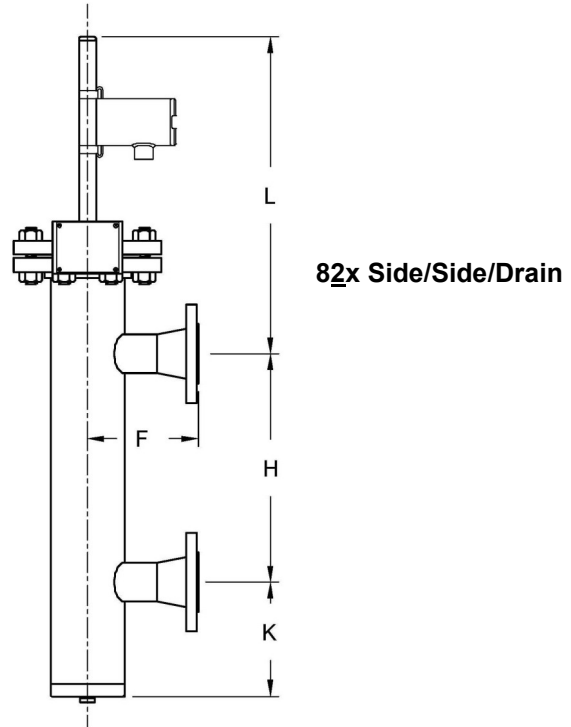
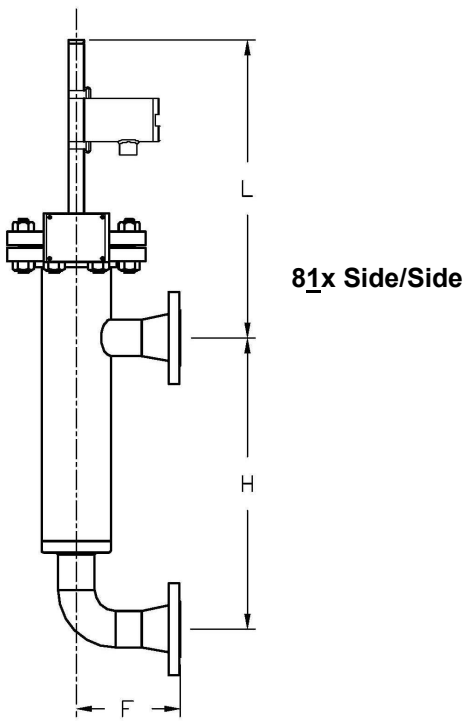

**Dimension Tables**

**1" Process Connection Dimension Table**

	D*		E*		F		H		K		L	
	inches	mm	inches	mm	inches	mm	inches	mm	inches	mm	inches	mm
8x1	13	330	3-3/16	81	TBD	TBD	16	406	TBD	TBD	TBD	TBD
8x2												
8x3												
8x4	11-1/2	292	3-11/16	94	TBD	TBD	16	406	TBD	TBD	TBD	TBD
8x5	12-3/4	324	3-15/16	100	TBD	TBD	16	406	TBD	TBD	TBD	TBD

\* These dimensions apply to Model 63x Side/Bottom with Threaded or Socket "Flange Type" only (see p.30)

**1-1/2" Process Connection Dimension Table**

	D*		E*		F		H		K		L	
	inches	mm	inches	mm	inches	mm	inches	mm	inches	mm	inches	mm
8x1	13	330	3-1/4	82	TBD	TBD	16	406	TBD	TBD	TBD	TBD
8x2												
8x3												
8x4	11-9/16	294	3-3/4	95	TBD	TBD	16	406	TBD	TBD	TBD	TBD
8x5	12-7/8	327	4-1/16	103	TBD	TBD	16	406	TBD	TBD	TBD	TBD

\* These dimensions apply to Model 63x Side/Bottom with Threaded or Socket "Flange Type" only (see p.30)

**2" Process Connection Dimension Table**

	D*		E*		F		H		K		L	
	inches	mm	inches	mm	inches	mm	inches	mm	inches	mm	inches	mm
8x1	/	/	/	/	TBD	TBD	16	406	TBD	TBD	TBD	TBD
8x2												
8x3												
8x4	11-11/16	297	3-7/8	98	TBD	TBD	16	406	TBD	TBD	TBD	TBD
8x5	13-1/4	337	4-7/16	113	TBD	TBD	16	406	TBD	TBD	TBD	TBD

\* These dimensions apply to Model 63x Side/Bottom with Threaded or Socket "Flange Type" only (see p.30)



## Sealed Chamber Displacer Series

### Model Number Formats

Series LS 9xx - Flanged Chamber Displacer					
<b>91x - Side / Side/ Process Connections</b>			<b>Example Application Data:</b> Pressure 1233psig, Temperature 122°F, S.G.0.46, 2" MNPT Thread		
<b>Example: LS911/CST/N3W7/SJ26/E/IH1/L=21"</b>					
Model (Series) (a)	Chamber Material (b)	Process Connection Size, Type & Rating (c)	Switching Mechanism Type (d)	Insulation (e)	Options (f)
911	CST	N3W7/SJ26	E	IH1	L=21"

### Step 1:

/a/ Select **PROCESS CONNECTION CONFIGURATION**.



**91x Side/Side**

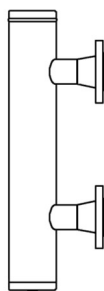

**92x Side/Side/Drain**

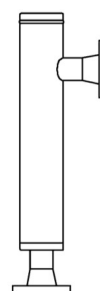

**93x Side/Bottom**

### Carbon Steel Chamber (A106 GrB)

Model Series	Pressure at Indicated Temperature				Float Mat'l Code	Minimum S.G.
	100° F (psig)	37.7° C (bar)	450° F (psig)	232° C (bar)		
9x1	1480	102.0	1380	95.1	S6	.4
9x2	1435	98.9	1380	95.1	S6	.4
9x3	3376	232.8	3376	232.8	S6	.4

Standard displacer units are not available above 450°F (232°C)

### Stainless Steel Chamber (316SS)

Model Series	Pressure at Indicated Temperature				Float Mat'l Code	Minimum S.G.
	100° F (psig)	37.7° C (bar)	450° F (psig)	232° C (bar)		
9x1	1480	102.0	1241	85.6	S6	.4
9x2	1480	102.0	1052	72.5	S6	.4
9x3	3601	248.3	2476	170.7	S6	.4

Standard displacer units are not available above 450°F (232°C)

Displacer Materials: 316 SS (S6) is the standard. The following materials and others are available. Hastelloy C276; Titanium Gr2, Titanium Gr5 and Porcelain. Construction materials are determined by application specifics (i.e. temperature, pressure and specific gravity).

Consult ABB factory for other chamber materials and process conditions not listed.

# Series LS 900

# Model Number Selection: Steps 2 - 6

## Step 2:

### /b/ CHAMBER MATERIAL

- CST** CARBON STEEL (STANDARD)
- SS6** 316 SS
- DUP** DUPLEX STAINLESS STEEL
- HSB** HASTELLOY B-3
- HSC** HASTELLOY C-276
- P11** P11 1.25%CHROME, MOLYBDENUM STEEL
- P91** P91 9% CHROME, MOLYBDENUM STEEL
- O** CUSTOM<sup>11</sup>

## Step 3:

### /c/ PROCESS CONNECTION SIZE TYPE & RATING<sup>1,9</sup>

SEE TABLES 3 & 4 (p46-49) IN APPENDIX

- O** CUSTOM<sup>11</sup>

## Step 4:<sup>4</sup>

### /d/ SWITCHING MECHANISM TYPE<sup>2</sup>

#### 10AMP DPDT CAM ACTION SWITCH

- C** MS40
- D** MS40/EX
- E** MS41 HERM SEALED (STANDARD)

#### PNEUMATIC SWITCH

- F** PS35
- G** PS45

## Step 5:<sup>4</sup>

### /e/ INSULATION<sup>3</sup>

- X** NO INSULATION
- IP** INSULATION PAD - ALL SERVICES  $\geq 180^{\circ}\text{F}$  ( $82^{\circ}\text{C}$ ) PNEUMATIC SWITCHES ONLY ALL SERVICES  $\geq 300^{\circ}\text{F}$  ( $149^{\circ}\text{C}$ ) ELECTRIC SWITCHES ONLY
- IH1** HIGH TEMP. INSULATION; FLOAT CHAMBER ONLY; 1/2"THICK,  $250^{\circ}\text{F}$  ( $121^{\circ}\text{C}$ ) MAX
- IH1D** HIGH TEMP. INSULATION; FLOAT CHAMBER & VENT/ DRAIN FLANGES; 1/2"THICK,  $250^{\circ}\text{F}$  ( $121^{\circ}\text{C}$ ) MAX
- IH2** HIGH TEMP. INSULATION; FLOAT CHAMBER ONLY; 1"THICK,  $500^{\circ}\text{F}$  ( $260^{\circ}\text{C}$ ) MAX
- IH2D** HIGH TEMP. INSULATION; FLOAT CHAMBER & VENT/ DRAIN FLANGES; 1"THICK,  $500^{\circ}\text{F}$  ( $260^{\circ}\text{C}$ ) MAX
- IH3** HIGH TEMP. INSULATION; FLOAT CHAMBER ONLY; 2"THICK,  $900^{\circ}\text{F}$  ( $482^{\circ}\text{C}$ ) MAX
- IH3D** HIGH TEMP. INSULATION; FLOAT CHAMBER & VENT/ DRAIN FLANGES; 2"THICK,  $900^{\circ}\text{F}$  ( $482^{\circ}\text{C}$ ) MAX
- IL1** CRYOGENIC INSULATION; 2"THICK; SINGLE LAYER;  $-100^{\circ}\text{F}$  ( $-73^{\circ}\text{C}$ ) MINIMUM
- IL2** CRYOGENIC INSULATION; 3" THICK; DOUBLE LAYER;  $-200^{\circ}\text{F}$  ( $-129^{\circ}\text{C}$ ) MINIMUM
- IL3** CRYOGENIC INSULATION; 4" THICK; DOUBLE LAYER;  $-320^{\circ}\text{F}$  ( $-196^{\circ}\text{C}$ ) MINIMUM
- O** CUSTOM<sup>11</sup>

## Step 6:<sup>4</sup>

### /h/ OPTIONS

- X** NO OPTIONS
- CX** CUSTOM CALIBRATION<sup>5</sup>
- LX** CUSTOM CHAMBER LENGTH<sup>6</sup>
- VV** VENT VALVE<sup>7</sup>
- DV** DRAIN VALVE<sup>7</sup>
- IV** ISOLATION VALVE<sup>7</sup>
- IM** INTERFACE LEVEL MEASUREMENT<sup>8</sup>
- TT1** STEAM TRACE TUBING
- ET1xx** ELECTRIC TRACING; CLASS 1, DIV 2, GP BCD;  $221^{\circ}\text{F}$  ( $105^{\circ}\text{C}$ ) MAX, FIXED SET POINT CONTROL<sup>10</sup>
- ET2x** ELECTRIC TRACING; CLASS 1, DIV 2, GP BCD;  $400^{\circ}\text{F}$  ( $204^{\circ}\text{C}$ ) MAX, ADJUSTABLE SETPOINT CONTROL<sup>10</sup>
- ET3x** ELECTRIC TRACING; CLASS 1, DIV 2, GP BCD;  $800^{\circ}\text{F}$  ( $427^{\circ}\text{C}$ ) MAX, ADJUSTABLE SETPOINT CONTROL<sup>10</sup>
- G** GUSSETS ON PROCESS CONNECTION (HIGH VIBRATION APPLICATIONS)
- O** CUSTOM<sup>11</sup>

**NOTE:** REFERENCE MODEL NUMBER SELECTION NOTES ON THE FOLLOWING PAGE

**NOTES:**

1. See Flange Pressure Rating Table in Appendix. Information in these tables is taken from ASME Standards. DIN, HG, or other International Flange Types require factory consultation.
2. See Switching Mechanisms and Housings on page 38 and 39. See Switch Mechanism Product Data Sheets for specifications.
3. See Insulation Descriptions on page 40; Insulation Jackets (IH) & Insulation Flange Covers (IF) are recommended for personnel safety.
4. Multiple Options: Separate multiple options with semi-colon (;) Example: ...x/B = 2-11/16 in; H = 287mm; .....
5. CX - Custom Calibration: C + "B" or "C" for required dimension (not "B" and "C") and engineering units (mm, in, cm) Example: .... x / CB=2-11/16 in; ..... See "Calibration Dimensions."
6. LX - Custom Length: L + "D" or "H" for required dimension (not "D" and "H") and engineering units (mm, in, cm) Example: .... x / LH = 287mm; ..... See "Dimension Tables."
7. See Valve Description on Page 41. Vent Valve (VV), Drain Valve (DV), Isolation Valves (IV) Customer to specify valve type and size.
8. Interface Level Measurement (IM) requires special consideration. Consult factory for details.
9. For Available Process Connections, see Tables 3 and 4 (p46-49) in Appendix.
10. Specify power supply 1) 110, 2) 220, 3) 277 or 4) 440 VAC) (ex. ET21= ET2 with 110VAC power supply). For ET1xx series only, specify setpoint A) 35°, B) 45°, C) 60°, D) 90° or E) 185°F (1.7°, 7.2°, 15.6°, 32.2°, or 85°C) (ex. ET11A = ET1 with 110VAC power supply and a setpoint of 35°F)
11. For options and selections not listed, write requirements after model number. Contact the ABB factory for price and availability.

## Calibration Dimensions for LS 900 series

1. "B" is the distance that the switch trips on rising level at the specified S.G.
2. "C" is the distance that the switch resets on falling level at the specified S.G.
3. The "B" dimension is the default switch calibration setting.
4. The "C" dimension will vary depending on the particular switch unit specified.
5. If a different "B" or the "C" dimension is required, it should be stated as shown under Options.
6. Calibration accuracy is +/- 1/4" (6mm)

900 Series 9x1		
S.G.	"B"	"C"
0.40	1-3/8"	4-7/16"
0.50	2-7/16"	5"
0.60	3-1/8"	5-5/16"
0.70	3-11/16"	5-9/16"
0.80	4-1/16"	5-3/4"
0.90	4-15/16"	5-15/16"

900 Series 9x2		
S.G.	"B"	"C"
0.40	1-3/8"	4-7/16"
0.50	2-7/16"	5"
0.60	3-1/8"	5-5/16"
0.70	3-11/16"	5-9/16"
0.80	4-1/16"	5-3/4"
0.90	4-15/16"	5-15/16"

900 Series 9x3		
S.G.	"B"	"C"
0.40	2-15/16"	5-1/4"
0.50	3-3/4"	5-5/8"
0.60	4-5/16"	5-15/16"
0.70	4-11/16"	6-1/8"
0.80	5"	6-1/4"
0.90	5-3/16"	6-3/8"

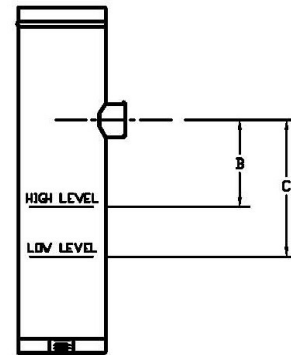

## Chamber Dimensions for LS 900 series

- See Tables on page 37 for dimensions for selected process connection size.
- Drawings not to scale.

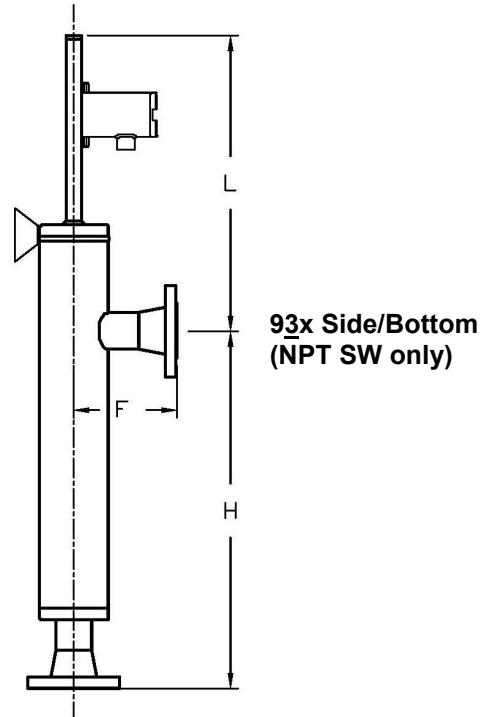
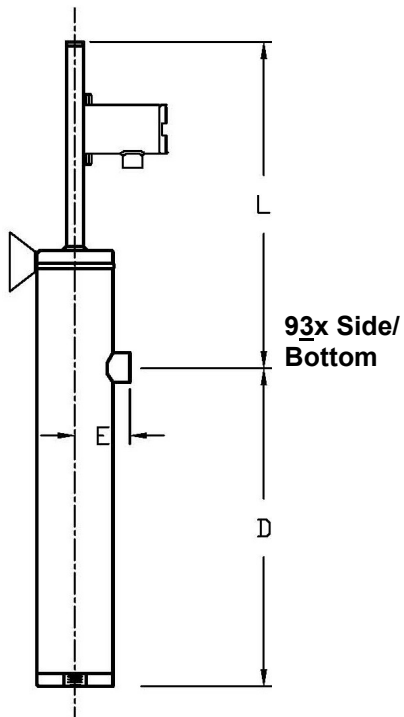
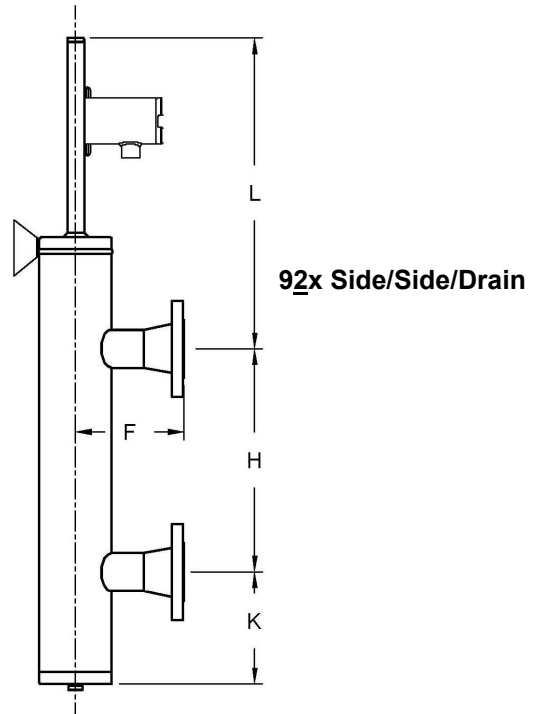
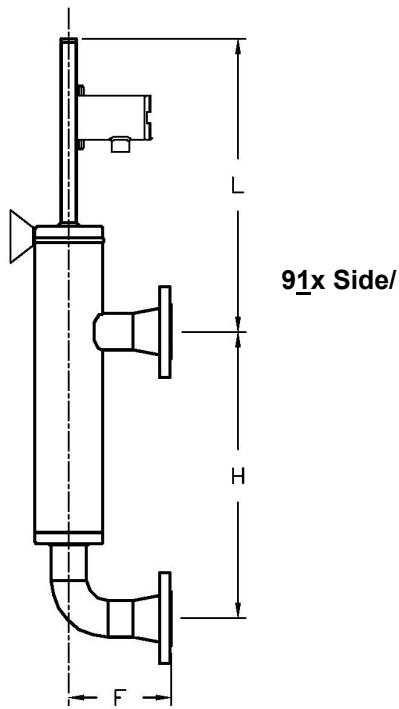

**Dimension Tables**

**1" Process Connection Dimension Table**

	D*		E*		F		H		K		L	
	inches	mm	inches	mm	inches	mm	inches	mm	inches	mm	inches	mm
9x1	13	330	3-3/16	81	TBD	TBD	16	406	TBD	TBD	TBD	TBD
9x2	11-1/2	292	3-11/16	94	TBD	TBD	16	406	TBD	TBD	TBD	TBD
9x3	12-3/4	324	3-15/16	100	TBD	TBD	16	406	TBD	TBD	TBD	TBD

\* These dimensions apply to Model 63x Side/Bottom with Threaded or Socket "Flange Type" only (see p.36)

**1-1/2" Process Connection Dimension Table**

	D*		E*		F		H		K		L	
	inches	mm	inches	mm	inches	mm	inches	mm	inches	mm	inches	mm
9x1	13	330	3-1/4	82	TBD	TBD	16	406	TBD	TBD	TBD	TBD
9x2	11-9/16	294	3-3/4	95	TBD	TBD	16	406	TBD	TBD	TBD	TBD
9x3	12-7/8	327	4-1/16	103	TBD	TBD	16	406	TBD	TBD	TBD	TBD

\* These dimensions apply to Model 63x Side/Bottom with Threaded or Socket "Flange Type" only (see p.36)

**2" Process Connection Dimension Table**

	D*		E*		F		H		K		L	
	inches	mm	inches	mm	inches	mm	inches	mm	inches	mm	inches	mm
9x1					TBD	TBD	16	406	TBD	TBD	TBD	TBD
9x2	11-11/16	297	3-7/8	99	TBD	TBD	16	406	TBD	TBD	TBD	TBD
9x3	13-1/4	337	4-7/16	113	TBD	TBD	16	406	TBD	TBD	TBD	TBD

\* These dimensions apply to Model 63x Side/Bottom with Threaded or Socket "Flange Type" only (see p.36)

The switch point of LS Series level switches is dependent upon the specific gravity of the process fluid and other factors. As specific gravity decreases, the distance between the centerline of the upper process connection and the fluid level at which the switch transfers decreases. This is due to the additional amount of fluid required to make the float buoyant at the lower specific gravity. This means that actual fluid levels at the switch transfer point vary with specific gravity.

The function of the LS Series level switch depends upon the movement of a magnet assembly within the switch post to activate an external switch. In order to begin moving up with rising fluid level, a small amount of static friction must be overcome. To facilitate this additional force, the floats are designed with reserve buoyancy to provide force for movement and to provide buoyancy with decreases in specific gravity. This reserve buoyancy is in the form of the amount of float that is above the fluid level. In order for the reserve buoyancy to be useful, it must be located where fluid may actually reach it. As a standard, we design the floats so that the top is even with the centerline of the upper process connection when the magnet assembly is all the way to the top of the sensor tube. This allows standardization of all chambers for manufacturing. The fluid level at switching is then a function of the specific gravity and the float selected.

Dead-band of a magnetically operated switch is the distance a magnet must travel to transfer from one state to another. Switch transfer dead-band is a function of the type of switch selected and the strength of the magnetic field. The reed switch variety have only a small dead-band, while the cam actuated switches have larger dead-bands. Because the dead-band is different for each switch type, we set LS Series switches to either the High (rising fluid (standard)) or the Low (falling fluid) reference point on the LS Series sensor tube per the customer's requirements. The operation of the switch in the opposite direction is the dead-band distance. The location of the on/off points for each type of switch is consistent for that type, and is therefore known and placed on the sensor tube at the reference point on the sensor tube.

The LS Series is constructed such that sufficient over-travel past the switch point occurs to ensure proper operation no matter what switch type is used. This allowed over-travel increases the distance from the centerline of the upper process connection to the fluid level at the high switch point. This value is fixed at 11/16" for existing switch requirements. A difference of 13/16" between the high and low reference points has also been established due to existing switch requirements. Therefore, the high switch point is determined by the 11/16" over-travel plus the length of the float above the fluid level at the specific gravity specified. The low switch point is determined by the 11/16" over-travel plus the 13/16" difference between the reference points and the length of the float above the fluid level at the specific gravity specified.

The following "magnetically activated" switching mechanisms in Table 1 are available and ready for use with the LS Series Switches. This table provides details on specific switching mechanism applicability. All switching mechanisms are available with the European CE mark. Consult the KTEK factory for certification/documentation. In high corrosive applications, ABB recommends the use of stainless steel housings over aluminum enclosures. Please see product data sheets on the KTEK website at [www.ktekcorp.com](http://www.ktekcorp.com) for the latest specifications and approvals.

Table 1

Model #	Agency Approvals	Enclosure			Switching Mechanism						Application		
		Type	Ratings	Electrical Connection	Type	Ratings	Min Process Temp	Max Process Temp	Dead-band	Contacts	High Temp	Vibration	High Corrosion
MS30	FM, CSA	Hermetically Sealed	NEMA 4x	1/2" MNPT	Reed	AC/DC 1amp	-40°F (-40°C)	300°F (149°C); 600°F (316°C) with IP option	1/8"	SPDT	●		
MS30/EX	FM, CSA	Hermetically Sealed, Explosion Proof	NEMA 4x	1/2" FNPT	Reed	AC/DC 1amp	-40°F (-40°C)	300°F (149°C); 600°F (316°C) with IP option	1/8"	SPDT	●		
MS40	FM, CSA	Stainless Steel	NEMA 4x	1/2" FNPT	Cam Driven, Snap Action	AC:10amp DC: 2.6 amp	-60°F (-51°C)	300°F (149°C); 600°F (316°C) with IP option	7/8"	DPDT	●	●	●
MS40/EX	FM, CSA	Stainless Steel, Explosion Proof	NEMA 4x	3/4" FNPT	Cam Driven, Snap Action	AC:10amp DC:1/2 amp	-60°F (-51°C)	300°F (149°C); 600°F (316°C) with IP option	13/16"	DPDT	●	●	●
MS41	FM, CSA, ATEX	Stainless Steel, Dual Compartment, Hermetically Sealed, Explosion Proof	NEMA 4x	1/2" FNPT	Cam Driven, Snap Action	AC: 10amp DC: 2.6 amp	-320°F (-195°C) with option	300°F (149°C); 1000°F (538°C) with IP option	15/16"	DPDT	●	●	●
PS35	Non-electric	Stainless Steel	NEMA 4x	1/8" MNPT port	Pneumatic	15 to 100 psig	0°F (-18°C)	180°F (82°C); 450°F (232°C) with IP option	1"	Pneumatic Signal			●
PS45	Non-electric	Stainless Steel	NEMA 4x	1/8" MNPT port	Pneumatic	1 to 100 psig	0°F (-18°C)	180°F (82°C); 450°F (232°C) with IP option	15/16"	Pneumatic Signal			●



# Mechanical Level Switches

# Options/Insulation

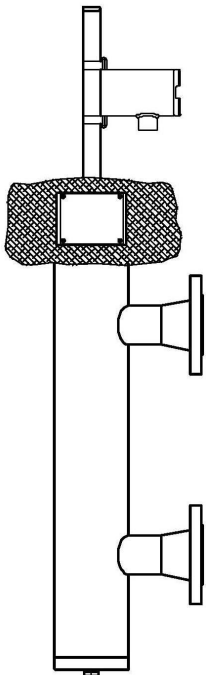

**IF**  
INSULATION FLANGE- RATED UP  
TO 900°F (482°C) MAX

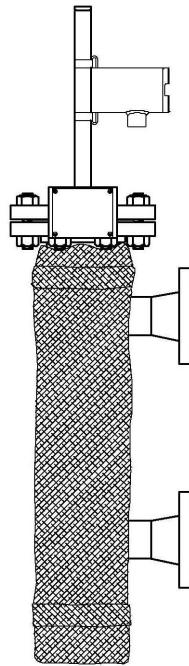

**IHx**  
INSULATION JACKET HIGH  
TEMPERATURE - RATED  
UP TO 900°F (482°C) MAX

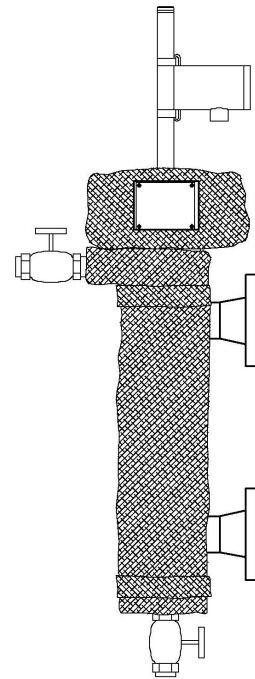

**IHxD**  
INSULATION WRAP INCLUDES  
JACKET, FLANGE, VALVES AND  
PROCESS CONNECTIONS  
RATED UP TO 900°F (482°C) MAX

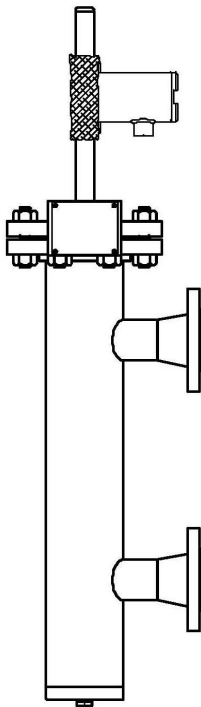

**IP**  
INSULATION PAD -ALL SERVICES  $\geq 180^{\circ}\text{F}$   
(82°C) PNEUMATIC SWITCHES ONLY  
ALL SERVICES  $\geq 300^{\circ}\text{F}$  (149°C) ELECTRIC  
SWITCHES ONLY

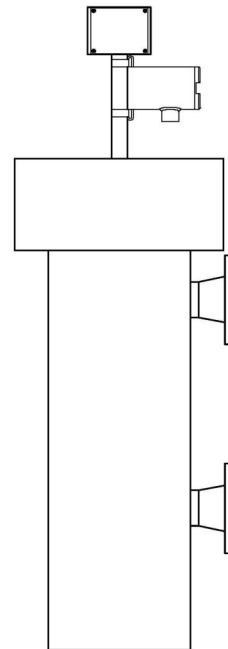

**ILx**  
INSULATION -  
CRYOGENIC SERVICES  
RATED DOWN TO -320°F (-196°C) MIN

**NOTE:** KTEK recommends for Process Temperatures  $\geq 150^{\circ}\text{F}$  (66°C) the use of **IHx**, **IF** or **IHxD** for personnel safety.

**NOTE:** Consult ABB factory for overall physical dimensions of cryogenic units.

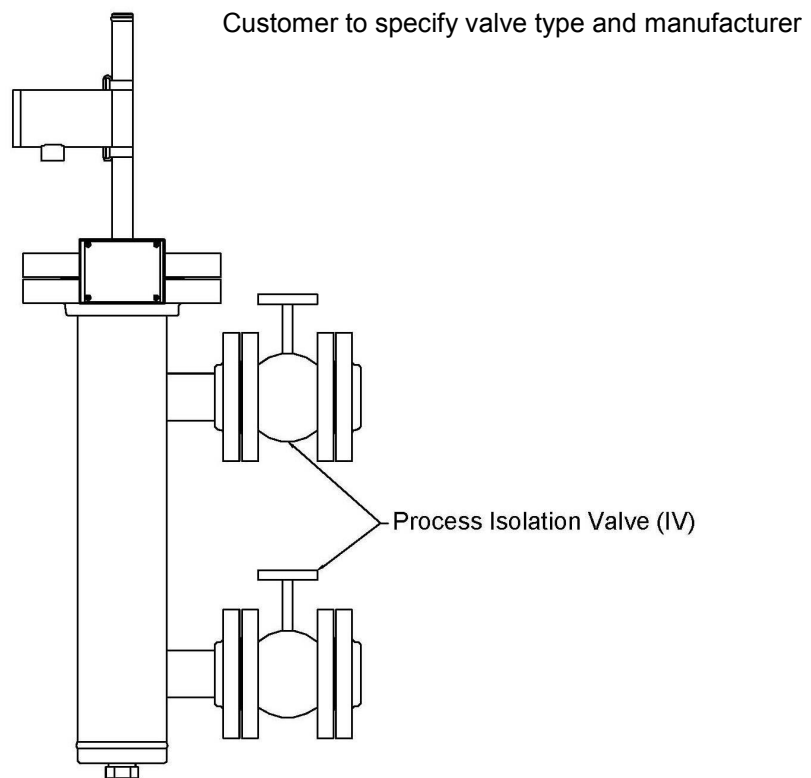
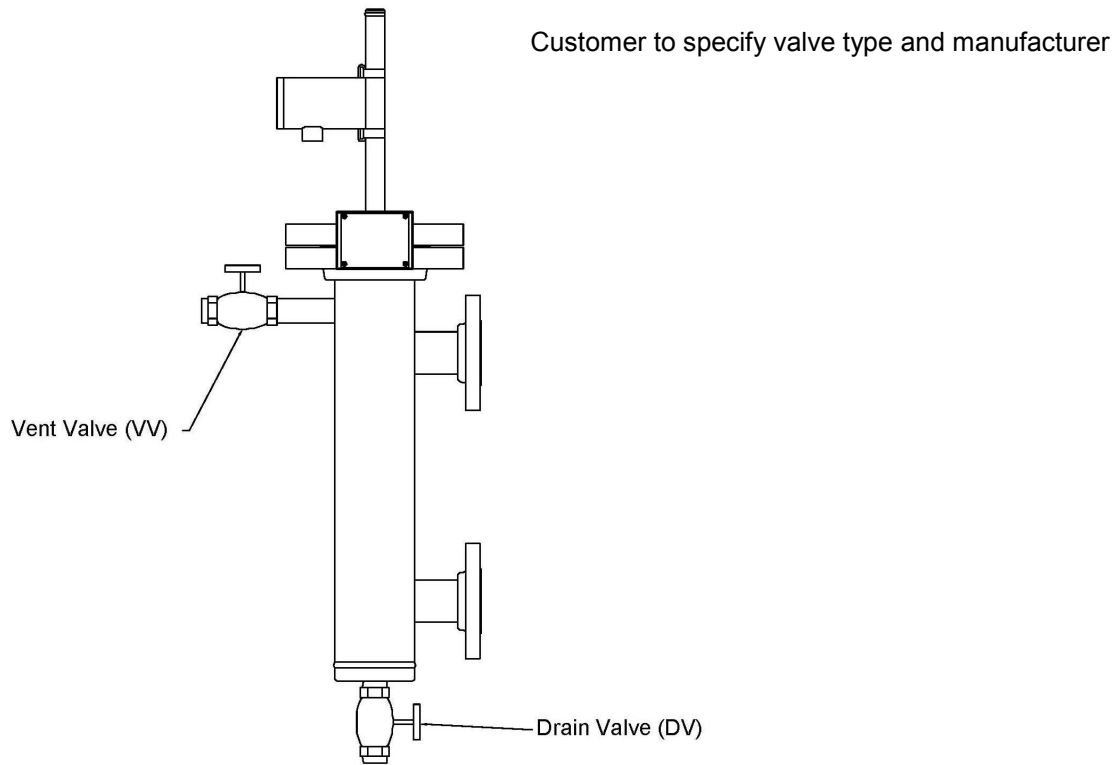

# Mechanical Level Switches

# Options/Stilling Wells

**NOTE:** Stilling Well (SW) dimensions are determined by customer application. ABB recommends the use of Stilling Wells (SW) or Existing Chambers (CAGES) on all Top Mount Units  $\geq 24$ " insertion length. Consult factory on the use of Support Tubes (ST). See illustrations below.

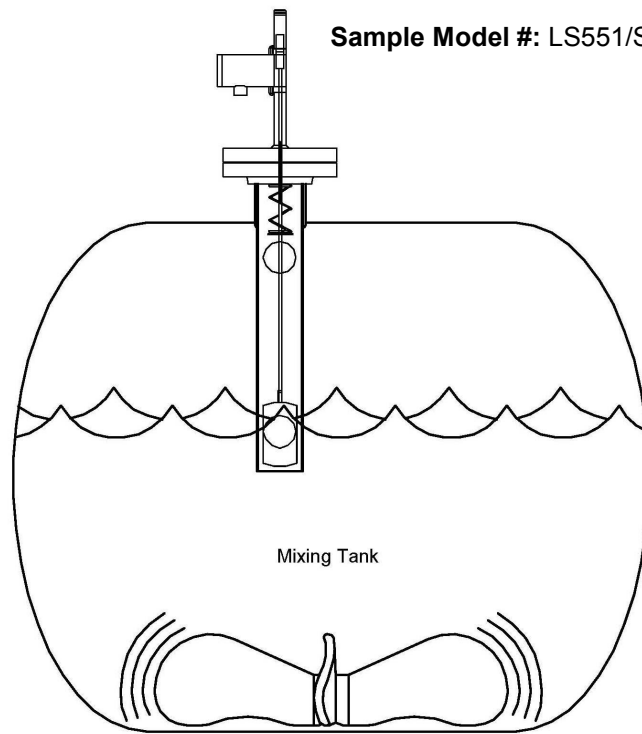

**Sample Model #:** LS551/SS6/SR41/E/X/SW; SP=17-1/4"

**Sample Model #:** LS502/CST/  
WR256/E/X/ST; SP=60 -1/2"

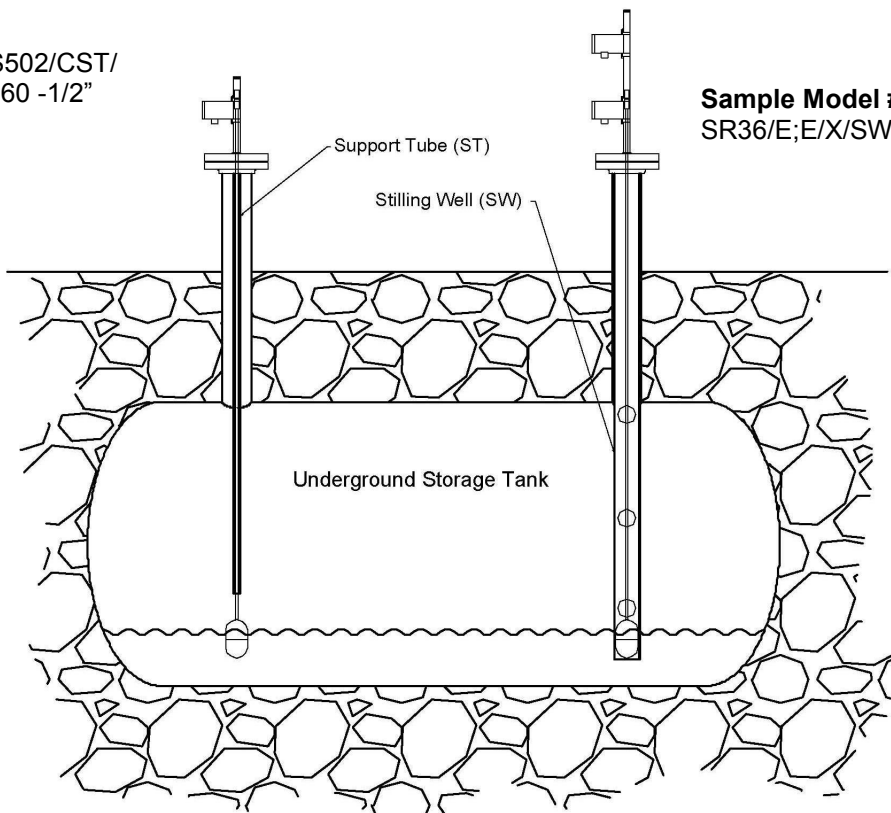

**Sample Model #:** LS501/SS6/  
SR36/E;E/X/SW; SP1=56",

**Table 1 Typical Pressure for Various Materials**

**A106B CARBON STEEL**

Pipe Size	Pipe Schedule	100°F (38°C)	200°F (93°C)	300°F (149°C)	400°F (204°C)	500°F (260°C)	600°F (316°C)	650°F (343°C)	700°F (371°C)	750°F (399°C)
1"	40	2857	2857	2857	2857	2857	2857	2857	2743	2476
	80	3950	3950	3950	3950	3950	3950	3950	3792	3423
	160	5757	5757	5757	5757	5757	5757	5757	5526	4989
1-1/2"	40	2116	2116	2116	2116	2116	2116	2116	2032	1834
	80	2983	2983	2983	2983	2983	2983	2983	2864	2585
	160	4331	4331	4331	4331	4331	4331	4331	4157	3753
2"	40	1783	1783	1783	1783	1783	1783	1783	1712	1545
	80	2575	2575	2575	2575	2575	2575	2575	2472	2232
	160	4217	4217	4217	4217	4217	4217	4217	4049	3655
3"	40	1693	1693	1693	1693	1693	1693	1693	1625	1467
	80	2394	2394	2394	2394	2394	2394	2394	2298	2074
	160	3600	3600	3600	3600	3600	3600	3600	3456	3120
4"	40	1435	1435	1435	1435	1435	1435	1435	1378	1244
	80	2075	2075	2075	2075	2075	2075	2075	1992	1798
	160	3376	3376	3376	3376	3376	3376	3376	3241	2926
5"	40	1258	1258	1258	1258	1258	1258	1258	1208	1090
	80	1857	1857	1857	1857	1857	1857	1857	1783	1610
	160	3201	3201	3201	3201	3201	3201	3201	3073	2774
6"	40	1143	1143	1143	1143	1143	1143	1143	1098	991
	80	1794	1794	1794	1794	1794	1794	1794	1722	1554
	160	3083	3083	3083	3083	3083	3083	3083	2960	2672
8"	40	1006	1006	1006	1006	1006	1006	1006	966	872
	80	1586	1586	1586	1586	1586	1586	1586	1523	1375
	160	2976	2976	2976	2976	2976	2976	2976	2857	2579
10"	40	913	913	913	913	913	913	913	876	791
	80	1509	1509	1509	1509	1509	1509	1509	1448	1308
	160	2950	2950	2950	2950	2950	2950	2950	2832	2557

Ratings are given for standard seamless pipe sizes at temperatures from 100°F (38°C) to 750°F(399°C). All ratings are in psig and are based on ANSI/ASME B31.1.

**Table 1 (continued)**

**A312-TP316/316SS**

Pipe Size	Pipe Schedule	100°F (38°C)	200°F (93°C)	300°F (149°C)	400°F (204°C)	500°F (260°C)	600°F (316°C)	650°F (343°C)	700°F (371°C)	750°F (399°C)
1"	40	3048	2629	2362	2171	2019	1924	1867	1824	1810
	80	4213	3634	3265	3002	2791	2659	2580	2528	2501
	160	6140	5296	4759	4375	4068	3876	3761	3684	3646
1-1/2"	40	2257	1947	1750	1608	1496	1425	1383	1354	1340
	80	3182	2744	2466	2267	2108	2009	1949	1909	1889
	160	4619	3984	3580	3291	3060	2916	2829	2772	2743
2"	40	1902	1640	1474	1355	1260	1201	1165	1141	1129
	80	2747	2369	2129	1957	1820	1734	1682	1648	1631
	160	4499	3880	3486	3205	2980	2840	2755	2699	2671
3"	40	1806	1558	1400	1287	1196	1140	1106	1084	1072
	80	2553	2202	1979	1819	1691	1612	1564	1532	1516
	160	3840	3312	2976	2736	2544	2424	2352	2304	2280
4"	40	1531	1321	1187	1091	1014	967	938	919	909
	80	2213	1909	1715	1577	1466	1397	1355	1328	1314
	160	3601	3106	2791	2566	2386	2273	2206	2161	2138
5"	40	1342	1158	1040	956	889	847	822	805	797
	80	1981	1709	1535	1411	1312	1250	1213	1189	1176
	160	3414	2945	2646	2433	2262	2155	2091	2049	2027
6"	40	1219	1052	945	869	808	770	747	732	724
	80	1913	1650	1483	1363	1267	1208	1172	1148	1136
	160	3289	2836	2549	2343	2179	2076	2014	1973	1953
8"	40	1073	926	832	765	711	678	657	644	637
	80	1692	1459	1311	1205	1121	1068	1036	1015	1005
	160	3175	2738	2460	2262	2103	2004	1944	1905	1885
10"	40	974	840	755	694	645	615	596	584	578
	80	1609	1388	1247	1147	1066	1016	986	966	956
	160	3147	2714	2439	2242	2085	1986	1927	1880	1868

Ratings are given for standard seamless pipe sizes at temperatures from 100°F (38°C) to 750°F(399° C). All ratings are in psig and are based on ANSI/ASME B31.1.

**Table 2**

**A105 CARBON STEEL**

Class	100°F (38°C)	200°F (93°C)	300°F (149°C)	400°F (204°C)	500°F (260°C)	600°F (316°C)	650°F (343°C)	700°F (371°C)	750°F (399°C)
150#	285	260	230	200	170	140	125	110	95
300#	740	680	655	635	605	570	550	530	505
600#	1480	1360	1310	1265	1205	1135	1100	1060	1015
900#	2220	2035	1965	1900	1810	1705	1650	1590	1520
1500#	3705	3395	3270	3170	3015	2840	2745	2655	2535
2500#	6170	5655	5450	5280	5025	4730	4575	4425	4230

**A182-F316/316L STAINLESS STEEL**

Class	100°F (38°C)	200°F (93°C)	300°F (149°C)	400°F (204°C)	500°F (260°C)	600°F (316°C)	650°F (343°C)	700°F (371°C)	750°F (399°C)
150#	275	235	215	195	170	140	125	110	95
300#	720	620	560	515	480	450	440	435	425
600#	1440	1240	1120	1025	955	900	885	870	855
900#	2160	1860	1680	1540	1435	1355	1325	1305	1280
1500#	3600	3095	2795	2570	2390	2255	2210	2170	2135
2500#	6000	5160	4660	4280	3980	3760	3680	3620	3560

**B574 HASTELLOY-C**

Class	100°F (38°C)	200°F (93°C)	300°F (149°C)	400°F (204°C)	500°F (260°C)	600°F (316°C)	650°F (343°C)	700°F (371°C)	750°F (399°C)
150#	290	260	230	200	170	140	125	110	95
300#	750	750	730	700	665	605	590	570	530
600#	1500	1500	1455	1395	1330	1210	1175	1135	1065
900#	2250	2250	2185	2095	1995	1815	1765	1705	1595
1500#	3750	3750	3640	3490	3325	3025	2940	2840	2660
2500#	6250	6250	6070	5820	5540	5040	4905	4730	4430

**B462 ALLOY-20**

Class	100°F (38°C)	200°F (93°C)	300°F (149°C)	400°F (204°C)	500°F (260°C)	600°F (316°C)	650°F (343°C)	700°F (371°C)	750°F (399°C)
150#	290	260	230	200	170	140	125	110	95
300#	750	740	710	680	655	605	590	570	530
600#	1500	1485	1420	1365	1310	1210	1175	1135	1065
900#	2250	2225	2130	2045	1965	1815	1765	1705	1595
1500#	3750	3710	3550	3410	3275	3025	2940	2840	2660
2500#	6250	6180	5920	5680	5460	5040	4905	4730	4430

**A182-F12 CHROME MOLY STEEL**

Class	100°F (38°C)	200°F (93°C)	300°F (149°C)	400°F (204°C)	500°F (260°C)	600°F (316°C)	650°F (343°C)	700°F (371°C)	750°F (399°C)
150#	290	260	230	200	170	140	125	110	95
300#	750	735	700	670	645	605	590	570	530
600#	1500	1470	1400	1335	1290	1210	1175	1135	1065
900#	2250	2210	2100	2005	1940	1815	1765	1705	1595
1500#	3750	3680	3495	3345	3230	3025	2940	2840	2660
2500#	6250	6135	5830	5570	5385	5040	4905	4730	4430

**Note:** All pressures given in psig. Flange size does not affect pressure rating. Pressure rating is based on flange class only. All ratings are based on ASME B16.5.-2003, DIN, HG, or other international flange types available but require factory consultation

**Table 3: Schematic Illustration of Available Connections**

C0	C0L	C0E	C1	C1L	C2	FE	F0E
F0	F1	F2	F3	F3E	F4	GE	G
G1	G4	L	N0E	N0	N2E	N2	N3E
N3	N6	SW	SWE	X	T0	T2	T3
T4	T5	T6	T7	T9	W0	W1	W2
W3	W4	W5	W6	W7	W9	W10	

**Note:** Please see Option Code Table on page 47

Table 3 (Continued)

Description of Option Codes																		
<b>C0</b>	FNPT Coupling	<b>SW</b>	Socket Weld Flange <sup>1</sup>															
<b>C0E</b>	FNPT Coupling Connected Via Extruded Outlet <sup>2</sup>	<b>SWE</b>	Socket Weld Flange Connected Via Extruded Outlet <sup>2</sup>															
<b>C0L</b>	Thread-o-let (Min SCH 40 Chamber)	<b>T0</b>	Butt Welded Dome Pipe Cap															
<b>C1</b>	Socket Weld Coupling	<b>T2</b>	T0 with FNPT Coupling and Plug															
<b>C1L</b>	Sock-o-let (Min SCH 40 Chamber)	<b>T3</b>	T0 with Socket Weld Coupling															
<b>C2</b>	C0 with plug	<b>T4</b>	T0 with FNPT Coupling															
<b>FE</b>	Weld Neck Flange Connected Via Extruded Outlet <sup>2</sup>	<b>T5</b>	T0 with Nipple, for Socket Welding (Flat end)															
<b>F0</b>	Weld Neck Flange <sup>1</sup>	<b>T6</b>	T0 with Nipple, for Butt Welding (37.5° Beveled end)															
<b>F0E</b>	FE with pipe between chamber and Weld Neck Flange	<b>T7</b>	T0 with Nipple, MNPT															
<b>F1</b>	Weld Neck Flange with Weld-o-let (Min SCH 40 Chamber)	<b>T9</b>	T0 With Nipple and Flange															
<b>F2</b>	Weld Neck Flange with Weld-o-let and Concentric Reducer (Min SCH 40 Chamber)	<b>W0</b>	Welded Flat Pipe Cap with Float Stop Spring															
<b>F3</b>	Weld Neck Flange with Concentric Reducer	<b>W1</b>	W0 with FNPT <sup>3</sup> ; 1/2" FNPT standard															
<b>F3E</b>	Weld Neck Flange with Concentric Reducer Connected Via Extruded Outlet <sup>2</sup>	<b>W2</b>	W0 with Plug <sup>5</sup> ; 1/2" Standard															
<b>F4</b>	Weld Neck Flange with Butt Weld Tee	<b>W3</b>	W0 with Socket Weld Coupling															
<b>GE</b>	Slip-On Flange Connected Via Extruded Outlet <sup>2</sup>	<b>W4</b>	W0 with FNPT Coupling															
<b>G</b>	Slip-On Flange <sup>1</sup>	<b>W5</b>	W0 with Nipple, for Socket Welding (Flat end)															
<b>G1</b>	Slip-On Flange with Weld-O Let and Pipe Nipple	<b>W6</b>	W0 with Nipple, for Butt Welding (37.5° Beveled end)															
<b>G4</b>	Slip-On Flange with Butt Weld Tee and Pipe Nipple	<b>W7</b>	W0 with Nipple, MNPT															
<b>L</b>	Stub End with Loose (Lap Joint) Flange	<b>W9</b>	W0 with Nipple and Flange <sup>6</sup>															
		<b>W10</b>	W0 with Socket Weld Bore <sup>4</sup> ; 1/2" SW Standard															
<b>N0E</b>	Branch Nipple for Socket Weld (Flat end) Connected Via Extruded Outlet <sup>2</sup>	<b>X</b>	No Connection															
<b>N0</b>	Branch Nipple for Socket Weld (Flat end)																	
<b>N2</b>	Branch Nipple for Butt Welding (37.5° Beveled end)																	
<b>N2E</b>	Branch Nipple for Butt Welding (37.5° Beveled end) Connected Via Extruded Outlet <sup>2</sup>																	
<b>N3</b>	MNPT Branch Nipple																	
<b>N3E</b>	MNPT Branch Nipple Connected Via Extruded Outlet <sup>2</sup>																	
<b>N6</b>	Weld-o-let (Min SCH 40 Chamber)																	
<p><b>Notes:</b></p> <p>1: Extruded outlet can be utilized as follows</p> <table border="0"> <thead> <tr> <th></th> <th><u>FLANGES &amp; NIPPLES</u></th> <th><u>COUPLING SIZES</u></th> </tr> </thead> <tbody> <tr> <td>Stainless Steel:</td> <td>Sch. 10 chambers with 1", 1-1/2" &amp; 2" connections</td> <td>3/4", 1", 1-1/4"</td> </tr> <tr> <td></td> <td>Sch. 40 chambers with 1-1/2" &amp; 2" connections<sup>2</sup></td> <td>1-1/4"</td> </tr> <tr> <td>Alloy20:</td> <td>Sch. 10 chambers with 1-1/2" &amp; 2" connections</td> <td>1-1/4"</td> </tr> <tr> <td>Hastelloy:</td> <td>Sch. 10 chambers with 1-1/2" &amp; 2" connections</td> <td>1-1/4"</td> </tr> </tbody> </table> <p>2: Cannot extrude SCH 40 seamless pipe            3: 1/2" FNPT Standard; Optional FN7 (3/4") or FN1 (1"). Specify after option. (i.e.: W1FN7)            4: 1/2" SW Standard; Optional SW7 (3/4"). Specify after option. (i.e.: W10SW7)            5: 1/2" plug Standard; see Table 4 (Page 49) for additional sizes.            6: Select T9 or W9 when chamber configuration is top side/ bottom bottom.</p>					<u>FLANGES &amp; NIPPLES</u>	<u>COUPLING SIZES</u>	Stainless Steel:	Sch. 10 chambers with 1", 1-1/2" & 2" connections	3/4", 1", 1-1/4"		Sch. 40 chambers with 1-1/2" & 2" connections <sup>2</sup>	1-1/4"	Alloy20:	Sch. 10 chambers with 1-1/2" & 2" connections	1-1/4"	Hastelloy:	Sch. 10 chambers with 1-1/2" & 2" connections	1-1/4"
	<u>FLANGES &amp; NIPPLES</u>	<u>COUPLING SIZES</u>																
Stainless Steel:	Sch. 10 chambers with 1", 1-1/2" & 2" connections	3/4", 1", 1-1/4"																
	Sch. 40 chambers with 1-1/2" & 2" connections <sup>2</sup>	1-1/4"																
Alloy20:	Sch. 10 chambers with 1-1/2" & 2" connections	1-1/4"																
Hastelloy:	Sch. 10 chambers with 1-1/2" & 2" connections	1-1/4"																



**Table 4**

Flanged Connections											
Size	Pressure Rating	Loose Flange	Slip On Flanges				Socket Weld Flanges	Weld Neck Flanges			
			Raised Face	RTJ	Tongue & Groove	Male/Female	Raised Face	Raised Face	RTJ	Tongue & Groove	Male/Female
1/2"	150#	L51	SR51	SJ51	ST51	SM51	SWR51	WR51	WJ51	WT51	WM51
1/2"	300#	L53	SR53	SJ53	ST53	SM53	SWR53	WR53	WJ53	WT53	WM53
1/2"	600#	L56	SR56	SJ56	ST56	SM56	SWR56	WR56	WJ56	WT56	WM56
1/2"	1500#	L515	SR515	SJ515	ST515	SM515	SWR515	WR515	WJ515	WT515	WM515
3/4"	150#	L71	SR71	SJ71	ST71	SM71	SWR71	WR71	WJ71	WT71	WM71
3/4"	300#	L73	SR73	SJ73	ST73	SM73	SWR73	WR73	WJ73	WT73	WM73
3/4"	600#	L76	SR76	SJ76	ST76	SM76	SWR76	WR76	WJ76	WT76	WM76
3/4"	1500#	L715	SR715	SJ715	ST715	SM715	SWR715	WR715	WJ715	WT715	WM715
1"	150#	L11	SR11	SJ11	ST11	SM11	SWR11	WR11	WJ11	WT11	WM11
1"	300#	L13	SR13	SJ13	ST13	SM13	SWR13	WR13	WJ13	WT13	WM13
1"	600#	L16	SR16	SJ16	ST16	SM16	SWR16	WR16	WJ16	WT16	WM16
1"	1500#	L115	SR115	SJ115	ST115	SM115	SWR115	WR115	WJ115	WT115	WM115
1-1/2"	150#	L151	SR151	SJ151	ST151	SM151	SWR151	WR151	WJ151	WT151	WM151
1-1/2"	300#	L153	SR153	SJ153	ST153	SM153	SWR153	WR153	WJ153	WT153	WM153
1-1/2"	600#	L156	SR156	SJ156	ST156	SM156	SWR156	WR156	WJ156	WT156	WM156
1-1/2"	1500#	L1515	SR1515	SJ1515	ST1515	SM1515	SWR1515	WR1515	WJ1515	WT1515	WM1515
2"	150#	L21	SR21	SJ21	ST21	SM21	SWR21	WR21	WJ21	WT21	WM21
2"	300#	L23	SR23	SJ23	ST23	SM23	SWR23	WR23	WJ23	WT23	WM23
2"	600#	L26	SR26	SJ26	ST26	SM26	SWR26	WR26	WJ26	WT26	WM26
2"	1500#	L215	SR215	SJ215	ST215	SM215	SWR215	WR215	WJ215	WT215	WM215
2-1/2"	150#	L251	SR251	SJ251	ST251	SM251	SWR251	WR251	WJ251	WT251	WM251
2-1/2"	300#	L253	SR253	SJ253	ST253	SM253	SWR253	WR253	WJ253	WT253	WM253
2-1/2"	600#	L256	SR256	SJ256	ST256	SM256	SWR256	WR256	WJ256	WT256	WM256
2-1/2"	1500#	L2515	SR2515	SJ2515	ST2515	SM2515	SWR2515	WR2515	WJ2515	WT2515	WM2515
3"	150#	L31	SR31	SJ31	ST31	SM31	SWR31	WR31	WJ31	WT31	WM31
3"	300#	L33	SR33	SJ33	ST33	SM33	SWR33	WR33	WJ33	WT33	WM33
3"	600#	L36	SR36	SJ36	ST36	SM36	SWR36	WR36	WJ36	WT36	WM36
3"	900#	L39	SR39	SJ39	ST39	SM39	SWR39	WR39	WJ39	WT39	WM39
3"	1500#	L315	SR315	SJ315	ST315	SM315	SWR315	WR315	WJ315	WT315	WM315
4"	150#	L41	SR41	SJ41	ST41	SM41	SWR41	WR41	WJ41	WQT41	WM41
4"	300#	L43	SR43	SJ43	ST43	SM43	SWR43	WR43	WJ43	WT43	WM43

1. Extruded Outlets are full bore up to a maximum of 2". See Note 1 on Page 47.
2. 1/2" to 2 1/2" flanges use 1500# if 900# is specified.
3. Flat face flanges can be supplied with the (SF or WF) designator. (i.e. for a 1/2" 150# flat face flange, please specify SF51 or WF51)

**Table 4 (continued)**

Nipples: Sch 40 Std.			Plugs:1/2 std.		Threaded Couplings:			Socket Weld Couplings:		
1/2"	Sch.40	N54	1/2"	P5	1/2"	3000#	C53	1/2"	3000#	SC53
1/2"	Sch.80	N58	3/4"	P7	3/4"	3000#	C73	3/4"	3000#	SC73
1/2"	Sch.160	N51	1"	P1	1"	3000#	C13	1"	3000#	SC13
3/4"	Sch.40	N74	2"	P2						
3/4"	Sch.80	N78	3"	P3						
3/4"	Sch.160	N71	4"	P4						
			6"	P6						
1"	Sch.40	N14								
1"	Sch.80	N18								
1"	Sch.160	N11								

Screw-On Caps			Sock-o-lets			Thread -o- lets:		
2"	3000#	S23	1/2"	3000#	S05	1/2"	3000#	T053
2-1/2"	3000#	S253	3/4"	3000#	S07	3/4"	3000#	T073
3"	3000#	S33	1"	3000#	S10	1"	3000#	T103
4"	3000#	S43	1-1/2"	3000#	S15	1-1/2"	3000#	T153
			2"	3000#	S20	2"	3000#	T203
						1/2"	6000#	T056
						3/4"	6000#	T076
						1"	6000#	T106
						1-1/2"	6000#	T156
						2"	6000#	T206

Hex Head Access Connection Codes (NPT Top Mount 510/560 series only)			
1"	3000#	P1	1" MNPT
1-1/2"	3000#	P15	1-1/2" MNPT
2"	3000#	P2	2" MNPT

**Table 5**

<b>Pressure</b>			
<b>To Convert From:</b>	<b>To:</b>	<b>Use this formula:</b>	
Bar	Pounds per Square Inch (psi)	bar	x 14.504 = psi
KiloPascals (kPa)	Pounds per Square Inch (psi)	kPa	x 0.145 = psi
MegaPascals (Mpa)	Pounds per Square Inch (psi)	Mpa	x 145 = psi
Kilograms per cm <sup>2</sup> (kg/cm <sup>2</sup> )	Pounds per Square Inch (psi)	kg/cm <sup>2</sup>	x 14.223 = psi
Pounds per Square Inch (psi)	Bar	psi	÷ 14.504 = bar
Pounds per Square Inch (psi)	Kilo Pascals (kPa)	psi	÷ 0.0145 = kPa
Pounds per Square Inch (psi)	Mega Pascals (Mpa)	psi	÷ 145 = Mpa
Pounds per Square Inch (psi)	Kilograms per cm <sup>2</sup> (kg/cm <sup>2</sup> )	psi	÷ 14.223 = kg/cm <sup>2</sup>
<b>Specific Gravity</b>			
<b>To Convert From:</b>	<b>To:</b>	<b>Use this formula:</b>	
Kilograms per meter <sup>3</sup> (kg/m <sup>3</sup> )	Specific Gravity (SG)	kg/m <sup>3</sup>	x 0.001 = SG
Pounds per foot <sup>3</sup> (lb/ft <sup>3</sup> )	Specific Gravity (SG)	lb/ft <sup>3</sup>	÷ 62.4 = SG
Degrees API	Specific Gravity (SG)	141.5	÷ (API + 131.5) = SG
Specific Gravity (SG)	Kilograms per meter <sup>3</sup> (kg/m <sup>3</sup> )	SG	x 1000 = kg/m <sup>3</sup>
Specific Gravity (SG)	Pounds per foot <sup>3</sup> (lb/ft <sup>3</sup> )	SG	x 62.4 = lb/ft <sup>3</sup>
Specific Gravity (SG)	Degrees API	(141.5 ÷ SG)	- 131.5 = API
<b>Length</b>			
<b>To Convert From:</b>	<b>To:</b>	<b>Use this formula:</b>	
millimeters (mm)	inches (in)	mm	÷ 25.4 = in
meters (m)	feet (ft)	m	x 3.281 = ft
inches (in)	millimeters (mm)	in	x 25.4 = mm
feet (ft)	meters (m)	ft	÷ 3.281 = m
<b>Temperature</b>			
<b>To Convert From:</b>	<b>To:</b>	<b>Use this formula:</b>	
Degrees Fahrenheit (°F)	Degrees Centigrade (°C)	(°F - 32)	÷ 1.8 = °C
Degrees Centigrade (°C)	Degrees Fahrenheit (°F)	(°C x 1.8)	+ 32 = °F
<b>Fluid Flow Rates</b>			
<b>To Convert From:</b>	<b>To:</b>	<b>Use this formula:</b>	
Feet per Second (FPS)	Gallons per Minute (GPM)	FPS x 448.83	x A1 = GPM
Kilograms per Hour (kg/H)	Gallons per Minute (GPM)	(kg/H ÷ kg/m <sup>3</sup> )	x 4.403 = GPM
Meters per Second (m/s)	Gallons per Minute (GPM)	m/s x A2	x 15852 = GPM
Cubic meters per Hour (m <sup>3</sup> /H)	Gallons per Minute (GPM)	m <sup>3</sup> /H	÷ 4.4 = GPM
Gallons per Minuter (GPM)	Feet per Second (FPS)	GPM	÷ (448.83 x A1) = FPS
Gallons per Minuter (GPM)	Kilograms per Hour (kg/H)	GPM x kg/m <sup>3</sup>	÷ 4.403 = kg/H
Gallons per Minuter (GPM)	Meters per Second (m/s)	GPM	÷ (A2 x 15852) = m/s
Gallons per Minuter (GPM)	Cubic meters per Hour (m <sup>3</sup> /H)	GPM	÷ 4.4 = m <sup>3</sup> /H
<b>Variables</b>			
A1 = Area of pipe in square feet (ft <sup>2</sup> )			
A2 = Area of pipe in square meters (m <sup>2</sup> )			
kg/m <sup>3</sup> = Specific gravity in kilograms/cubic meter			

# Contact us

## **ABB Inc.**

18321 Swamp Road  
Prairieville, LA 70769 USA  
Phone: +1 225 673 6100  
Service: +1 225 677 5836  
Fax: +1 225 673 2525  
Service e-mail: [service@us.abb.com](mailto:service@us.abb.com)

**[www.abb.com/level](http://www.abb.com/level)**

## Note

We reserve the right to make technical changes or modify the contents of this document without prior notice. With regard to purchase orders, the agreed particulars shall prevail. ABB does not accept any responsibility whatsoever for potential errors or possible lack of information in this document.

We reserve all rights in this document and in the subject matter and illustrations contained therein. Any reproduction, disclosure to third parties or utilization of its contents - in whole or in parts - is forbidden without prior written consent of ABB.

Copyright© 2012 ABB  
All rights reserved

DS/LS-EN Rev. E 06.2012