

INSTALLATION & MAINTENANCE INSTRUCTIONS

DESCRIPTION

R-series volume boosters are diaphragm operated, air piloted, self-venting regulators. They are designed for general applications that require superior pressure regulation, rapid response to changing flow demands, and excellent stability. Using QB or MM series pressure controllers in conjunction with the R-series volume booster gives a precision pressure control package with high forward and reverse flow capacity. The R-series volume boosters can also be used in vacuum applications where high flow and precise vacuum control is required.

OPERATION

Proportion-Air pilot is used to introduce pressure into the pilot chamber of the R-Series volume booster. This pilot pressure causes the main valve to open introducing a downstream pressure. The downstream pressure acts under the diaphragm of the volume booster and when the pressure under the diaphragm is approximately equal to that acting above the diaphragm, the valve will close and the desired output pressure will be achieved. Should downstream pressure exceed the desired regulated pressure, the excess pressure will cause the diaphragm to move upward, opening the vent hole sealed between valve stem and diaphragm, venting the excess pressure to atmosphere out the exhaust port.

INSTALLATION

Connect primary air to the IN port of the volume booster and to Proportion-Air pilot. Connect pilot output line to pilot port in top of volume booster bonnet. Use 1/4" OD tubing for the pilot output. Plug unused gauge ports. Install a muffler in the EXH port to protect internal parts from contamination and to reduce noise.

Before turning on system pressure, make sure dome pressure is 0 psig. Turn on system pressure and then increase Proportion-Air pilot pressure until the desired pressure downstream of the volume booster is reached.

SPECIFICATIONS

Type	Pilot Operated Relieving Diaphragm
Max Inlet Pressure	450 psig (31bar)
Max Output Pressure	0-300 psig (0-20.6 bar)
Operating Temperature	32-158°F (0-70°C)
Recommended Filtration	40 micron nominal
Forward Flow Capacity	See graphs (FIG.)
Relief Flow Capacity	200 SCFM (5663 SLPM)

MATERIALS

Body, Bonnet, Bottom Plug & Main Valve	Aluminum
Elastomers	Nitrile

PORTS

Main Ports	1-1/2" PTF (R000B) 2" PTF (R000C)
Gauge Ports	1/4"
Pilot Port	1/4"
Exhaust Port	3/4"

- Diaphragm type pilot operated regulator
- High relief flow
- Flows up to 2000 SCFM
- Outlet pressure up to 300 psig
- Vacuum service



MAINTENANCE

DISASSEMBLY INSTRUCTIONS

Shut off inlet pressure to the Proportion-Air pilot and R-Series volume booster. Reduce pressure in pilot, volume booster and connecting pipes to zero.

To access the diaphragm, remove the bolts (10) with a 6mm Allen Wrench. To access main valve assembly, remove bottom plug (24) with a large adjustable wrench.

Clean parts using warm water and soap. Rinse all parts and dry thoroughly. Inspect parts carefully and replace worn or damaged parts.

Lubricate the following parts prior to reassembly: 12, 14, 15, 18, 19, 25, 26, 28 with a good quality O-ring grease (O-rings and surfaces in contact with O-rings).

Hold diaphragm against upper travel limit, then torque screws (10) in a diametrically opposite sequence to 120-130 in-lbs. torque. Tighten bottom plug (24) hand tight.

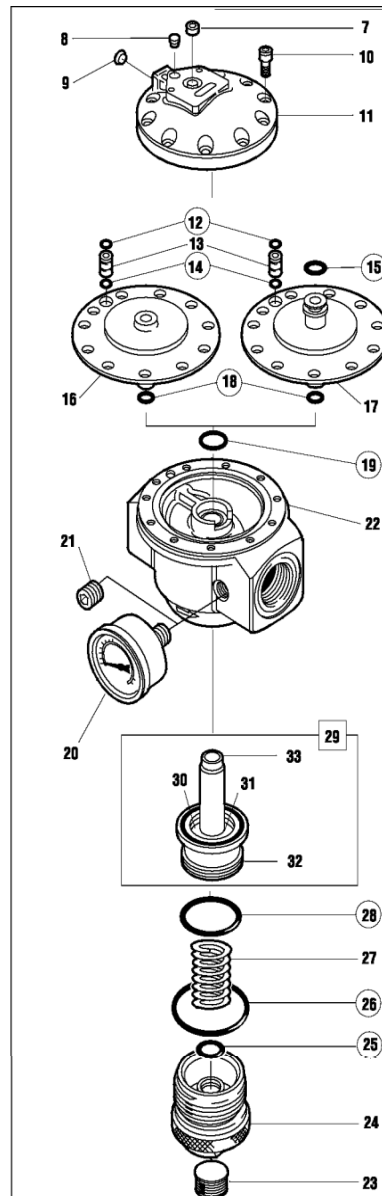

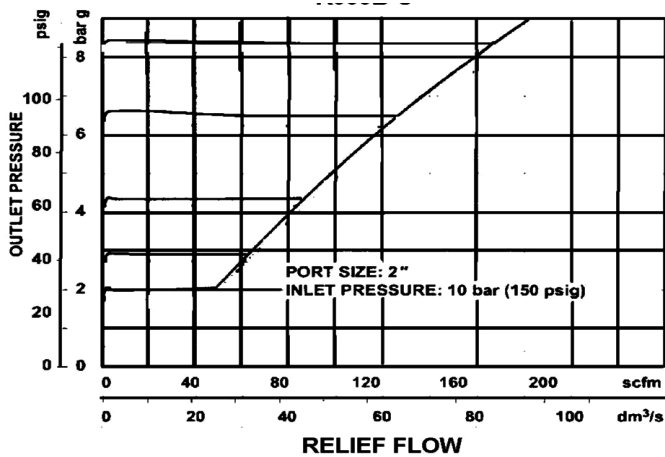
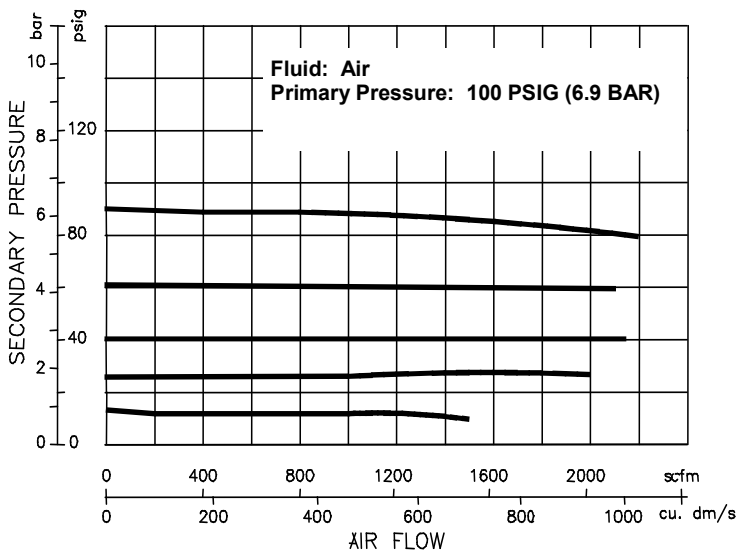

DIMENSIONS in inches (mm)

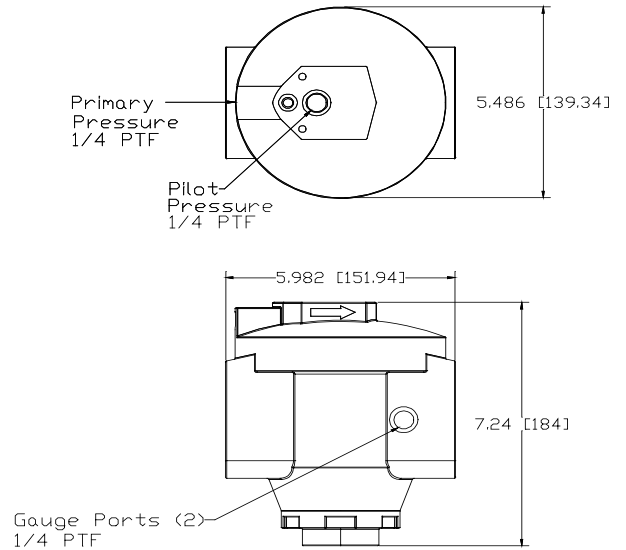

MOUNTING BRACKET (OPTIONAL)

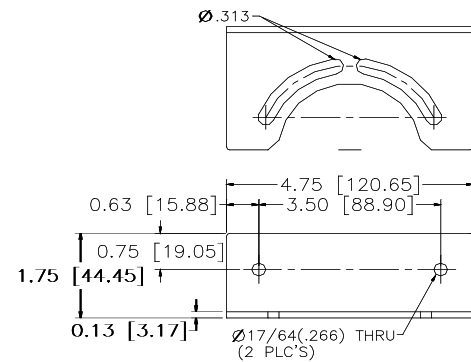

R Series

MAX FLOW 2000 scfm (943 lit/sec)

PRESSURE RANGE 0 to 250 psig (20.7 bar)

PORT SIZES 1-1/2" & 2"

MAX RELIEF FLOW 200 scfm (94 lit/sec)

Example Part Number : **R000 B N NR BR**

YOUR PART NUMBER : **R000**

Section —> 1 2 Options

1 Port Size

B 1-1/2" Port

C 2" Port

2 Thread Type

N NPT

P BSPP

3 Options

NR Non-Relieving

LS Light Spring Installed

BR Bracket Installed

QR Quick Response

REPAIR KITS

Complete Kit

H5890-01

Diaphragm

H5945-61

Main Valve Assembly

H5893-50

Elastomer Kit

H5945-40

MOUNTING BRACKET

BKT-07



Please read all of the following Safety Precautions before installing or operating any Proportion-Air, Inc. equipment or accessories. To confirm safety, be sure to observe 'ISO 4414: Pneumatic Fluid Power - General rules relating to systems' and other safety practices.



Warning

Improper operation could result in serious injury to persons or loss of life!

1. PRODUCT COMPATIBILITY

Proportion-Air, Inc. products and accessories are for use in industrial pneumatic applications with compressed air media. The compatibility of the equipment is the responsibility of the end user. Product performance and safety are the responsibility of the person who determined the compatibility of the system. Also, this person is responsible for continuously reviewing the suitability of the products specified for the system, referencing the latest catalog, installation manual, Safety Precautions and all materials related to the product.

2. EMERGENCY SHUTOFF

Proportion-Air, Inc. products cannot be used as an emergency shutoff. A redundant safety system should be installed in the system to prevent serious injury or loss of life.

3. EXPLOSIVE ATMOSPHERES

Products and equipment should not be used where harmful, corrosive or explosive materials or gases are present. Unless certified, Proportion-Air, Inc. products cannot be used with flammable gases or in hazardous environments.

4. AIR QUALITY

Clean, dry air is not required for Proportion-Air, Inc. products. However, a 40 micron particulate filter is recommended to prevent solid contamination from entering the product.

5. TEMPERATURE

Products should be used with a media and ambient environment inside of the specified temperature range of 32°F to 158°F. Consult factory for expanded temperature ranges.

6. OPERATION

Only trained and certified personnel should operate electronic and pneumatic machinery and equipment. Electronics and pneumatics are very dangerous when handled incorrectly. All industry standard safety guidelines should be observed.

7. SERVICE AND MAINTENANCE

Service and maintenance of machinery and equipment should only be handled by trained and experienced operators. Inspection should only be performed after safety has been confirmed. Ensure all supply pressure has been exhausted and residual energy (compressed gas, springs, gravity, etc.) has been released in the entire system prior to removing equipment for service or maintenance.



Caution

Improper operation could result in serious injury to persons or damages to equipment!

1. PNEUMATIC CONNECTION

All pipes, pneumatic hose and tubing should be free of all contamination, debris and chips prior to installation. Flush pipes with compressed air to remove any loose particles.

2. THREAD SEALANT

To prevent product contamination, thread tape is not recommended. Instead, a non-migrating thread sealant is recommended for installation. Apply sealant a couple threads from the end of the pipe thread to prevent contamination.

3. ELECTRICAL CONNECTION

To prevent electronic damage, all electrical specifications should be reviewed and all electrical connections should be verified prior to operation.

Exemption from Liability

- Proportion-Air, Inc.** is exempted from any damages resulting from any operations not contained within the catalogs and/or instruction manuals and operations outside the range of its product specifications.
- Proportion-Air, Inc.** is exempted from any damage or loss whatsoever caused by malfunctions of its products when combined with other devices or software.
- Proportion-Air, Inc.** and its employees shall be exempted from any damage or loss resulting from earthquakes, fire, third person actions, accidents, intentional or unintentional operator error, product misapplication or irregular operating conditions.
- Proportion-Air, Inc.** and its employees shall be exempted from any damage or loss, either direct or indirect, including consequential damage or loss, claims, proceedings, demands, costs, expenses, judgments, awards, loss of profits or loss of chance and any other liability whatsoever including legal expenses and costs, which may be suffered or incurred, whether in tort (including negligence), contract, breach of statutory duty, equity or otherwise.

Warranty

Proportion-Air, Inc. products are warranted to the original purchaser only against defects in material or workmanship for one (1) year from the date of manufacture. The extent of Proportion-Air's liability under this warranty is limited to repair or replacement of the defective unit at Proportion-Air's option. Proportion-Air shall have no liability under this warranty where improper installation or filtration occurred.

PROPORTION-AIR, INC.

8250 N. 600 West, P.O. Box 218

McCordsville, Indiana 46055

317.335.2602 | info@proportionair.com