

NOTES:

1. **WARNING:** This drawing does not illustrate completely the installation methods required for hazardous locations. Prior to any installation in a Classified Hazardous Location, verify installation methods by the Control Drawing referenced on the product's name tag and national and local codes.
2. The Feed Through Assemblies of the Dual NGCs are made to accommodate sample acquisition for up to 3 lines. Tube additional lines from a Probe to the Feed Through Assemblies as shown on Sheet 4, for each. Each line must have its own Probe and a Sample Conditioning Module at the NGCs.
3. Totalflow strongly suggests a Temperature Compensating, Pressure Regulating Sample Probe be used. Refer to any manufacturer's recommendations supplied with probe. If Sample Probe is to be mounted in a section of pipe where cathodic currents exist, you should install isolators in Sample Tubing between probe and NGC

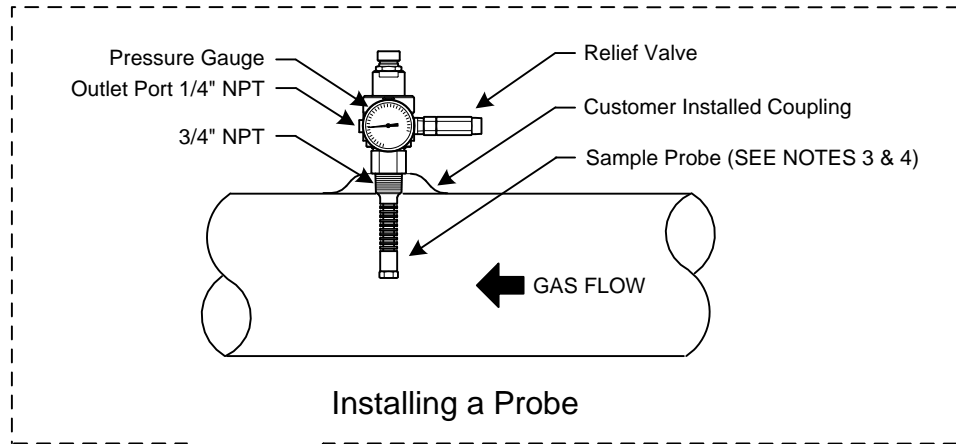

4. API 14.1 recommends using a Strouhal number to determine probe lengths, therefore reducing the effects of resonant vibration. Please refer to API standards for additional information.

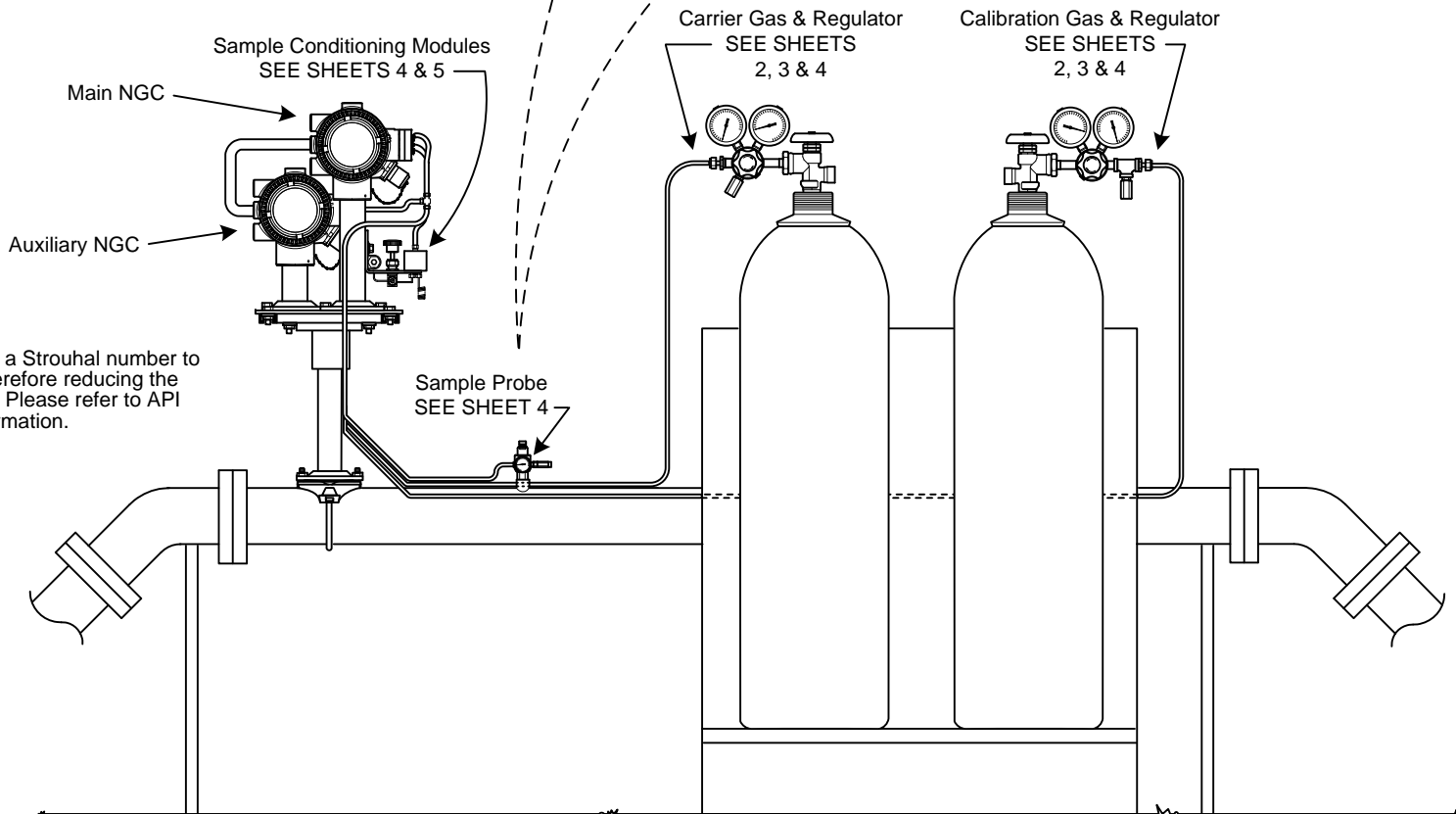

Typical Installation

REF: N/A

	TOTALFLOW Products	ACTION	DOC TYPE	TITLE	DWG NO.	REV	SHEET
		D24130	UD	INSTALLATION OF SAMPLE, CARRIER AND CALIBRATION LINES FOR DUAL NGC	2103086	AD	1 OF 5

NOTES:

1. **WARNING:** This drawing does not illustrate completely the installation methods required for hazardous locations. Prior to any installation in a Classified Hazardous Location, verify installation methods by the Control Drawing referenced on the product's name tag and national and local codes.

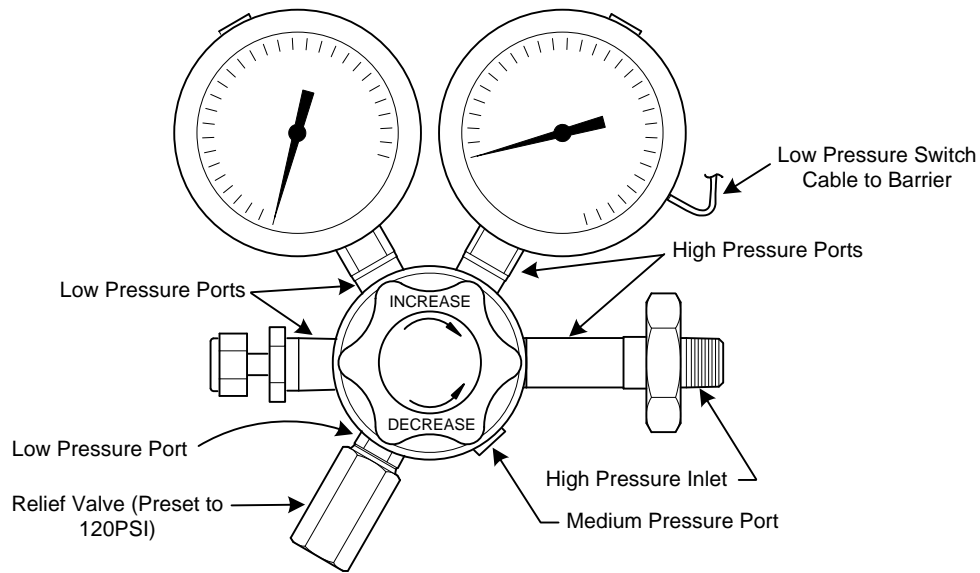

Carrier Regulator

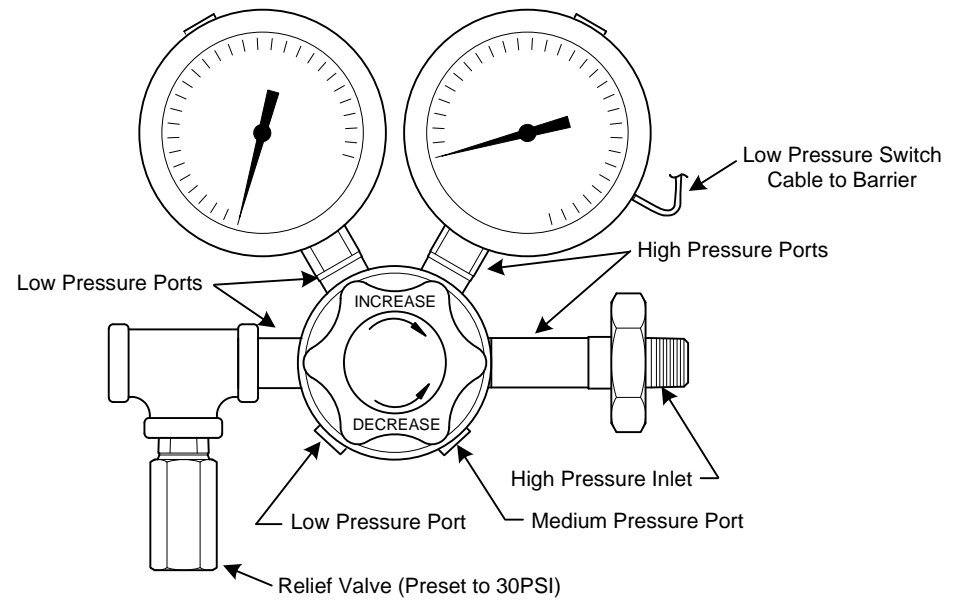

Calibration Regulator

Carrier & Calibration Regulator Details

REF:N/A

ABB TOTALFLOW Products	ACTION	DOC TYPE	TITLE	DWG NO.	REV	SHEET
	D24130	UD	INSTALLATION OF SAMPLE, CARRIER AND CALIBRATION LINES FOR DUAL NGC	2103086	AD	2 OF 5

NOTES:

1. **WARNING:** This drawing does not illustrate completely the installation methods required for hazardous locations. Prior to any installation in a Classified Hazardous Location, verify installation methods by the ControlDrawing referenced on the product's name tag and national and local codes.
2. To access the NGC termination board, remove the enclosure rear cover.

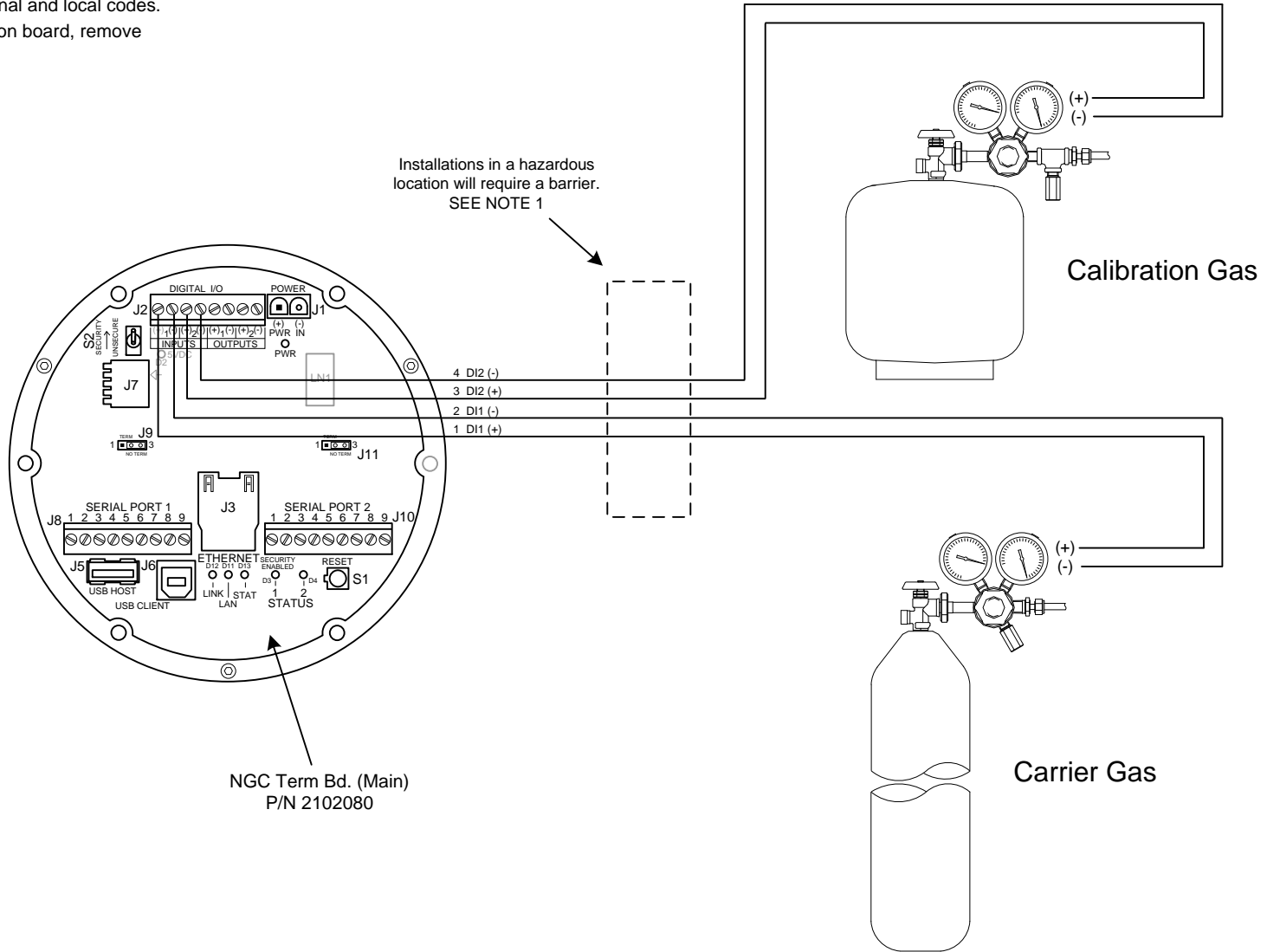

NGC (Main) To Carrier and Calibration Gas Regulators (DI1 & DI2)

REF: N/A

ABB	TOTALFLOW	ACTION	DOC TYPE	TITLE	DWG NO.	REV	SHEET
	Products	D24130	UD	INSTALLATION OF SAMPLE, CARRIER AND CALIBRATION LINES FOR DUAL NGC	2103086	AD	3 OF 5

NOTES:

1. **WARNING:** This drawing does not illustrate completely the installation methods required for hazardous locations. Prior to any installation in a Classified Hazardous Location, verify installation methods by the Control Drawing referenced on the product's name tag and national and local codes.

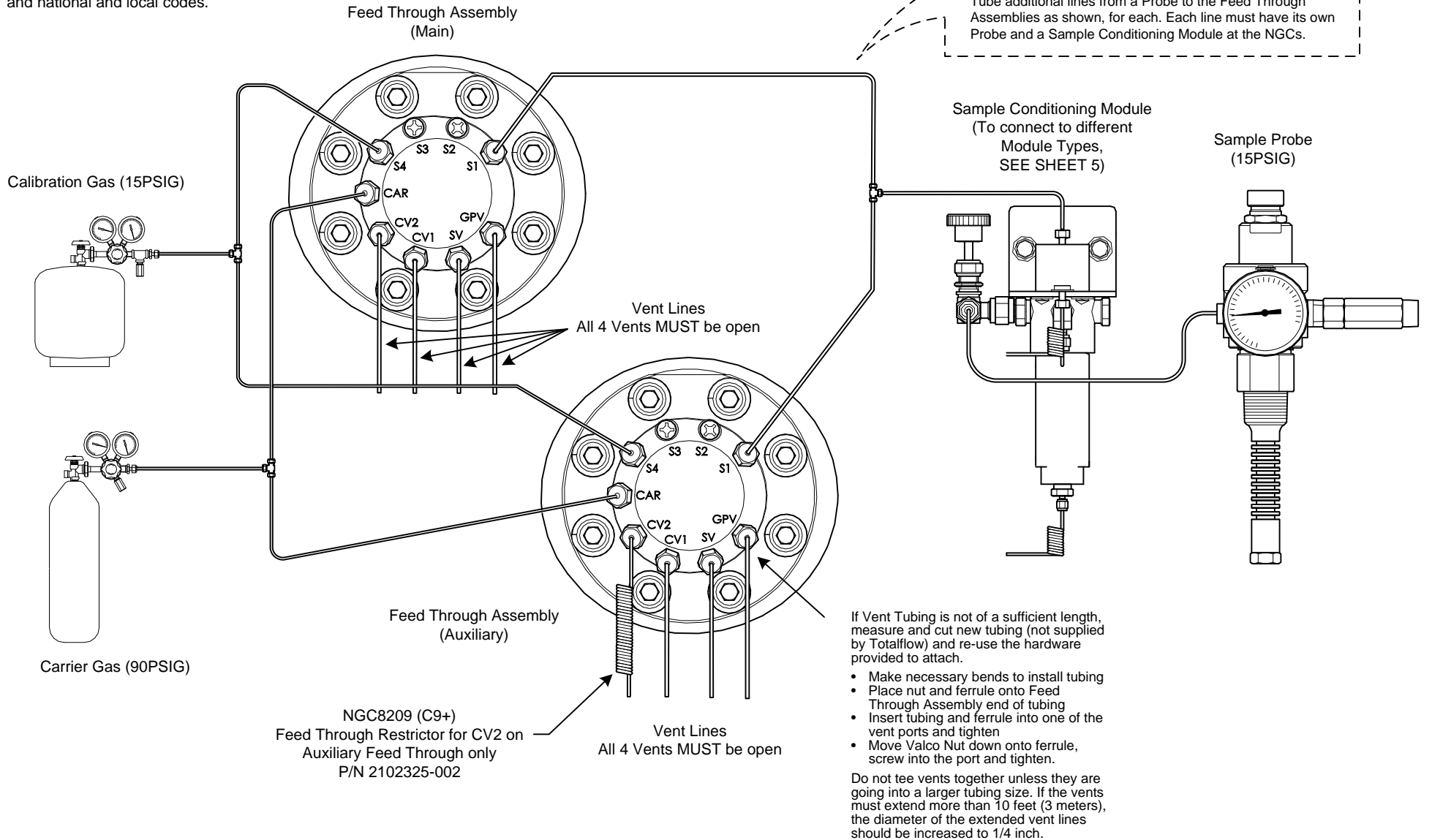

Connecting Lines to Feed Through Assemblies

REF: N/A

	TOTALFLOW Products	ACTION	DOC TYPE	TITLE	DWG NO.	REV	SHEET
		D24130	UD	INSTALLATION OF SAMPLE, CARRIER AND CALIBRATION LINES FOR DUAL NGC	2103086	AD	4 OF 5

NOTES:

- WARNING:** This drawing does not illustrate completely the installation methods required for hazardous locations. Prior to any installation in a Classified Hazardous Location, verify installation methods by the Control Drawing referenced on the product's name tag and national and local codes.

Descriptions & Connections to Available Sample Conditioners

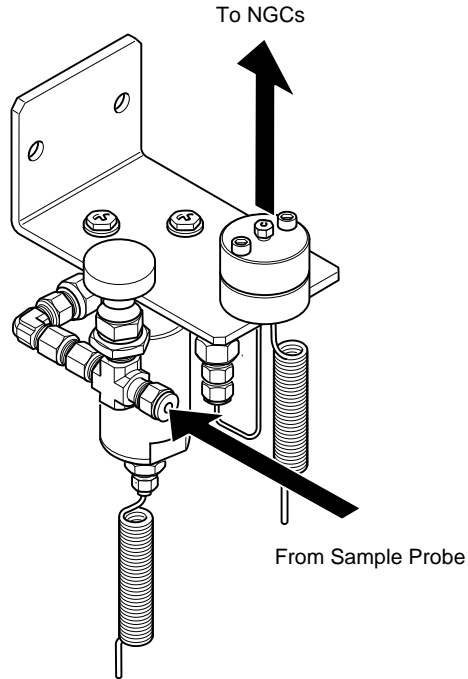

Type 3

Totalflow P/N: 2102024-001

Install this option if distance to Sample Probe is from up to, but less than 450' (137 meters).

This system is for stable gas and other solid contaminants, plus possible liquid contamination such as glycol, compressor oil or water.

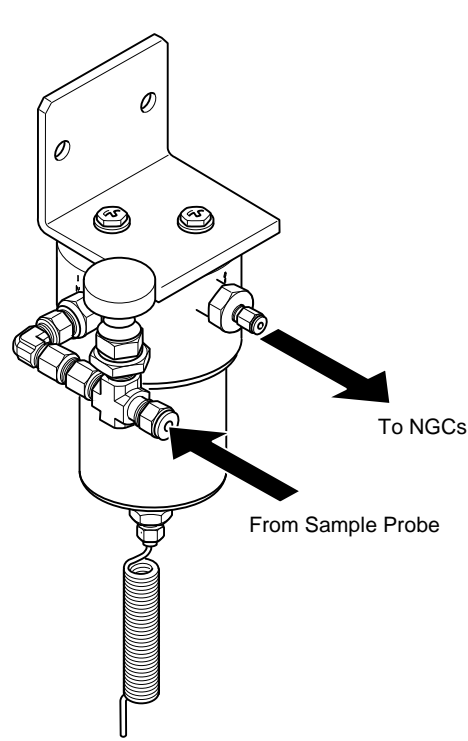

Type 4

Totalflow P/N: 2102494-001

Install this option if distance to Sample Probe is from up to, but less than 450' (137 meters).

This system is for gas samples with heavy solids and liquid contamination. If liquid breaks through the membrane filter, sample flow will be blocked to the analyzer. Once liquids are no longer present, sample flow will be resumed automatically.

The entire sampling system, including the Sample Probe, must be kept at a constant temperature if ambient temperature is less than the Dew Point.

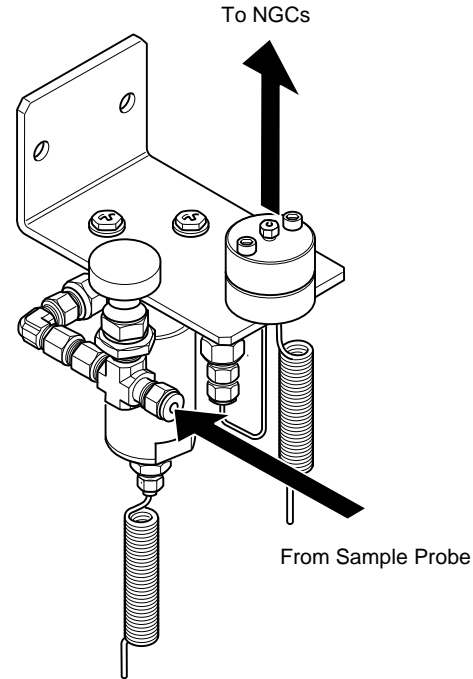

Type 3

Totalflow P/N: 2103380-001

Install this option if distance to Sample Probe is from up to, but less than 450' (137 meters).

This system is an H²S version of the Type 3.

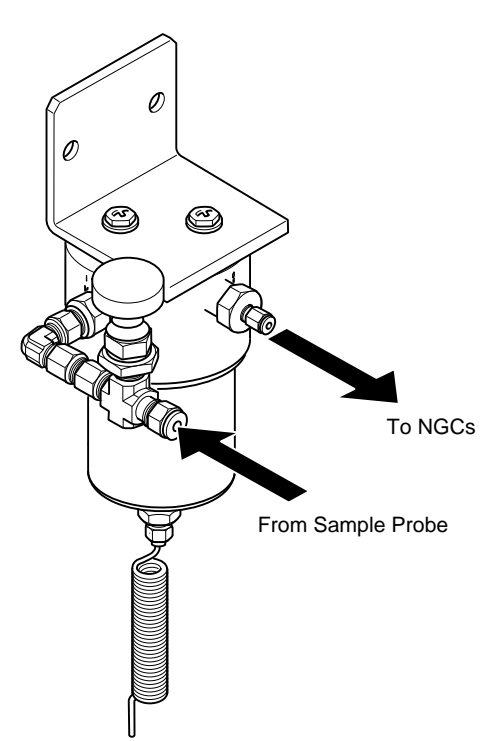

Type 4

Totalflow P/N: 2103381-001

Install this option if distance to Sample Probe is from up to, but less than 450' (137 meters).

This system is an H²S version of the Type 4.

REF: N/A

ABB TOTALFLOW Products	ACTION	DOC TYPE	TITLE	DWG NO.	REV	SHEET
	D24130	UD	INSTALLATION OF SAMPLE, CARRIER AND CALIBRATION LINES FOR DUAL NGC	2103086	AD	5 OF 5