

# VOLU-flo/OAM II Transmitter

Version 1.2

Differential Pressure Airflow & Temperature  
Measurement System



Installation, Operation and Maintenance Manual



[www.airmonitor.com](http://www.airmonitor.com) • 1-800-AIRFLOW

## Regarding this Manual

- This manual should be passed on to the end user.
- Before use, read this manual thoroughly to comprehend its contents.
- The contents of this manual may be changed without prior notice.
- All rights reserved. No part of this manual may be reproduced in any form without Air Monitor's written permission.
- Air Monitor makes no warranty of any kind with regard to this material, including, but not limited to, implied warranties of merchantability and suitability for a particular purpose.
- All reasonable effort has been made to ensure the accuracy of the contents of this manual. However, if any errors are found, please inform Air Monitor.
- Air Monitor assumes no responsibilities for this product except as stated in the warranty. If the customer or any third party is harmed by the use of this product, Air Monitor assumes no responsibility for any such harm owing to any defects in the product which were not predictable, or for any indirect damages.

## Safety Precautions

The following general safety precautions must be observed during all phases of installation, operation, service, and repair of this product. Failure to comply with these precautions or with specific WARNINGS given elsewhere in this manual violates safety standards of design, manufacture, and intended use of the product. Air Monitor Corporation assumes no liability for the customer's failure to comply with these requirements. If this product is used in a manner not specified in this manual, the protection provided by this product may be impaired.

The following symbols are used in this manual:



### WARNING

Messages identified as "Warning" contain information regarding the personal safety of individuals involved in the installation, operation or service of this product.



### CAUTION

Messages identified as "Caution" contain information regarding potential damage to the product or other ancillary products.



### IMPORTANT NOTE

Messages identified as "Important Note" contain information critical to the proper operation of the product.

## TABLE OF CONTENTS

<b>1.0</b>	<b>GENERAL INFORMATION .....</b>	<b>4</b>
1.1	PURPOSE OF THIS GUIDE.....	4
1.2	TYPICAL METER INSTALLATION .....	4
1.3	SPECIFICATIONS.....	6
1.4	CHECKING THAT YOU RECEIVED EVERYTHING .....	7
1.5	WORKING ENVIRONMENT.....	7
1.6	SERIAL NUMBER.....	7
<b>2.0</b>	<b>INSTALLATION .....</b>	<b>8</b>
2.1	SITE SELECTION.....	8
2.2	ENCLOSURE INSTALLATION.....	9
2.3	AIRFLOW SENSORS.....	10
2.4	AIRFLOW SENSOR INSTALLATION .....	11
2.5	AIRFLOW SENSOR INSTALLATION DETAIL .....	12
2.6	AIRFLOW SENSOR PROCESS CONNECTIONS .....	14
2.7	POWER/SIGNAL CONNECTIONS.....	15
<b>3.0</b>	<b>OPERATION .....</b>	<b>16</b>
3.1	OPERATING MODES .....	16
3.2	DISPLAY OPTIONS BASED ON OPERATING MODE.....	16
3.3	STATUS BAR .....	17
<b>4.0</b>	<b>PROGRAMMING MENU .....</b>	<b>17</b>
4.1	MAIN MENU.....	18
4.2	FLOW SETTINGS (LOW/EXT/SPLIT/DUAL) .....	18
4.3	FLOW CONFIGURATION (LOW/EXT).....	19
4.4	DISPLAY CONFIGURATIN (LOW/EXT/SPLIT/DUAL).....	21
4.5	ANALOG OUTPUT CONFIGURATION .....	21
4.6	FILTER AND LOCKDOWN SETTINGS .....	22
4.7	TRANSDUCER CONFIGURATION .....	23
4.8	NETWORK CONFIGURATION.....	23
4.9	FIELD CHARACTERIZATION .....	24
5.0	SERVICE MENU.....	25
5.1	PASSWORD.....	25
5.2	AUTOZERO INTERVAL.....	25
5.3	CALIBRATE TRANSDUCERS.....	25
5.4	ANALOG OUTPUT CALIBRATION .....	26
5.5	SET CUSTOM ID.....	26
5.6	FACTORY SETTINGS.....	27
5.7	PRODUCT INFORMATION .....	27
5.8	AUTOZERO AND ANALOG OUTPUT TEST.....	27
<b>6.0</b>	<b>COMMUNICATIONS .....</b>	<b>28</b>
<b>7.0</b>	<b>MAINTENANCE.....</b>	<b>32</b>
<b>8.0</b>	<b>TROUBLESHOOTING .....</b>	<b>32</b>
<b>9.0</b>	<b>WARRANTY INFORMATION.....</b>	<b>33</b>

## SECTION 1.0 GENERAL INFORMATION

Thank you for purchasing the OAM II Outdoor Airflow Measurement System. As our valued customer, Air Monitor's commitment to you is to provide quality service and support while continuing to offer you accurate, reliable products to meet your flow measurement needs.

### 1.1 PURPOSE OF THIS MANUAL

This manual provides information regarding the installation, operation and maintenance of your differential pressure airflow measurement system. This is not an electrical or HVAC trade manual. This manual is the basic reference tool for the OAM II transmitter, including its mains power connection and associated signal inputs and outputs. The complete system consists of the transmitter and associated airflow and temperature sensors. Please refer to supplemental documents for additional information.

### 1.2 TYPICAL AIRFLOW MEASUREMENT SYSTEM INSTALLATIONS

Air Monitor's OAM II Outdoor Airflow Measurement system has been specifically designed to accurately measure airflow by measuring the pressure drop across a fixed inlet resistance such as a set of louvers or a layer of expanded metal. Temperature is also measured via a separate sensor. The measured pressure drop and temperature are converted to actual air flow readings utilizing proprietary algorithms that provide density compensation and signal conditioning.

The OAM II can be used with most single, dual, and split inlets found on air handlers and built-up systems. Depicted below are the most commonly encountered inlet configurations.

For clarity, the examples below are only shown with only one airflow sensor at each location. With larger inlets or multiple inlets to one air handler, multiple sensors would be connected in parallel using manifolds.

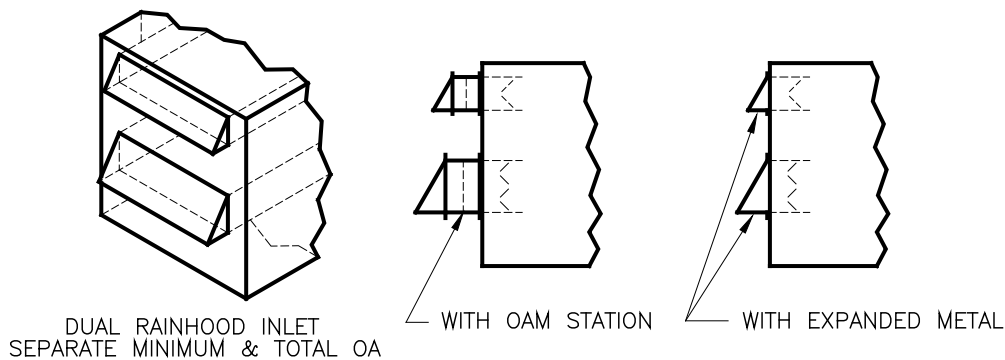

The example above illustrates a single OA inlet. The OAM II would be configured for low flow or extended mode operation for this application.

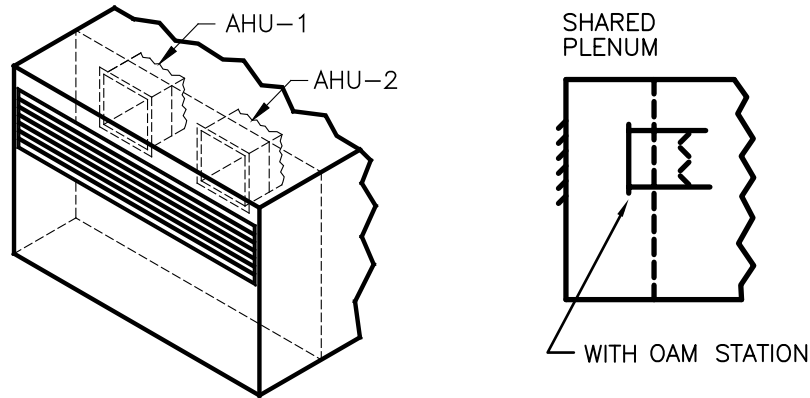

The example above illustrates a dual OA inlet (two inlets providing outside air to separate air handlers). In this application, the VOLU-flo/OAM II would be configured for dual mode operation. Separate flow readings will be reported for each channel in this mode.

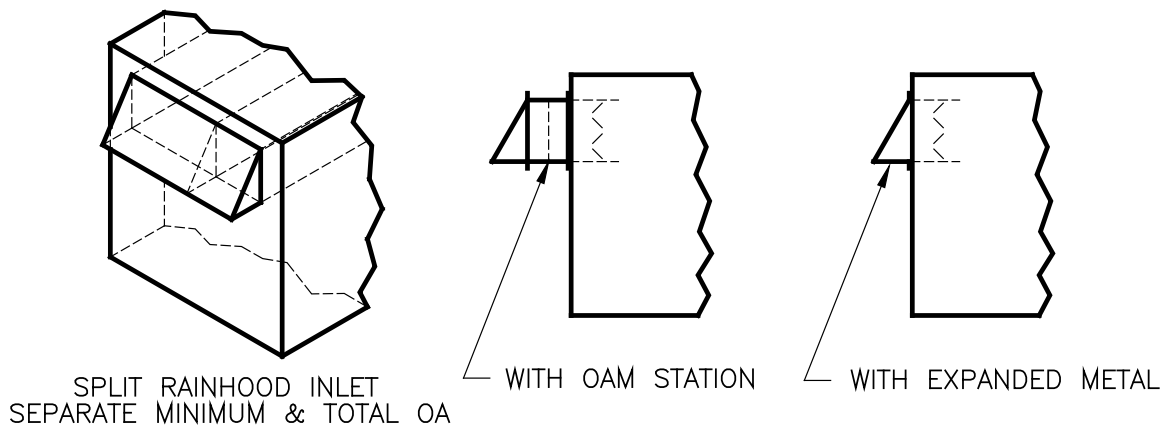

The example above illustrates a split OA inlet. Two inlets separately provide minimum and economizer outside air flow to a single air handler. In this application, the VOLU-flo/OAM II would be configured for split min/max mode operation. Separate flow readings will be reported for each channel in this mode.

## 1.3 SPECIFICATIONS

### SENSING METHOD

Differential pressure is measured across a fixed inlet resistance along with temperature. Sensor readings are used to calculate and report velocity, volumetric flow and temperature data. The fixed inlet resistance must produce at least 0.06" w.c. pressure drop at 600 FPM face velocity.

### MEASUREMENT MODES

**Low Flow Mode:** provides a single differential pressure signal connection

**Extended Mode:** provides a single differential pressure signal connection operating over an extended flow range

**Min/Max (Split) Mode:** provides two differential pressure signal connections, one for the minimum OA inlet, and the other for the maximum OA inlet.

**Dual Mode:** provides separate air flow measurement channels for OA feeding two separate air handlers.

### ACCURACY

#### Airflow

±5% of actual airflow over the specified operating range above 150 FPM. Requires an optional enclosure heater to maintain accuracy when operating at ambient temperatures below 32 °F.

#### Temperature

±2° F from -50 to 120 °F

### OVERALL FLOW RANGE (≥ 100 FPM)

**Low flow operating mode:** 6:1 turn-down

**Extended operating mode:** up to 24:1 turn-down

**Min/Max (Split) operating mode:** 6:1 turn-down for each channel

**Dual operating mode:** 4:1 turn-down for each channel

**AVAILABLE TRANSDUCERS** (max. pressure in inches w.c.) 0.1, 0.25, 0.5, 1.0, 2.0, 5.0 and 10

### AVAILABLE SENSOR TYPES

#### Uni-sensor

316 stainless steel combination reference and inlet airflow pressure sensors.

#### Temperature

316 stainless steel 3-wire 100 Ohm Platinum RTD with ¼" NPT mounting hardware

### ENCLOSURE

**Standard:** NEMA 1 aluminum with hinged cover

**Optional:** NEMA 4 with display window and heater

### AIRFLOW SENSOR CONNECTIONS

**Channel 1 transducer:** 316 stainless steel ¼" NPT compression fittings used for low flow, Extended or channel 1 Dual mode or as the minimum pressure port for Min/Max (Split) mode

**Channel 2 transducer:** 316 stainless steel ¼" NPT compression fittings for channel 2 Dual mode or as the maximum pressure port Split Min/Max mode  
**Temperature:** 3-wire RTD terminal block connections

### TEMPERATURE LIMITS

**Standard operating range:** +32 to 120 °F

**Extended operating range:** -40 to 120 °F (requires optional NEMA4 enclosure heater)

**Storage temperature range:** -20 to 180 °F

### POWER SUPPLY REQUIREMENTS

24VAC (20-32VAC RMS) or 24VDC (20-40VDC)

#### Power Consumption

**Standard:** 18VA @ 24VAC; 13W @ 24VDC

**With heater:** 40VA @ 24VAC; 35W @ 24VDC

### DISPLAY

3.5" diagonal color graphic LCD with field programmable menu driven user interface accessed via four button membrane keypad.

### PROGRAMMING

Factory programmed for specific application. Field programming available through the user interface/display.

### MEMORY

Nonvolatile FLASH memory retains all program parameters in the event of power loss.

### ANALOG OUTPUTS

**Three analog outputs are provided:** Depending on the operating mode, they can report flow, temperature and/or differential pressure.

**Field configurable via user interface/display as:** 4-20mA, 0-10 VDC or 0-5VDC

**COMMUNICATION PROTOCOLS** (Field configurable via user interface/display)

BACnet MS/TP (Default)

MODBUS RTU

### NETWORK CONFIGURATION & ADDRESSING

RS485 unit load: ½

**Recommended maximum number of devices per segment:** 32

**Baud Rates:** 9600, 19200, 38400, 57600, 76800, or 115200 (Default: 38400)

**Device Address Range:** 1 – 255 (1 - 247 MODBUS) (Default: 1)

**BACnet Device Instance Range:** 1 – 4,194,303 (Default 1)

**BACnet Max Master Range:** 1 – 127 (Default 127)

**MODBUS Parity:** None, Even, Odd (Default: Even)

### APPROVALS

FCC Part 15 Subpart B, Class A Device

## **1.4 CHECKING THAT YOU RECEIVED EVERYTHING**

Carefully open the VOLU-flo/OAM II shipping container(s) and remove all equipment. Inspect equipment for any damage. If damaged, contact Air Monitor and your freight company. Verify that the following items have been shipped:

- 1 OAM transmitter
- 1 temperature probe with mounting hardware  
(Packed inside enclosure or part of OAM II Station)
- 1 VOLU-flo/OAM II I/O & M manual
- 1 Factory Set-Up Information Sheet

Additional items included with the shipment may contain the following:

- 1 or more pre-fabricated OAM Airflow Stations
- 1 or more uni-sensors, including mounting hardware

## **1.5 WORKING ENVIRONMENT**

The OAM II with transmitter NEMA 1 enclosure was designed for installation and use in indoor commercial/residential environments that are free of condensing moisture, temperature extremes and excessive vibration. Do not expose to direct sunlight. The operating ambient air temperature range is 32° to 120° F.

The OAM II transmitter with optional NEMA 4 enclosure was designed for installation and use indoors or outdoors in commercial/residential environments, that are free of excessive vibration. Avoid exposure to direct sunlight. The operating ambient air temperature range is 32° to 120° F. When provided with an optional heater, the operating ambient air temperature range is -40° to 120° F.

The electrical supply should be relatively clean, free of high frequency noise, large voltage transients, and protected from power surges and brown outs. Avoid installation locations that are in close proximity to strong sources of electrical interference.

## **1.6 SERIAL NUMBER**

The serial number of your OAM II transmitter is located outside of the enclosure. The serial number is a unique identifier for your product. Please have it available when contacting Air Monitor for assistance regarding your product.

## SECTION 2.0: INSTALLATION

The OAM II Airflow Measurement System should be installed by experienced HVAC technicians and others with related knowledge and experience with air flow systems. Air Monitor support personnel are available to assist with technical recommendations and to provide guidance by telephone and/or e-mail. On-site field engineering, installation, and service are also available at an additional cost.

The installer should use good trade practices and must adhere to all state and local building codes.

Each OAM II is individually calibrated, configured and programmed using customer specific application data. Configuration and programming parameters are recorded on the Factory Set-Up Information Sheet, provided with the unit. Review this information and verify that the OAM II setup is correct for your application. If any problems or discrepancies are detected, contact Air Monitor's Customer Service Department at 1-800-AIRFLOW prior to proceeding.

### 2.1 SITE SELECTION

- Careful attention to the site selection for the system components will help the installers with the initial installation, reduce start-up problems, and make future maintenance easier. For example, do not install the OAM II transmitter where it will be difficult for personnel to perform periodic maintenance. When selecting a site for mounting the system components, consider the criteria under Section 1.5: WORKING ENVIRONMENT, as well as the following:

- **OAM II enclosure**

The standard NEMA1 transmitter enclosure is intended for indoor installations in non-condensing environments.

The optional NEMA4 transmitter is suitable for outdoor installations. Avoid mounting the enclosure in direct sunlight.

Find an easily accessible mounting location near the air handler to minimize sensor tubing lengths. Mounting the enclosure slightly higher than the sensors will reduce the risk of any water (from condensation) migrating into the enclosure. If this cannot be done, provisions for drip legs should be installed at the lowest point in the sensing lines.

- **Airflow sensors**

Each OAM II is factory configured for one of four operating modes. Each mode is intended for use in specific applications. In all cases, uni-sensors should be installed at or near the center of the inlet. When using multiple sensors on a single inlet, equidistant spacing is required.

- **Temperature sensors**

A single RTD temperature sensor is installed with each OAM II. This sensor provides ambient air temperature for density correction calculations. When the OAM II is provided with a NEMA1 enclosure, the sensor may be installed in the air flow stream or outside the air handler in a shaded area. When provided with the NEMA4 enclosure, the temperature sensor is mounted to the bottom of the enclosure in a shaded area. When ordered with an OAM II Station, the sensor will be installed on the station. In all cases, do not mount this sensor in direct sunlight.



## 2.2 ENCLOSURE INSTALLATION

Find an easily accessible location where electrical connections can be made and display readings can be taken from the floor level.

Use four screws for mounting the enclosure. The mounting surface must be structurally sound and capable of withstanding a minimum weight of 40lbs (18kg). Use the following screws for mounting.

For NEMA1 enclosure:

- (4) Machine screws - #8-32 x 1.5"
- (4) Wood screws - #8 x 1.5"
- (4) Concrete screws - 3/16" x 1.5"

For NEMA4 enclosure:

- (4) Machine screws - HHMS .25-20 x 1.5"
- (4) Wood screws - FHLS .25 x 1.5"
- (4) Concrete screws - HHCS .25 x 1.5"

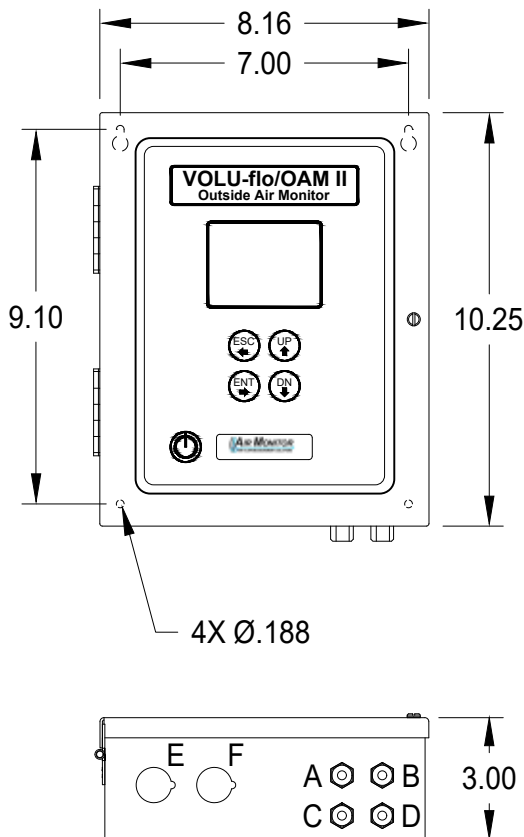

**NEMA 1**

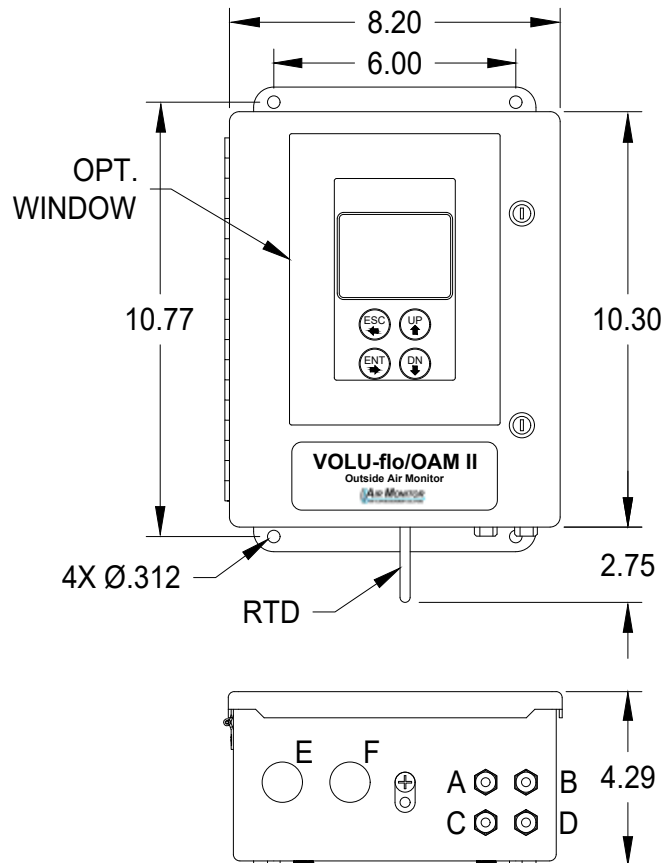

**NEMA 4**

## 2.3 AIRFLOW SENSORS

Air Monitor provides airflow sensors in pre-fabricated airflow stations and as separate Uni-sensors as shown below.

### OAM II Airflow Station (shown with a single Uni-sensor)

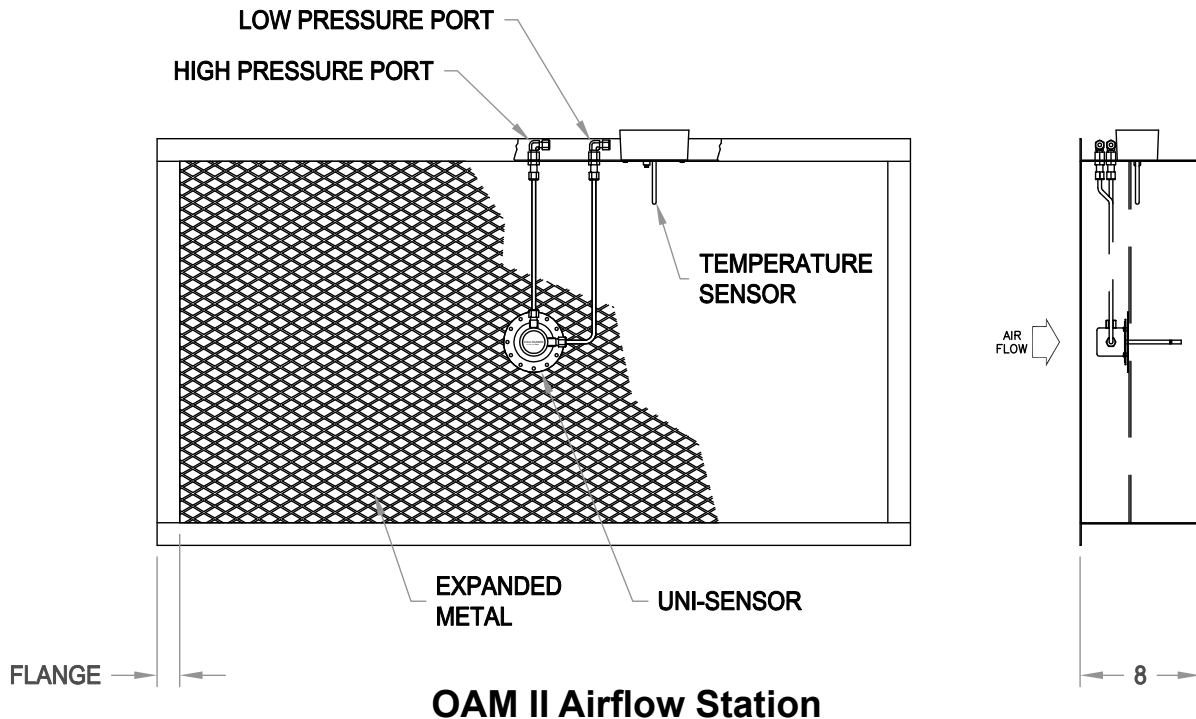

OAM II stations are built to order and provided fully assembled. The number of sensors provided varies based on the size and shape of the station. When multiple OAM II stations are provided for a single system, only one RTD will be included.

### DIMENSIONAL SPECIFICATIONS - UNI-SENSOR

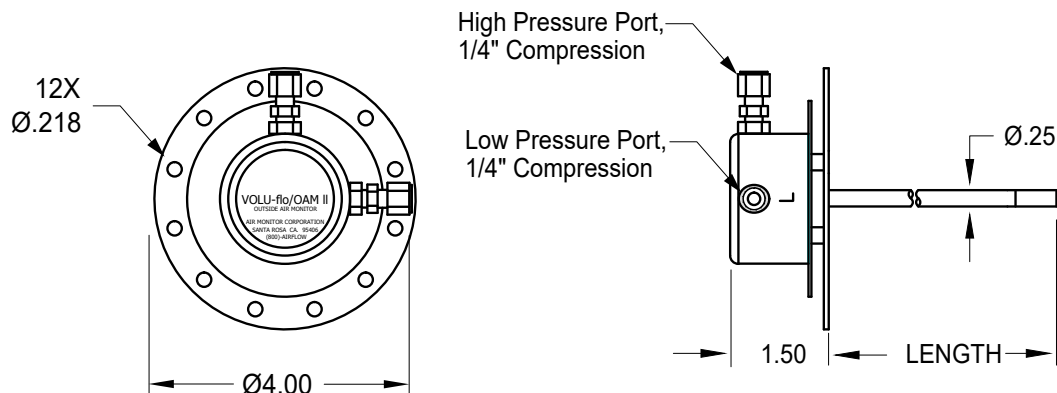

### Uni-sensor

Uni-sensors combine the outside reference (high pressure) sensor and the inlet airflow (low pressure) sensor into one assembly. They are provided with probe lengths that match the clearance requirements of the inlet where they will be installed.

## 2.4 AIRFLOW SENSOR INSTALLATION

The following information details the installation requirements for the airflow sensors. Depending on what was ordered with your OAM II system, it will be necessary to install one or more pre-fabricated OAM II airflow stations or uni-sensors.

When installing a single uni-sensor at each inlet, it should be located as close to the center of the opening as possible.



### IMPORTANT NOTE

Built-up systems should always use flattened galvanized or stainless steel expanded metal with the follow dimensions that follow: 63% open area, 0.05" thickness, 0.50" SWD x 1.25" LWD x 0.096" strand width.

Air Monitor recommends that signal tubing between the transmitter enclosure and all sensors be 1/4" OD stainless steel or copper. Use tees or manifolds when combining multiple sensor signals at the transmitter input. UV resistant flexible plastic tubing specifically designed for outdoor use, such as Tygon R-3400 or equivalent, may also be used.



### CAUTION

Flexible plastic signal tubing used in outdoor applications must be resistant to weathering and the effects of UV exposure.

The following restrictions must be observed to ensure an accurate air flow measurement.

#### Louvered inlets:

- There must be a minimum clearance of 4" between the louver and the edge of the damper blades when damper is wide open.
- The recommended distance between tip of the OAM uni-sensor and the edge of the 100% open damper blade should be at least 2".
- The louver depth will dictate the length of the uni-sensor probe (louver depth + 2").

#### Rain Hood Inlets:

- In order to use an existing screen, it must meet the specified pressure drop requirement of 0.06 inches w.c. at 600 FPM.

#### Plenum Inlets:

- When installing an OAM station directly on an AHU's OA inlet that has damper blades extending outside the damper casing, there must be a minimum clearance of 4" between the screen and the edge of the damper blades when damper is wide open.
- The distance between tip of the OAM uni-sensor and the edge of the 100% open damper blade should be at least 2".

#### Ducted Inlets:

- Airflow stations installed in ducts should be located such that there is no interference upstream or downstream of the station that would intrude into the OAM station casing or into the area where the Uni-sensor is installed.

#### Multiple Inlets: (OAM II transmitter in standard or extended mode)

- The area of each inlet must be the same and inlet dampers must operate in unison.
- Uni-sensors must be installed on each inlet and then connected via manifolds to provide averaged sensor signals to the transmitter.

### Inlets with an Aspect Ratio > 6:1

- Inlets with an aspect ratio > 6:1 require the use of multiple uni-sensors spaced at equidistant intervals. For example: A 2' x 30' louvered inlet has aspect ratio of 15:1. Use three equally spaced sensors serving 2' x 10' areas, to reduce the aspect ratio to 5:1 for each sensor.
- Uni-sensors must be connected via manifolds to provide averaged sensor signals to the transmitter.

### Very Large Inlets:

- Inlets with an area > 30 ft<sup>2</sup> require the use of multiple uni-sensors spaced at equidistant intervals. For example: A 7' x 12' inlet would require three sensors with each sensor covering a 7' x 4' area. Uni-sensors must be connected via manifolds to provide averaged sensor signals to the transmitter.

## 2.5 AIRFLOW SENSOR INSTALLATION DETAIL

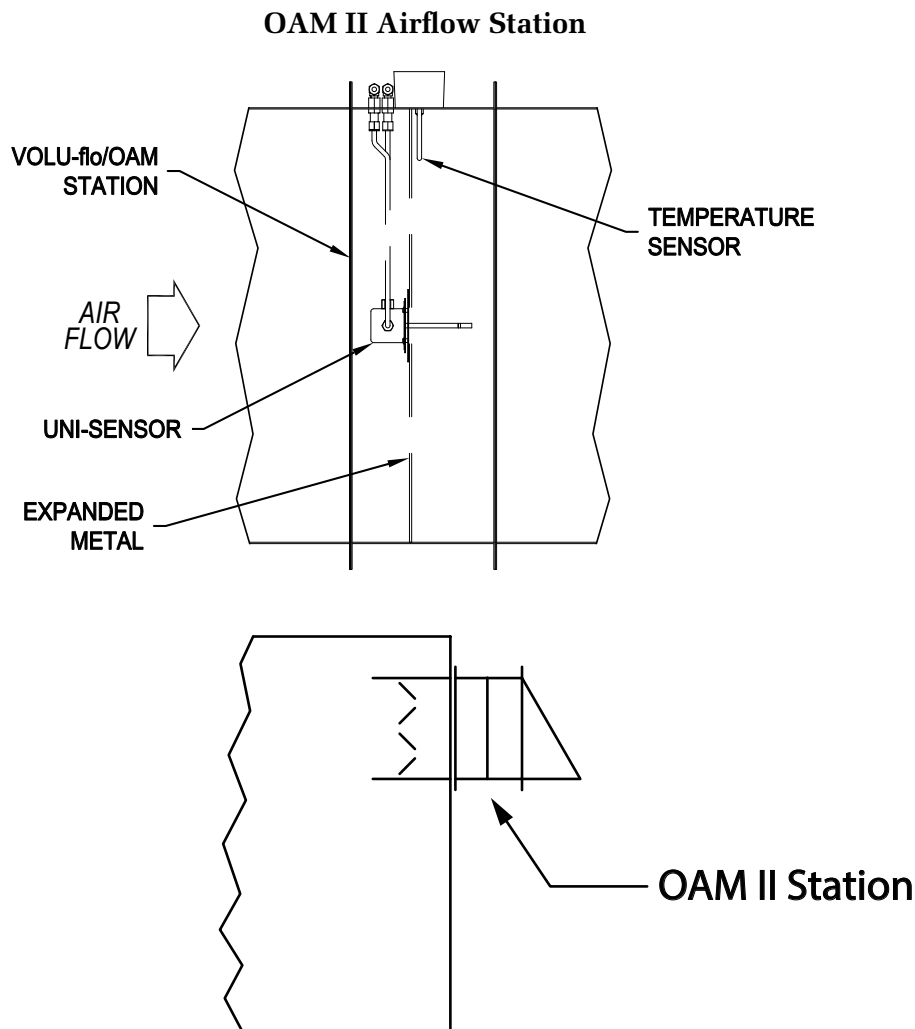

Pre-fabricated OAM airflow stations are built to order and delivered ready for installation in ductwork or attached to an inlet using hardware provided by the installer.

NOTE: A temperature sensor is built into one of the OAM stations.

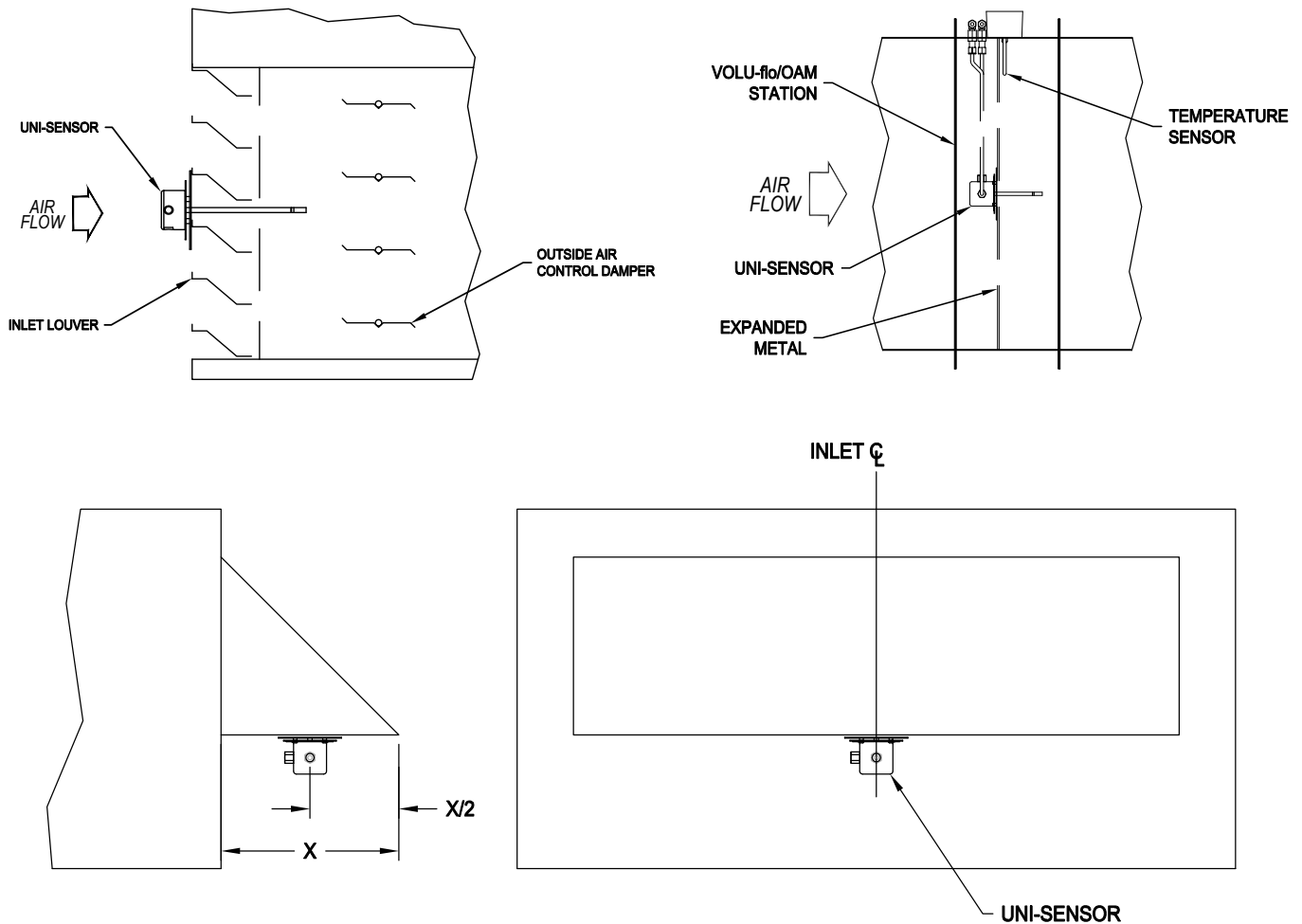

### Uni-sensors

Uni-sensors are installed in ductwork or attached to an inlet using the hardware provided. Air Monitor recommends that signal tubing between the transmitter enclosure and all sensors be 1/4" OD stainless steel or copper. UV resistant flexible plastic tubing specifically designed for outdoor use, such as Tygon R-3400 or equivalent, may also be used.



#### CAUTION

Flexible plastic signal tubing used in outdoor applications must be resistant to weathering and the effects of UV exposure.



#### IMPORTANT NOTE

Built-up systems should always use flattened galvanized or stainless steel expanded metal with the dimensions that follow: 63% open area, 0.05" thickness, 0.50" SWD x 1.25" LWD x 0.096" strand width.

## Temperature sensor

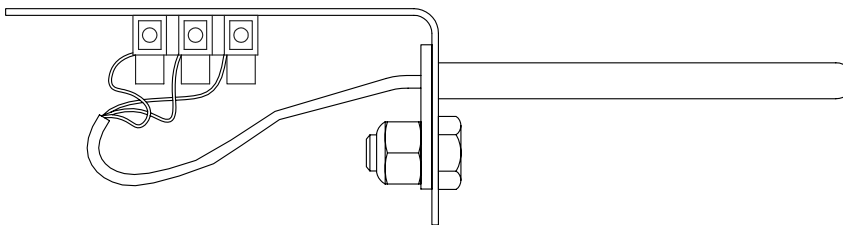

### Installation with the NEMA1 OAM II enclosure.

- Remove the RTD temperature probe from the enclosure (taped in bag at bottom).
- Locate a convenient mounting location inside the air handler to mount the probe.
- Use the two supplied sheet metal screws to mount the probe.

### Installation with the NEMA4 OAM II enclosure.

- Remove the RTD temperature probe from the enclosure (taped in bag at bottom).
- Remove the compression nut from the unmarked bulkhead fitting at the bottom of the enclosure.
- From outside the enclosure, slip the probe, wires first, into the fitting until it bottoms out.
- Slip compression nut over the probe and thread onto fitting.
- Tighten nut one-half turn past finger tight.

## 2.6 AIRFLOW SENSOR PROCESS CONNECTIONS

Air Monitor recommends that signal tubing between the transmitter enclosure and all sensors be 1/4" OD stainless steel or copper. Use tees or manifolds when combining multiple sensor signals at the transmitter input. UV resistant flexible plastic tubing specifically designed for outdoor use, such as Tygon R-3400 or equivalent, may also be used.



### CAUTION

Flexible plastic signal tubing used in outdoor applications must be resistant to weathering and the effects of UV exposure.



### CAUTION

When installing or removing signal tubing from either the enclosure or the sensors, a wrench should be used on the bulkhead nut to prevent turning.

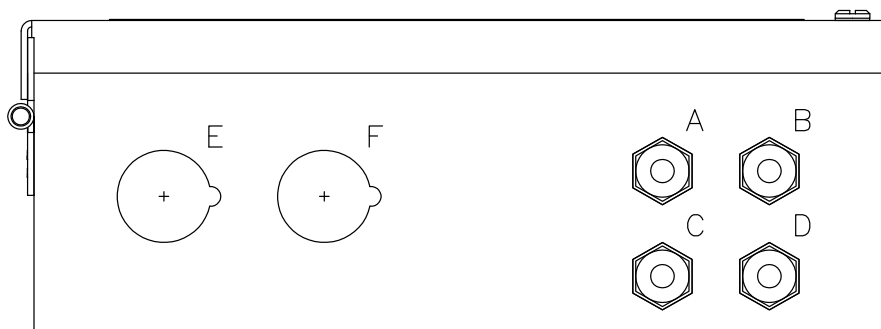

### CONNECTION CODE:

- A. HI SENSOR 1
- B. LO SENSOR 1
- C. HI SENSOR 2 (OPTION)
- D. LO SENSOR 2 (OPTION)
- E. DC SIGNAL OUTPUTS
- F. AC POWER INPUT

**Sensor 1 transducer:** Pair 316 stainless steel 1/8" FPT fittings used for low flow, Extended or sensor 1 Dual mode or as the minimum pressure port for Split Min/Max mode

**Sensor 2 transducer:** Pair 316 stainless steel 1/8" FPT fittings for sensor 2 Dual mode or as the maximum pressure port Split Min/Max mode

## 2.7 POWER/SIGNAL CONNECTIONS

Power and signal connections are made at the terminal blocks shown below. Input power wiring should be 14 to 18 AWG. Signal wiring should be 18 to 22 AWG. The maximum wire gauge that the terminal strips can accommodate is 14AWG. No more than two wires should be connected to any one terminal. 18 AWG is the maximum gauge wire that can be doubled up in one terminal.



### CAUTION

The OAM II transmitter is a low voltage device (24V AC/DC). Connecting the transmitter to high voltage power (e.g. 110 VAC) may cause damage and will void the warranty.



### CAUTION

PWR: (L +) for Line, (N -) for Neutral and (G) for Ground. See figure above for details. The OAM II can be powered by either 20-32VAC 50/60 Hz or 20-40VDC.



### CAUTION

The earth ground is required on all OAM II transmitter installations. Omitting the connection to earth ground could result in poor performance and may void the warranty.

**Mini USB Connector:** Provided for field service. See figure above for details.

**I/O:** AO1 (+) and (-), AO2 (+) and (-), AO3 (+) and (-). See figure above for details.

**NETWORK:** RS485 BACnet or MODBUS. (+) and (-) are for the RS485 signal. (G) is RS485 common. (S) is for the shield. See figure above for details.

**ON/OFF Switch:** There is an ON/OFF switch located in the lower left hand corner of the front cover of this transmitter. Briefly press the switch twice to turn on. Press the switch once to turn off. If power fails while the transmitter is ON, it will restart automatically.



## SECTION 3.0: OPERATION

### Start-up

Press the power button located in the lower left hand corner of the cover. The pushbutton must be pressed twice to power on. At power-up, you will see the current version of the software and the company logo displayed. This will disappear after a brief pause, and the normal display will appear.

Information shown on this screen (flow, temperature, velocity, etc.) will vary based on the OAM II operating mode. In addition, system status data provided at the top of the display window and the user defined locations tag is displayed at the bottom. Default display settings based on the operating mode are provided below.

User interface for programming

Power Switch

Press twice for On and once for OFF.



The user interface consists of 4 pushbuttons. These are only used to access the programming mode.

### 3.1 OPERATING MODES

The displayed information is dependent on the configuration of the OAM II (operating mode). The operating modes for the VOLU-flo/OAM II is are Low Flow (Std.), Extended (Ext), Split Min/Max and Dual.

**Low Flow** – Single transducer (100-600 FPM)

**Extended** – Two transducers in series (stacked) to extend the range

**Split Min/Max** – Two transducers in parallel to allow for two different ranges to be blended to a single flow

**Dual** – Two transducers which are physically in the same transmitter, but monitor separate ducts and work autonomously from each other

### 3.2 DISPLAY OPTIONS BASED ON OPERATING MODE

#### For Low Flow/Extended Mode:

- Line 1 is for Flow
- Line 2 can display Velocity/Temperature/DP/None
- Line 3 can display Velocity/Temperature/DP/None
- Line 4 can display Velocity/Temperature/DP/None

#### For Split Min/Max mode:

- Line 1 is for Flow
- Line 2 can display Velocity Min/Flow Min/DP Min/None
- Line 3 can display Velocity Max/Flow Max/DP Max/None
- Line 4 can display Temperature or None

#### For Dual Mode:

- Line 1 is for channel 1 Flow
- Line 2 can display Velocity Velocity/Temperature/DP/None
- Line 3 is for channel 2 Flow
- Line 4 can display Velocity Velocity/Temperature/DP/None



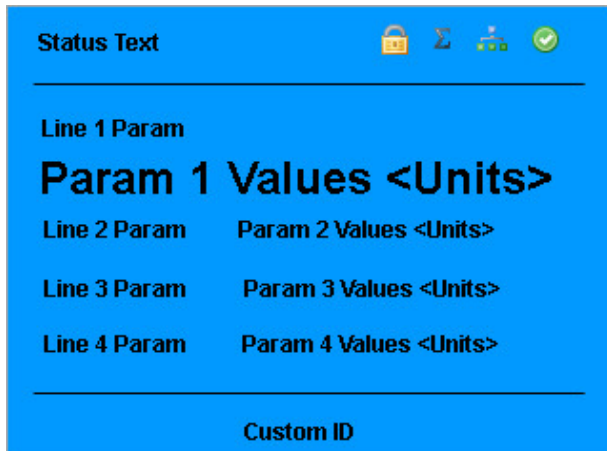

The Main System Display for Split/Ext/Low

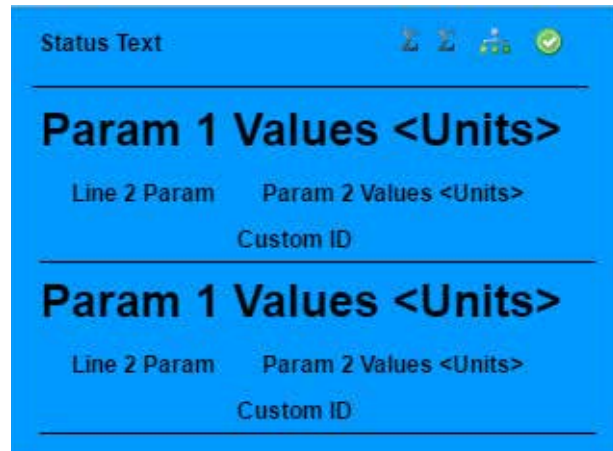

The Main System Display for Dual

### 3.3 STATUS BAR

An upper status bar is always displayed indicating the general operational status of the unit. The following status' are indicated on the upper left hand corner of the display:

Message	Blue on Blue	Normal Operation
Out Of Range - High	Yellow on Blue	If the flow exceeds the design flow max setting
Monitor Temp Low	Yellow on Blue	Transducer temperature too low (<-50 °F)
Monitor Temp High	Yellow on Blue	Transducer temperature too high (>120°F)

## SECTION 4.0: PROGRAMMING MENUS

Press ENT at any time to access the programming menus.

Pushbutton Definitions

Four pushbuttons control the OAM II:

Button	In an Editable Field	In a Selectable Field
ENT	Press once to select next character Press twice to enter the value and go to the next field	To select the value and go to the next field
ESC	Press once to delete the character to the left	Exits the menu, discards change
UP	Selects the next character (note: some fields support alpha or numeric or both)	Selects the next item in the list (note: once at the top of the list, this button has no effect)
DN	Selects the next character (note: some fields support alpha or numeric or both)	Selects the next item in the list (note: once at the bottom of the list, this button has no effect)

## Password Menu

If the password has been set previously, the following screen will be displayed:

Enter the password and you will be brought to the menus selection screen. Information regarding the password settings can be found in the Service Menu and is discussed later in this manual.

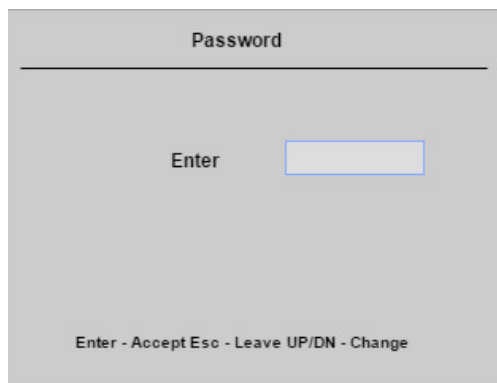

The screenshot shows a screen titled "Password". Below the title is a horizontal line. Underneath, the word "Enter" is followed by a rectangular input field. At the bottom of the screen, the text "Enter - Accept Esc - Leave UP/DN - Change" is displayed.

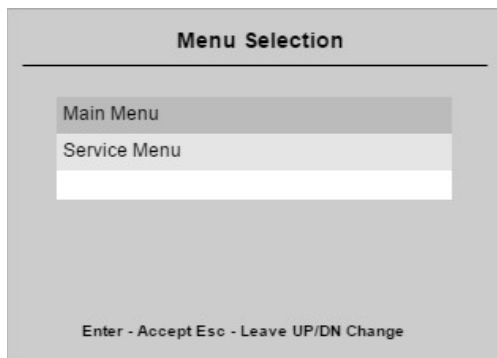

The screenshot shows a screen titled "Menu Selection". Below the title is a horizontal line. Underneath, there is a list of two menu options: "Main Menu" and "Service Menu". The "Main Menu" option is highlighted with a grey background. At the bottom of the screen, the text "Enter - Accept Esc - Leave UP/DN Change" is displayed.

### 4.1 MAIN MENU

In this screen select Main Menu or Service Menu, depending on the function you wish to carry out.

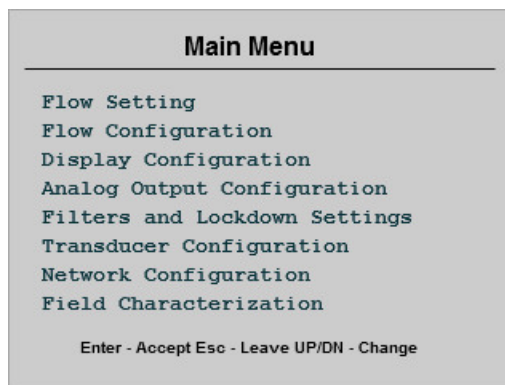

The screenshot shows a screen titled "Main Menu". Below the title is a horizontal line. Underneath, a list of menu options is displayed: "Flow Setting", "Flow Configuration", "Display Configuration", "Analog Output Configuration", "Filters and Lockdown Settings", "Transducer Configuration", "Network Configuration", and "Field Characterization". At the bottom of the screen, the text "Enter - Accept Esc - Leave UP/DN - Change" is displayed.

### 4.2 FLOW SETTINGS (LOW/EXT/SPLIT/DUAL)

Flow settings will set the engineering units for the whole system. You cannot individually change units on other menu pages; for example, if you set the units to be in US and the velocity to be in FPM, the lockdown (low flow cutoff) settings will be in FPM.

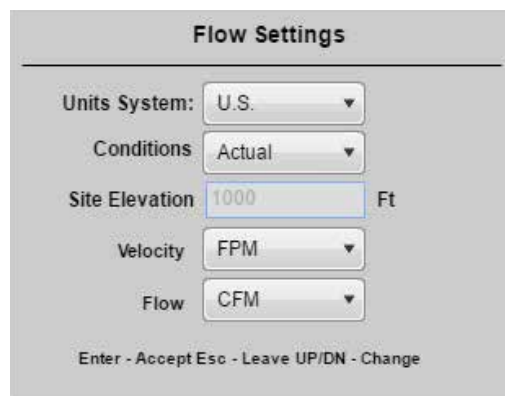

The screenshot shows a screen titled "Flow Settings". Below the title is a horizontal line. Underneath, there are five settings, each with a dropdown menu: "Units System" (set to U.S.), "Conditions" (set to Actual), "Site Elevation" (set to 1000 Ft), "Velocity" (set to FPM), and "Flow" (set to CFM). At the bottom of the screen, the text "Enter - Accept Esc - Leave UP/DN - Change" is displayed.

**Units System** - Select between SI or US. The dropdowns for flow and velocity will present the units for the system selected.

**Conditions** - Select between actual and standard flow conditions. This affects the flow results, so make sure you select the correct conditions for your application. Standard flow normalizes data to 68 °F and 29.92” Hg.

**Site Elevation** - Enter site elevation. This is a static value which is used to calculate actual flow. This field should represent the altitude where the system is installed.

**Velocity** - Select velocity units. Units of velocity are FPM or FPS for US and MPM or MPS for SI.

**Flow** - Select flow units. Units for flow are CFM or CFH for US and LPS, LPM or CMH for SI.

### 4.3 FLOW CONFIGURATION (LOW/EXT)

This menu shows the items which allow a user to configure the OAM for installation.

**Inlet Type** - The inlet type is selected by the user based on the installation. The options are:

- Ducted OAM
- Ducted 63%
- Inlet OAM
- Inlet 63%
- Other

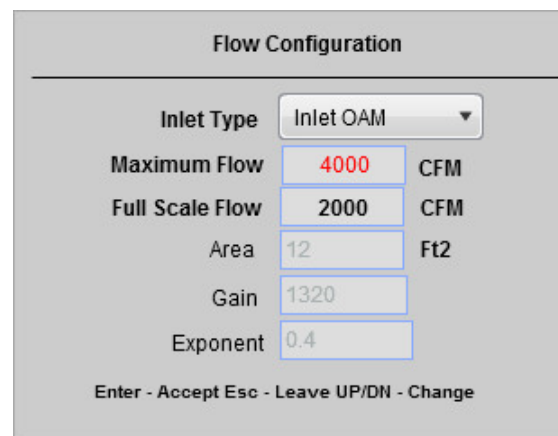

Flow Configuration		
Inlet Type	Inlet OAM	
Maximum Flow	4000	CFM
Full Scale Flow	2000	CFM
Area	12	Ft <sup>2</sup>
Gain	1320	
Exponent	0.4	
Enter - Accept Esc - Leave UP/DN - Change		

Each selection corresponds to a default gain and exponent, used to calculate flow. If the user selects “Other” a default gain of 1600 and an exponent of 0.5 is used. This can be changed based on the field characterization which is discussed later in this document.

## Design Flow Max

This is the upper flow limit based on the selected transducers. The value entered cannot exceed corresponding DP span of the installed transducer. The transducers DP span controls the maximum flow which can be achieved. The user should set this value to a range which they expect represents the duct or inlet they are monitoring. Based on the user set value, the analog outputs will represent the flow. Therefore, if the design flow max is set to 2000, and the flow hits 1000, the analog output will be at 50% of its scale.

## Area

This is an editable field which controls the flow value. It is important for the user to make sure this is accurately entered so the system flow value is also accurate.

## Gain and Exponent

These are read-only fields to indicate what the gain and exponent is in the system. These values will change if field characterization is turned on and the calculation modified these values.

## Flow Configuration (Split and Dual)

The following two dialogs are identical, but one refers to the two separate inlets of a Dual mode system and the other to the inlets of a Split Mode one. The inlets are both configurable and all the other values are the same as the previous screen. The main difference is how the analog outputs work with the two different Equipment Types. For Dual mode, the AO1 output represents the System 1 and AO2 represents the System 2. In Split mode, the Total Flow is represented on AO1 only, AO2 can represent Minimum flow or Temperature, and AO3 can represent ECON flow or Temperature.

Flow Configuration		
	System 1	System 2
Inlet Type	OA Inlet 63%	OA Inlet 63%
Max Flow	4000	4000
FS Flow	2000	2000
Area	12	12
Gain	1320	1320
Exponent	0.4	0.4
		CFM
		FT2

Enter - Accept Esc - Leave UP/DN - Change

Flow Configuration		
	Economizer	Minimum
Inlet Type	OA Inlet 63%	OA Inlet 63%
Max Flow	4000	4000
FS Flow	2000	2000
Area	12	12
Gain	1320	1320
Exponent	0.4	0.4
		CFM
		FT2

Enter - Accept Esc - Leave UP/DN - Change

#### 4.4 DISPLAY CONFIGURATION (LOW/EXT/SPLIT/DUAL)

This screen has the same dialog items for all modes, but choices in the dialog items varies depending on Equipment Type.

**Line 1 Parameter** - This is mandated as flow. It has no other options

**Line 2 Parameter -**

- Low/Ext – Velocity/Temperature/DP
- Split – Flow Min/Vel. Min/DP Min/None
- Dual – Velocity/Temperature/DP/None

**Line 3 Parameters**

- Low/Ext – Velocity/Temperature/DP
- Split – Flow Max/Vel. Max/DP Max/None
- Dual – Flow

**Line 4 Parameters**

- Low/Ext – Velocity/Temperature/DP
- Split - Temperature
- Dual – Velocity/Temperature/DP/None

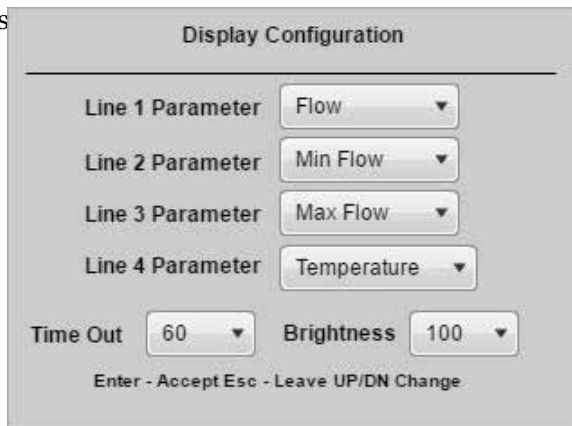

**Time Out** - This refers to the time the menu system stays active. If the user leaves the system in the menu screen it will eventually timeout and return to the main display.

**Brightness** - This is a real-time control of the LCD backlight. Selecting a value will immediately cause a change to the backlight.

#### 4.5 ANALOG OUTPUT CONFIGURATION - This menu controls the operation of the analog outputs.

**Output Type** - This controls how the analog output is scaled and represented. The three choices are 4-20mA, 0-10VDC or 0-5VDC. The system sets all the outputs to the same mode.

**Output 1**

- Low/Ext – Flow
- Split – Total Flow
- Dual – Flow (for System 1)

**Output 2**

- Low/Ext – DP
- Split –Min Flow/Temperature
- Dual –Flow (for System 2)

**Output 3**

- Low/Ext – Temperature
- Split – ECON Flow/Temperature
- Dual – Temperature

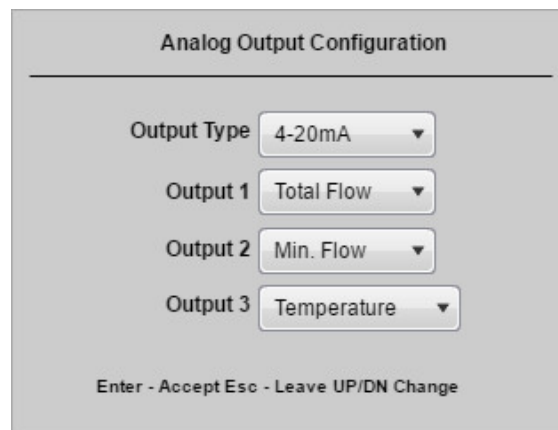

## 4.6 FILTER AND LOCKDOWN SETTINGS

For each mode, there is a slight difference in the dialog settings:

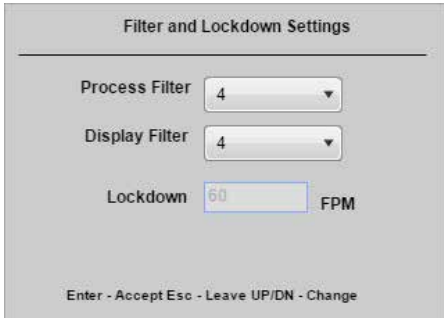
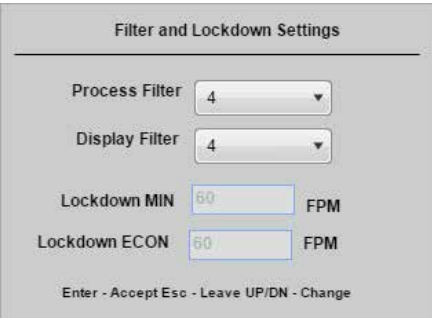
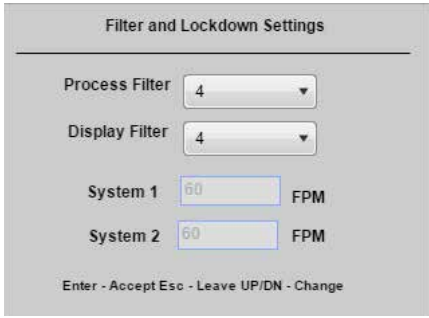
 <p>Filter and Lockdown Settings</p> <p>Process Filter <input type="text" value="4"/></p> <p>Display Filter <input type="text" value="4"/></p> <p>Lockdown <input type="text" value="60"/> FPM</p> <p>Enter - Accept Esc - Leave UP/DN - Change</p>	 <p>Filter and Lockdown Settings</p> <p>Process Filter <input type="text" value="4"/></p> <p>Display Filter <input type="text" value="4"/></p> <p>Lockdown MIN <input type="text" value="60"/> FPM</p> <p>Lockdown ECON <input type="text" value="60"/> FPM</p> <p>Enter - Accept Esc - Leave UP/DN - Change</p>	 <p>Filter and Lockdown Settings</p> <p>Process Filter <input type="text" value="4"/></p> <p>Display Filter <input type="text" value="4"/></p> <p>System 1 <input type="text" value="60"/> FPM</p> <p>System 2 <input type="text" value="60"/> FPM</p> <p>Enter - Accept Esc - Leave UP/DN - Change</p>
<b>Low/Ext</b>	<b>Split</b>	<b>Dual</b>

**Process Filter** - The process filter is used to smooth the signal fed to the analog outputs. The settings are from 1-10, where 1 is the softest filter and 10 is the hardest filter. Typically, 2-4 will give a filtered signal which is responsive, but provides some dampening. This tends to depend on the application where air flow turbulence can make the signal somewhat noisy.

**Display Filter** - Same as the process filter, but can be set to a higher level so a user will not see the signal change rapidly, this separate filtering approach allows the signal integrity to be preserved for the analog output.

**Lockdown Setting** - Works in velocity units which are carried over from the Flow Settings menu page. This setting applies to the relevant inlet or duct, depending on Equipment Type.

## 4.7 TRANSDUCER CONFIGURATION

This menu page varies based on operating mode.

**Low**

**Ext/Split/Dual**

**Transducer/Transducer 1/Transducer 2** - Transducer selections must match the installed transducers. Contact Air Monitor for assistance if you believe you need to install different transducers.



### CAUTION

Do NOT change this setting without changing the installed transducer. Doing so will cause significant flow measurement errors.

**Transducer Units** - Only an option when in SI mode, US units are always in in-w.c.

## 4.8 NETWORK CONFIGURATION

This menu allows the user to set up the serial communications network. It can be used to configure the device for BACnet MS/TP or MODBUS RTU networks. When the network is enabled, the user will see the following icon next to the “System Run” indicator.



**Network Type - BACnet settings**

**Baud Rate** - Available in 9600/19200/38400/56700/76800/115200 (Default: 38400)

**Device ID (Instance Number)** - Enter a value between 0 – 4,194,303.(Default: 1)

**Device Address** - Enter an address between 0 – 127. (Default: 1)

**Max Masters** - Enter a number between 0 – 127. (Default: 127)

**Network Type – MODBUS Settings**

**Baud Rate** - Available in 9600/19200/38400/56700/76800/115200 (Default: 19200)

**Device Address** - Enter an address between 1 – 254. (Default: 1)

**Parity** - Select from EVEN, ODD or NONE. (Default: Even)

## 4.9 FIELD CHARACTERIZATION

This menu allows the user to field characterize (FC) system flow and adjust the factory calibration parameters in the OAM II. When FC is enabled, the icon shown below appears in the status bar of the main display. When operating in Split Min/Max or Dual mode, there are two icons shown indicating that both inlets have been characterized.

 Field Characterization has been turned on

Each mode has slightly different settings, as shown below. When operating in Low/Ext, FC has a single drop down option to enable or disable FC. When operating in Split or Dual modes, the options change to allow for separate characterization of each inlet. In Split mode, the options change to Min On/Min Off and ECON On/ECON Off. In Dual mode, the options are System1 On/Off and System2 On/Off.

Field Characterization	Field Characterization	Field Characterization
<div style="border: 1px solid black; padding: 5px;"> <p style="text-align: center;">On ▾</p> <p><input type="radio"/> Calculate</p> <p><input type="radio"/> Manual</p> <p style="font-size: small;">Enter - Accept Esc - Leave UP/DN - Change</p> </div>	<div style="border: 1px solid black; padding: 5px;"> <p style="text-align: center;">MIN On ▾</p> <p><input type="radio"/> Calculate</p> <p><input type="radio"/> Manual</p> <p style="font-size: small;">Enter - Accept Esc - Leave UP/DN - Change</p> </div>	<div style="border: 1px solid black; padding: 5px;"> <p style="text-align: center;">System1 On ▾</p> <p><input type="radio"/> Calculate</p> <p><input type="radio"/> Manual</p> <p style="font-size: small;">Enter - Accept Esc - Leave UP/DN - Change</p> </div>
<b>Low/Ext</b>	<b>Split</b>	<b>Dual</b>

If you enable the field characterization you will be advanced to the Calculate radio button. Press the ENT key again and you will enter this menu. This is the same menu is used for all modes except that in Split or Dual mode, the menu is used only for the selected inlet.



### CAUTION

Data must be entered as velocity (e.g. FPM) in actual, not standard, flow conditions.

**Number of Points** - Allows the user to select the number of points.

**Data Points** - There are two columns shown on the menu, one for Reference (the test and balancer results) and one for OAM II Points. Data is stored in the system's non-volatile memory. The following are general guidelines characterizing flow based on the number of data points.

**1 Point** - Enter a flow velocity that is at or near the top of the operating range.

**2 Points** - For point 1, enter a flow velocity value that is near the bottom of the operating range. For point 2, enter a flow velocity value that is near the top of the operating range.

**3 Points** - For point 1, enter a flow velocity value that is in the bottom third of the operating range. For point 2, enter a flow velocity value that is in the middle third of the operating range. For point 3, enter a flow velocity value that is in the upper third of the operating range.

**Characterization Calculator**

---

Number of Points 3 ▾

Data points must be velocity only

	Reference	OAM II Points
Point 1	<input style="width: 100%;" type="text"/>	<input style="width: 100%;" type="text"/>
Point 2	<input style="width: 100%;" type="text"/>	<input style="width: 100%;" type="text"/>
Point 3	<input style="width: 100%;" type="text"/>	<input style="width: 100%;" type="text"/>

Enter - Accept Esc - Leave UP/DN - Change



## 5.0 SERVICE MENU

The Service Menu is designed to allow a user to set parameters for the system, perform field calibrations and view system information. When the user selects the Service Menu option the following menu will be seen:

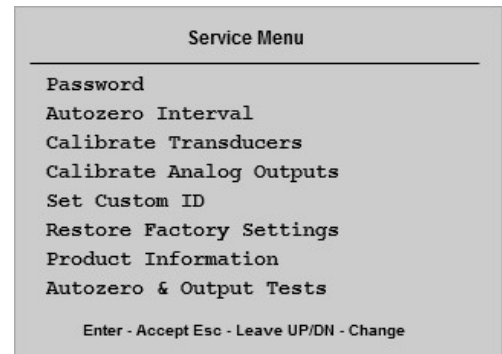

Service Menu

---

Password  
 Autozero Interval  
 Calibrate Transducers  
 Calibrate Analog Outputs  
 Set Custom ID  
 Restore Factory Settings  
 Product Information  
 Autozero & Output Tests

Enter - Accept Esc - Leave UP/DN - Change

### 5.1 PASSWORD

To change the password, enter your new password into the editable field. This overwrites the old password. The password can be up to 8 digits. Alpha and numeric characters are supported. The dropdown will allow the user to disable the password if so desired.

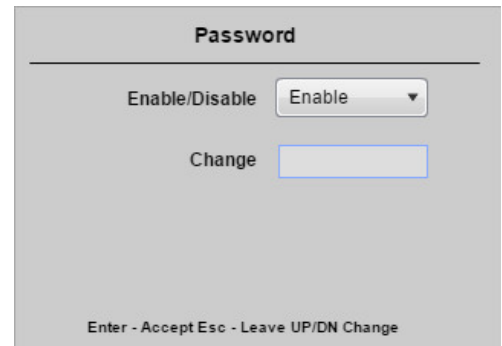

Password

---

Enable/Disable

Change

Enter - Accept Esc - Leave UP/DN Change

### 5.2 AUTOZERO INTERVAL

This menu allows the user enable or disable the autozero function and set how often autozeroing occurs. Typically, once a day is sufficient for this function. The interval is set in hours.

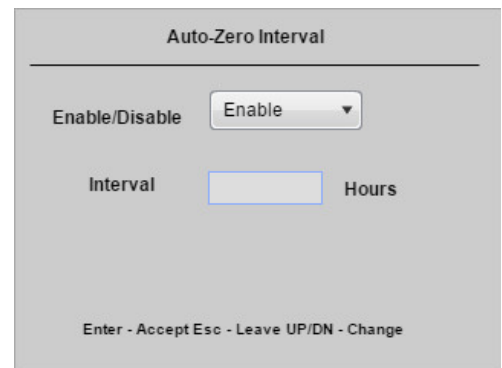

Auto-Zero Interval

---

Enable/Disable

Interval  Hours

Enter - Accept Esc - Leave UP/DN - Change

### 5.3 CALIBRATE TRANSDUCERS

This function allows the user to field calibrate the transducers. The user will need to supply a known air pressure source to the system (to act as a measurement reference).

Options for calibrating Xdcr1 and, if used, Xdcr2 will be shown depending on the operating mode. The user will connect the input pressure to the transducer input, and press calibrate. The zero point should be zero pressure. The span point requires the user to set the known pressure source.

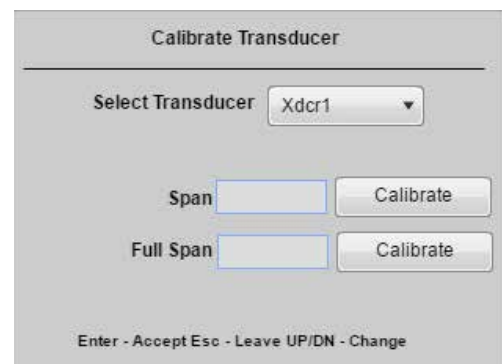

Calibrate Transducer

---

Select Transducer

Span

Full Span

Enter - Accept Esc - Leave UP/DN - Change

## 5.4 ANALOG OUTPUT CALIBRATION

The following procedure allows for field calibration, when required. This menu will guide the user through the steps of the calibration.

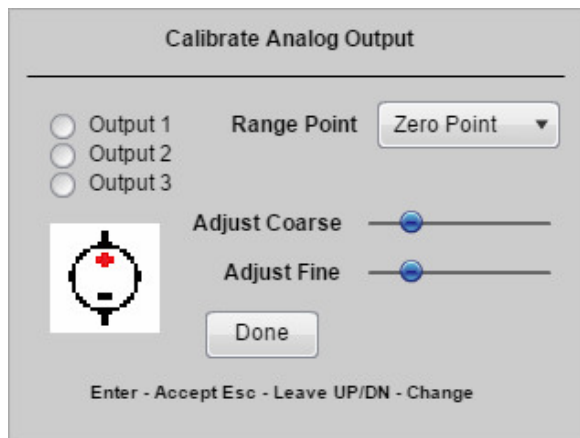
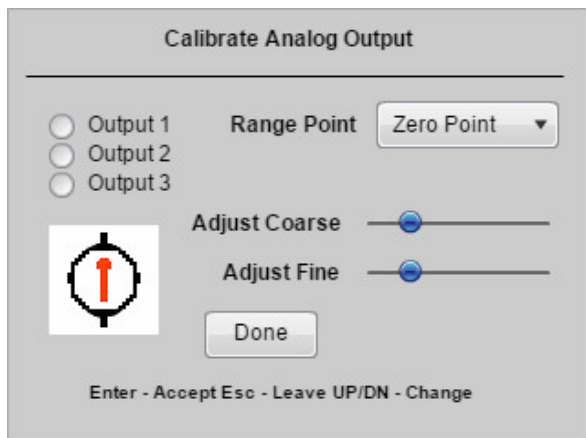

The icons on the screen indicate the “Output Type” setting that entered in the Analog Output Configuration screen.



Current Icon



Voltage Icon

To use this screen, select the output you wish to calibrate. Place the meter on the plus/minus of the terminal strip and make sure the meter is setup for current or voltage mode. Navigate to the slider, and adjust to get close to either 0V or 4mA.

Once on target, press enter. This will take you back to the Range Point selector (which has been automatically pre-selected to Full). Press enter and repeat the procedure, this time for the Full span. At any point, you can exit the menu and the process will restart.

## 5.5 SET CUSTOM ID

This dialog allows for a lpha-numeric entry of up to 20 characters. This entry is visible on the bottom of the main display screen and it is written to the Device Name field in the BACnet device object.

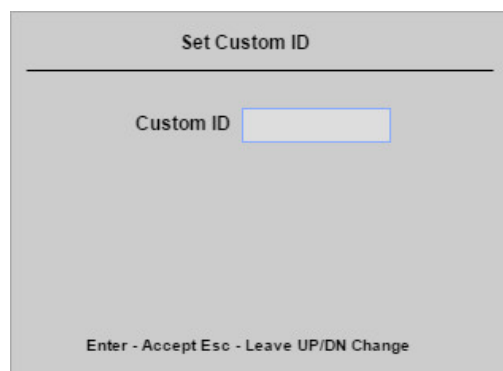

## 5.6 **FACTORY SETTINGS**

This menu allows the user to return the system back to the factory settings.



### IMPORTANT NOTE

Returning OAM II to factory settings will erase all field characterization data.

## 5.7 **PRODUCT INFORMATION**

This screen provides system set up data.

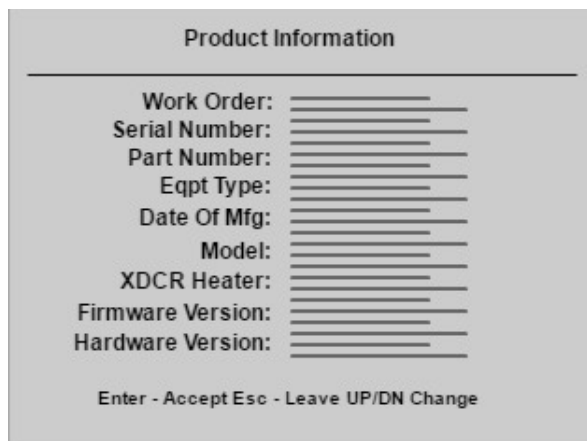

## 5.8 **AUTOZERO AND ANALOG OUTPUT TEST**

This menu is used to validate that the outputs are in calibration and the Autozero function is working. You can activate the Autozero using the 'Run' button and the system will immediately perform an Autozero. The other buttons will set the analog outputs to full scale. Use a multimeter and verify the full-scale value. This would be 20mA for current mode or 5/10VDC for voltage mode. Escape returns the system back to run mode.

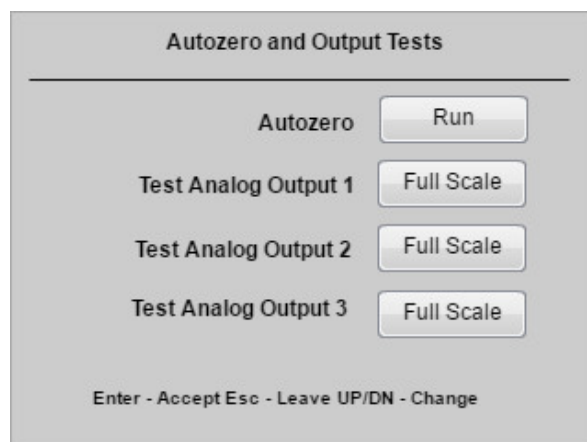

## 6.0 COMMUNICATIONS

The OAM II is provided with BACnet MS/TP and MODBUS RTU as serial communications protocol options. BACnet is the default setting. The field configurable serial communications interface is described in the following pages. Refer to section 2.7 for detailed information on wiring connections.



### CAUTION

Do not connect shield drains to the common terminal.

Air Monitor recommends that 3-wire systems with a separate shield be used for communications. The interface can operate on 2-wire networks with no common, but this configuration is more susceptible to noise.

#### BACnet MS/TP

Transceiver:	Isolated, 3-wire, half-duplex (1/3 unit load)
Recommended maximum units per segment:	32
BACnet address range:	1 - 255 (Default: 1)
BACnet device ID (Instance number):	0 – 4,194,303 (Default: 1)
Max master range:	0 – 127 (Default: 127)
Baud Rate: 9	600, 19200, 38400, 57600, 76800 or 115200 (Default: 38400)

#### BACnet OBJECT TYPES

BACnet Object Type and number of Objects implemented: Device 1  
Analog Input – 4 or 8, depending on operating mode See below for details.

#### Protocol Implementation Statement

BACnet Protocol Revision: 9

Device Profile (Annex L): BACnet Application Specific Controller (B-ASC)

MS/TP master (Clause 9), baud rate(s): 9600, 19200, 38400, 56700, 76800, 115200

Device Address Binding: No

BBMD support registration by Foreign Devices: No

Character Set Supported: ANSI X3.4

BACnet Interoperability Building Blocks Supported (Annex K):

Data Sharing – Read Property-B (DS-RP-B)

Data Sharing – Read Property Multiple-B (DS-RPM-B)

Data Sharing – Write Property-B (DS-WP-B)

Device Management – Dynamic Device Binding-B (DM-DDB-B)

Device Management – Dynamic Object Binding-B (DM-DOB-B)

Device Management – Device Communication Control-B (DM-DCC-B)

Device Management – Reinitialize Device-B (DM-RD-B)

## Standard Objects Supported

### Device Object

Object Identifier	1	Writeable	0 – 4,194,303
Object Name	OAM-II	Writeable	Alpha-numeric; 20 char limits. See “Custom ID” setting in the Service Menu.
Object Type	Device	Read-only	
System Status	Operational	Read-only	
Vendor Name	Air Monitor Corporation	Read-only	
Vendor ID	58	Read-only	
Model Name	OAM-II	Read-only	
Location	Default Location	Read-only	
Description	Airflow Measurement	Read-only	
Protocol Version	1	Read-only	
Protocol Revision	9	Read-only	
Services Supported	readProperty, readPropertyMultiple, writeProperty, deviceCommunicationControl, reinitilizeDevice, who-Has, who-is	Read-only	
Object Types Supported	Analog-input, Device	Read-only	
Object List	Depends on operating mode: <b>Loe/Ext:</b> (4) Total Flow, RTD, Velocity, DP <b>Split:</b> (8) Total Flow, Flow Min, Flow Max, RTD, Vel Min, Vel Max, DP low, DP high <b>Dual:</b> (8) System 1 Total Flow, System 2 Total Flow, RTD, System 1 Vel, System 2 Vel, System 1 DP, System 2 DP	Read-only	
Max ADPU Length	128	Read-only	
Segmentation Supported	No Segmentation	Read-only	
APDU Time-out	3000	Read-only	
# of APDU Retries	3	Read-only	
Max Master	127	Writeable	
Device Address Binding	{}	Read-only	
Database Revision	3	Read-only	

## Analog Inputs

Object Identifier	Analog Input-0 to Analog Input-X1	Read-only
Object Name	Various	Read-only
Object Type	Analog-Input	Read-only
Present Value	REAL	Read-only
Status Flags	F, F, F, F	Read-only
Event State	Normal	Read-only
Out of Service	FALSE	Read-only
Description	Various	Read-only
Units	Various	Read-only

For each analog input object, there are four status flags: IN\_ALARM, OUT\_OF\_SERVICE, FAULT and OVERRIDDEN. Only the FAULT flag is used in this product. If there is an out-of-range condition or other alarm, the FAULT flag will be set.

## MODBUS

Transceiver:	Isolated, 3-wire, half-duplex (1/3 unit load)
Recommended maximum units per segment:	32
Modbus address range:	1 - 255 (Default: 1)
Parity:	Even, Odd or None (Default: Even)
Baud Rate:	9600, 19200, 38400, 57600, 76800 or 115200 (Default: 19200)

Below is the register map for the OAM II transmitter:

## OAM II Modbus Registers

Operating Mode	Register Description	Register Type	Address	Data Type
Low/Ext	Total Flow	Read Input	40000	float
Low/Ext	RTD	Read Input	40002	float
Low/Ext	Velocity	Read Input	40004	float
Low/Ext	DP	Read Input	40006	float
Split	Total Flow	Read Input	40000	float
Split	Flow Min.	Read Input	40002	float
Split	Flow Max.	Read Input	40004	float
Split	RTD	Read Input	40006	float
Split	Velocity Min.	Read Input	40008	float
Split	Velocity Max.	Read Input	40010	float
Split	DP Low	Read Input	40012	float
Split	DP High	Read Input	40014	float
Dual	System 1 Total Flow	Read Input	40000	float
Dual	System 2 Total Flow	Read Input	40002	float
Dual	RTD	Read Input	40004	float
Dual	System 1 Velocity	Read Input	40006	float
Dual	System 2 Velocity	Read Input	40008	float
Dual	System 1 DP	Read Input	40010	float
Dual	System 2 DP	Read Input	40012	float

DESCRIPTION	REGISTER TYPE	ADDRESS	DATA TYPE	DESCRIPTION
System Velocity Units	Read Input	40201	uint16_t	1 = FPM, 2 = FPS, 3 = MPM, 4 = MPS
System Flow Units	Read Input	40202	uint16_t	1 = CFM, 2 = CFH, 3 = L/S, 4 = L/M, 5 = M3H
System Version	Read Input	40203	uint16_t	
System Version 2	Read Input	40204	uint16_t	MSB = Major, LSB = Minor
Duct / Inlet Type	Read Input	40205	uint16_t	257 = Ducted OAM 514 = Ducted 63% 771 = Inlet OAM 1028 = Inlet 63% 0 = Other
Design Flow Min Setting	Read Input	40206	float	
Design Flow Max Setting (Std/Ext/Split Min/Dual System 1)	Read Input	40208	float	Max Flow to scale Analog Outputs
Duct Area (Std/Ext/Split Min/Dual System 1)	Read Input	40210	float	Duct area size in ft <sup>2</sup> or m <sup>2</sup>
Duct Area (Std/Ext/Split Min/Dual System 2)	Read Input	40212	float	Duct area size in ft <sup>2</sup> or m <sup>2</sup>
System Status	Read Input	40214		1= ALL_OK, 2 = IN ALARM, 3 = IN FAULT, 4 = OOS
DESCRIPTION	REGISTER TYPE	ADDRESS	DATA TYPE	DESCRIPTION
System Units	Read Discreet	20000	boolean	Bit 0: 1 = SI, Bit 0: 0 = US
System Conditions	Read Discreet	20001	boolean	Bit 0: 1 = Std, Bit 0: 0 = Actual
DESCRIPTION	REGISTER TYPE	ADDRESS	Data Type	Description
K-factor	Write Coil 1	50000	boolean	1 = ON, 0 = OFF
System Reset	Write Coil 2	50000	boolean	1 = RESET
DESCRIPTION	REGISTER TYPE	ADDRESS	DATA TYPE	DESCRIPTION
K-factor	Write Multiple Coil	150000	boolean	1 = ON, 0 = OFF
System Reset	Write Multiple Coil	150000	boolean	1 = RESET
DESCRIPTION	REGISTER TYPE	ADDRESS	DATA TYPE	DESCRIPTION
Read Slave ID	N/A	17000	ASCII	Returns string "OAMII"
DESCRIPTION	REGISTER TYPE	ADDRESS	DATA TYPE	DESCRIPTION
K-factor	Read Coil	10000		Returns the state of the K-factor

## 7.0 MAINTENANCE

The OAM II does not contain any parts that require scheduled maintenance.

The following information is provided, as general guidelines, if you wish to establish an inspection/maintenance program. Start with annual inspections and adjust the frequency as required to meet your needs.

### Cleanliness

- Verify condensation (or other sources of liquids) are not present inside the OAM II.

### Mechanical

- Verify signal connections are secure.
- Inspect signal lines for any cracks or leaks.
- Verify mounting hardware is secure.

### Electrical

- Inspect wiring to the OAM II for good connections and absence of corrosion.

### Calibration Intervals

Air Monitor does not recommend a specific time interval between re-calibrations. Calibrations should be scheduled to meet the needs of the facility where the OAM II is installed. For example, critical care facilities may wish to schedule annual re-calibrations while commercial/retail buildings may only schedule re-calibrations at 3-5 year intervals.

## 8.0 TROUBLESHOOTING

Problem	Solution
Display indicates 0 FPM while in Normal Mode	Verify fan is operational.  Verify flow is above lockdown value.  Make sure autozero is not in effect.
Total Flow is greater than the Design Flow Max setting in the Flow Configuration dialog.	The flow setting is too low for the actual flow in the duct. This can be simply fixed by increasing the DFM setting, but this might not be enough. The flow in the duct may be higher than the transducer can handle, so this may require a new transducer.
Temperature value is fixed	Requires a calibration. This can only be done in the factory.
Temperature is very low -50° F	Calibration is not correct  RTD has a loose wire connection
Flow seems high or low for given conditions	The transducer must be sized correctly for the flow in the duct and the system must have the correct span value selected in the Transducer Configuration menu. If these conditions are correct, perform a transducer calibration.  Verify air handler is operating correctly.
If after following the Troubleshooting steps the OAM II continues to operate improperly, contact the Service Department for further assistance.	



## **SECTION 9.0: WARRANTY INFORMATION**

Air Monitor Corporation (hereinafter referred to as “Seller”) warrants that at the time of shipment, products sold pursuant to this contract will be free from defects in materials and workmanship and will conform to the specifications furnished or approved in writing by Seller. No warranty is given that delivered products will conform to catalog sheets, data sheets, and the like, which are subject to change without notice.

Seller will repair or replace, at its option, any product listed under this warranty which is returned freight prepaid to Seller within three (3) years after start-up or thirty-nine (39) months after shipment, whichever comes first, that upon test and examination, proves defective within the terms of this warranty. The warranty period for the OAM II system repaired or replaced shall be for the time remaining on the warranty period of the original components. Purchaser shall notify Seller in writing of such defect within sixty (60) days of discovery of the defect.

This warranty does not extend to any product sold by Seller which has been the subject of misuse, neglect, accident, damage or malfunction caused by interconnection with equipment manufactured by others, improper installation or storage, or used in violation of instructions furnished by Seller, nor does it extend to any product which has been repaired or altered by persons not expressly approved by Seller. Nor does Seller warrant equipment against normal deterioration due to environment; nor items such as lamps, glass, and similar items subject to wear or burnout through usage. Adjustments for items or equipment not manufactured by Seller shall be made to the extent of any warranty of the manufacturer or supplier thereof.

Seller shall not be liable for any special or consequential damages or for loss of damage, directly or indirectly arising from the use of the products. Seller’s warranty shall be limited to replacement of defective equipment and shall not include field removal and installation expenses.

The warranty set forth above is in lieu of all other warranties either express or implied and constitutes the full extent of Air Monitor Corporation’s liability to the customer, or any other party, for breach of warranty.

THERE ARE NO EXPRESS WARRANTIES EXCEPT AS SET FORTH HEREIN AND THERE ARE NO IMPLIED WARRANTIES OF MERCHANTABILITY OF FITNESS FOR ANY PARTICULAR PURPOSE, WHICH ARE PARTICULARLY DISCLAIMED.

Copyright © 2017 Air Monitor Corporation. All printed material should not be changed or altered without permission of Air Monitor Corporation. Any published technical data and instructions are subject to change without notice. Contact your Air Monitor Corporation representative for current technical data and instructions. All brand names, trademarks and registered trademarks are the property of their respective owners. Information contained within this document is subject to change without notice. Visit [www.airmonitor.com](http://www.airmonitor.com) to view and/or download the most recent version of this and other documents.