



1SFC132104M0201 EN, Rev A

Softstarters Type PSTX30...PSTX370

Application manual: Waste water pump

Original instruction

This is the Application manual: Waste water pump for Softstarters Type PSTX30...PSTX370.

Document number: 1SFC132104M0201
Revision: A

Issue date: 2015-03-01

Data can be changed without notice.

We reserve all rights to this document, even in the event that a patent is issued and a different commercial proprietary right is registered. Improper use, in particular reproduction and dissemination to third parties, is not permitted.

This document has been carefully checked. If the user detect an error, he or she is kindly asked to notify us as soon as possible.

The data contained in this manual is intended solely for the product description and is not to be deemed to be a statement of guaranteed properties. In the interests of our customers, we constantly seek to ensure that our products are developed to the latest technological standards. As a result, there may be some differences between the softstarter and the information in this manual.

Author's address:

ABB AB
Control Products
Low Voltage Products
SE-721 61 VÄSTERÅS, Sweden

www.abb.com/lowvoltage

© Copyright 2015. All rights reserved. Data can be changed without notice.

Read this first

Warning and safety

Thank you for selecting this ABB PSTX softstarter. Read carefully and make sure that you understand all instructions before you mount, connect and configure the softstarter.

This manual is an application manual intended for quick and easy installation and usage of a waste water pump with the PSTX softstarter. For complete information, see 1SFC132081M0201 - Softstarters Type PSTX30... PSTX370, Installation and Commissioning Manual available on: <http://new.abb.com/low-voltage/products/softstarters>

- The softstarter shall be installed by authorized personnel only.
- ABB personnel must obey the ABB CISE 15.4 instructions.
- Always read the full manual before you use the softstarter.

Safety notes

In this user manual, these symbols are used:



CAUTION

Caution symbol indicates the presence of a hazard which could result in personal injury.



WARNING

Warning symbol indicates the presence of a hazard which could result in damage to equipment or property.



INFORMATION

Information sign alerts the reader to relevant facts and conditions.

Modifications to data in this manual can be applied without notice.

General safety information



CAUTION

Only authorized and appropriately trained personnel are allowed to install and make the electrical connection of the softstarter in accordance with existing laws and regulations.



WARNING

Examine the softstarter and the package when you unpack your new PSTX softstarter. If there are damages, please contact the transportation company or the ABB reseller/office immediately.



WARNING

Do not lift the softstarter by the connection bars, as this can damage the softstarter.



WARNING

Only authorized and appropriately trained service personnel are allowed to do service and repair on the softstarter. Note: unauthorized repair will effect the warranty.

Softstarters Type PSTX30...PSTX370

Application manual: Waste water pump

[1 Introduction](#)

1

[2 Circuit diagram](#)

2

[3 Connection](#)

3

[4 Set-up](#)

4

[5 User guide](#)

5

1 Introduction

1.1 Purpose of this manual

This is a manual for simplified installation, set-up and operation of a PSTX softstarter with a waste water pump. If the instructions in this manual are followed, the PSTX softstarter will have the most important features activated and controlled by hard wire. If any further functionality or information is requested or if the PSTX softstarter is not controlling a waste water pump, please see 1SFC132081M0201 - Softstarters Type PSTX30... PSTX370, Installation and Commissioning Manual, available on <http://new.abb.com/low-voltage/products/softstarters>. This manual will show how to activate:

- Soft start and stop of pump for normal operation.
- Electronic overload protection, for detection of pump clogging.
- Current under load protection, for detection of dry pump based on current.
- Power factor under load protection, for detection of dry pump based on power.
- Pump cleaning with full voltage forward and fast jog reverse.
- All inputs and outputs that are needed to get an easy control of the PSTX softstarter using push buttons or a PLC with hard wire.

1.2 Needed components

This is the list of recommended pilot devices that is needed to perform the instructions and operations in this manual.



NOTE

Please note that equivalent pilot devices can be used as well. Contact you local ABB representative for more information.

Table 1 Needed components

Quantity	Description	Type names	Article number
1	Double pushbutton for start and stop. White and black, marked with I and O.	MPD17-11B	1SFA611146R1106
1	Contact block holder	MCBH-00	1SFA611605R1100
1	Contact block NO	MCB-10	1SFA611610R1001
1	Contact block NC	MCB-01	1SFA611610R1010
1	Legend plate holder	MA1-8139	1SFA611920R8139
1	Legend plate "Start"	MA6-1044	1SFA611930R1044
1	Legend plate "Stop"	MA6-1045	1SFA611930R1045
1	Yellow pilot light 230V AC	CL-523Y	1SFA619402R5233
1	Green pilot light 230V AC	CL-523G	1SFA619402R5232
1	Toggle switch, 3-position, momentary	MTS2-10B	1SFA611301R1006
1	Contact block holder	MCBH-00	1SFA611605R1100
1	Contact block NO	MCB-10	1SFA611610R1001
1	Blue pushbutton, momentary, 1NO	CP1-10L-10	1SFA619100R1014
1	Emergency stop, 40mm, twist release, 1NC	CE4T-10R-01	1SFA619550R1041

Table 2 Optional components

Quantity	Description	Type name	Article number
1	Extension I/O	DX111-FBP.0	1SAJ611000R0101

2 Circuit diagram

2.3 Circuit diagram for control with push buttons

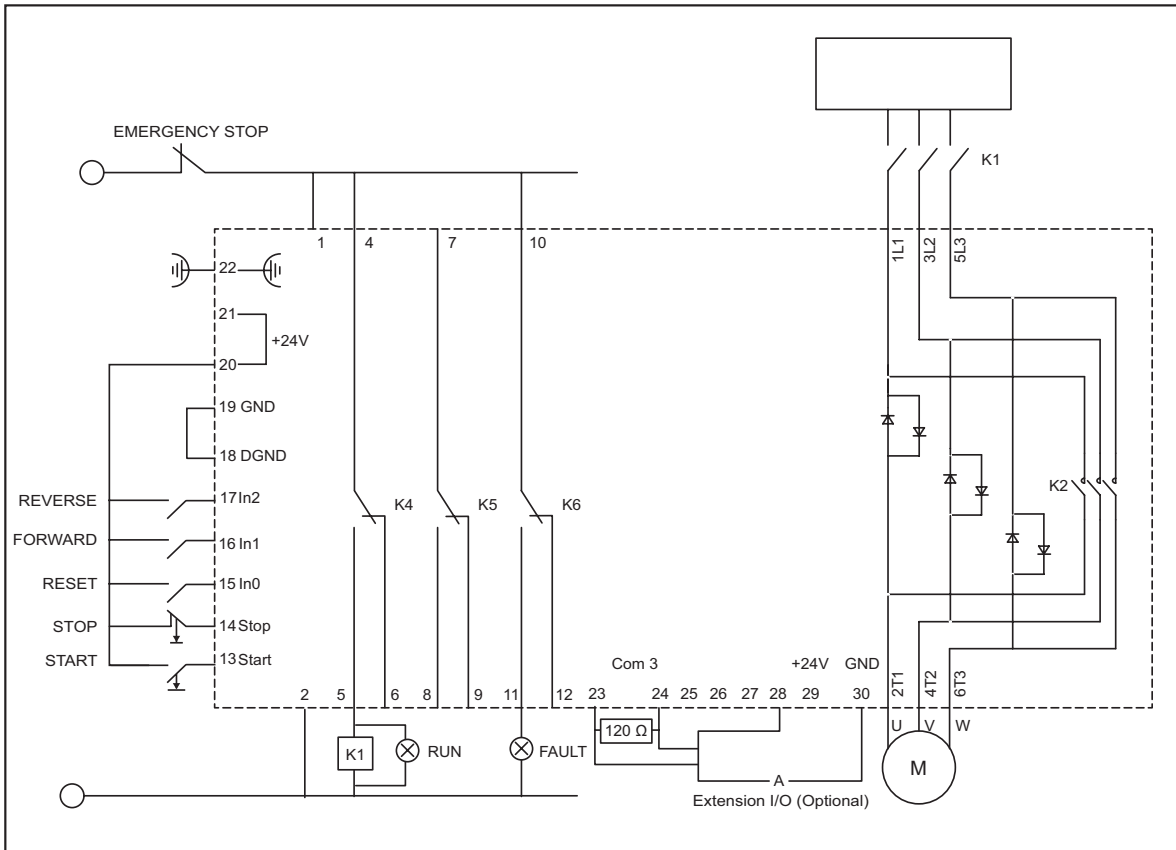

2.4 Circuit diagram for control with PLC

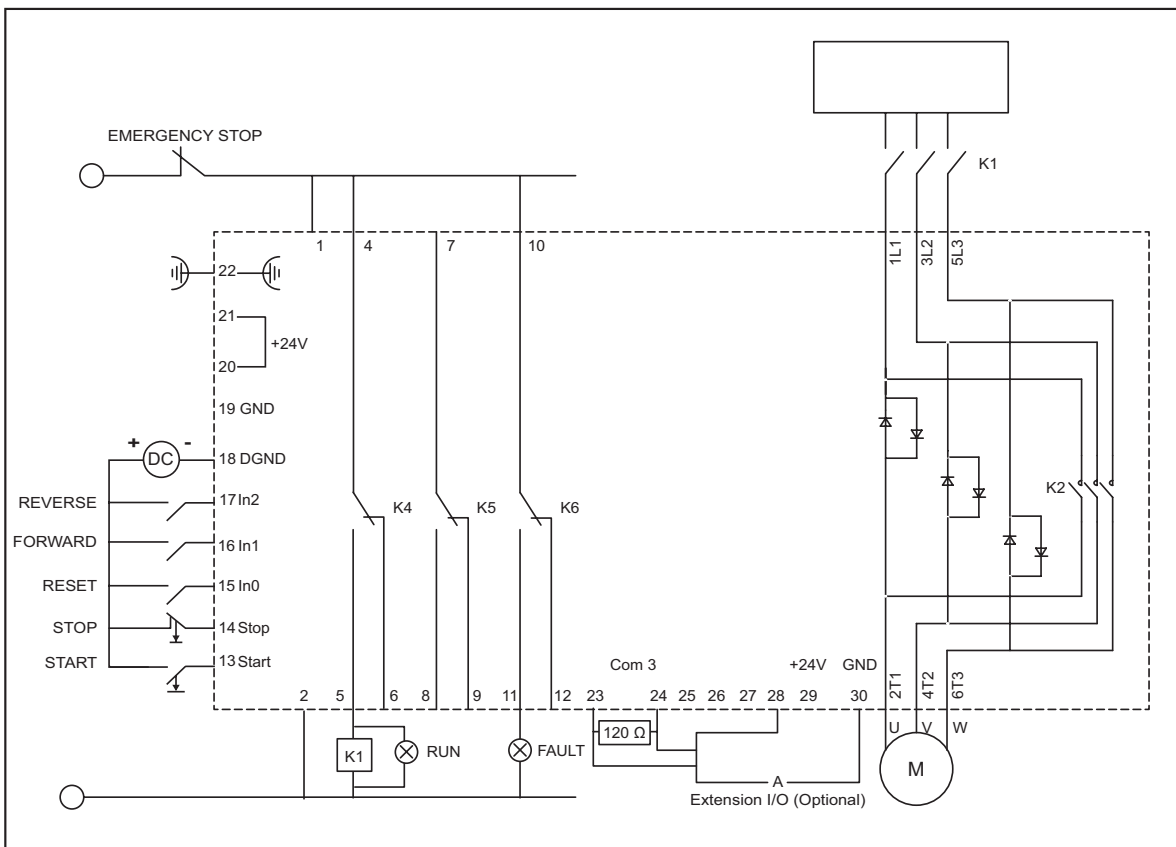

3 Connection

This chapter describes the electrical connections as well as connections for communication devices that can be connected to the softstarter.



WARNING

Mounting and electrical connections of the softstarter shall be made in accordance with local laws and regulations and be performed by authorized personnel.



CAUTION

Hazardous voltage. Can cause death or serious injury. Turn off and lock out all power supplying this device before any work on the softstarter.



WARNING!

Apply the control supply voltage to make sure that the bypass relays are in open position before you connect the softstarters PSTX30...PSTX170 to operational voltage for the first time. If not, the equipment can start accidentally. This is necessary to avoid unintentional starting of the equipment during the connection.



INFORMATION

ABB personell have to obey the instructions in **ABB CISE 15.4**.



WARNING

Capacitors for power factor compensation are not allowed in between the softstarter and the motor, since this can cause current peaks which can burn the thyristors in the softstarter. If such capacitors are to be used, they should be connected on the line side of the softstarter.

For more information, please see 1SFC132081M0201 - Softstarters Type PSTX30...PSTX370, Installation and Commissioning Manual.

3.1 Main circuit



INFORMATION

The voltage dips may not be more than 5% between softstarter and motor. The cable length does not matter.

Softstarters PSTX30...PSTX370 can be connected both In Line, see **1** **Figure 1**,

and Inside Delta, see **2** **Figure 1**.

Use wire connection for PSTX30...PSTX105 see **Figure 2** and terminal connection for PSTX142...PSTX170 see **Figure 3**.

- Connect the line side to terminals 1L1, 3L2, 5L3, see **1** in **Figure 2** and **3**.
- Connect the motor to terminals 2T1, 4T2, 6T3 on the motor side, see **2** in **Figure 2** and **3**.

The terminal marking is printed on the front of the softstarter. For tightening torques and cable thickness,

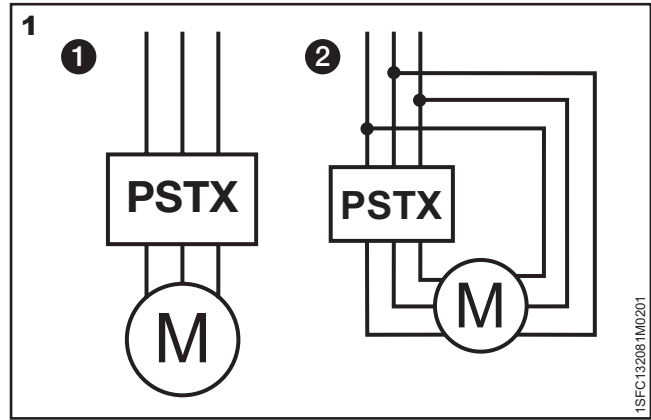

Figure 1: In line (1) and inside delta (2) connection

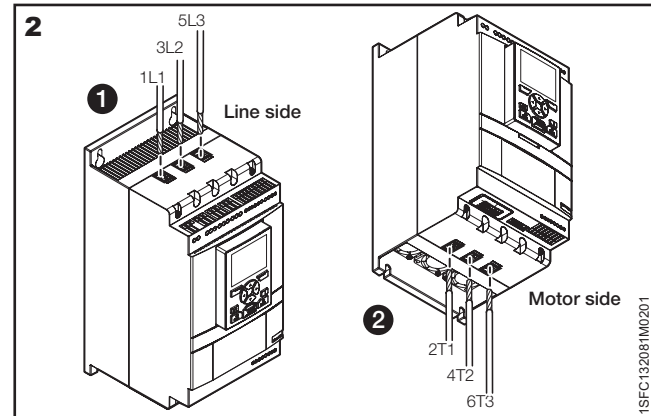

Figure 2: Terminal connection clamps

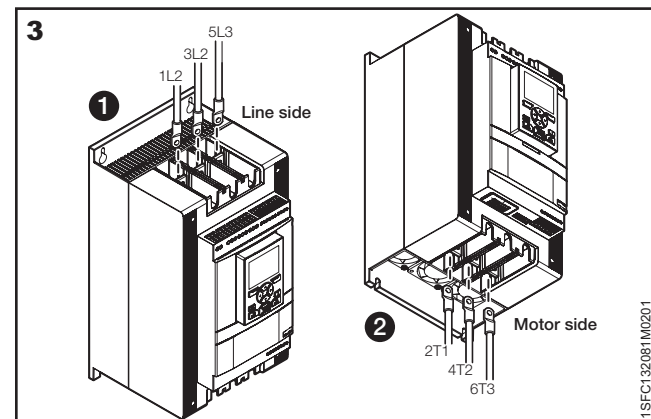

Figure 3: Terminal connection bars

see **chapter 3.1.1 Tightening torques and cable dimensions**.

3.1.1 Tightening torques and cable dimensions

PSTX30...PSTX105				
		8 Nm - 71 lb.in AWG6 .. 2/0 Cu 75°C only Rigid: 10 ... 95 mm ² Flexible: 10 ... 70 mm ² Rigid/flexible: 2x6 ... 2x35 mm ²		
PSTX142...PSTX170				
	11/6-16 UNF-2A 275 lb.in	Using connection module ATK185: AWG4 to 300kcmil Al Cu 75°C only 	 18 Nm - 160 lb.in	Using connection bars
PSTX210...PSTX370				
	3/4-16 UNF-2A 375 lb.in	Using connection module ATK300: AWG4 to 400kcmil ATK300/2: AWG4 to 500kcmil or 2xAWG4 to 2x500kcmil Al Cu 75°C only 	 28 Nm - 240 lb.in	Using connection bars

1SFC132.081M0201

3.2 Control supply and control circuit

Wires in industrial control applications are divided into three groups: main power supply, control supply and control circuit.

Main power supply (1L1, 3L2, 5L3, 2T1, 4T2, 6T3)

Control supply voltage (terminals 1 and 2)

Control circuit (terminals 13 - 21).

2

3.2.1 Control supply voltage - terminals 1 and 2

Connect neutral and phase to terminal 1 and 2.
See **Figure 4**.

i **INFORMATION**
Only use 100-250 V, 50 / 60 Hz supply voltage.

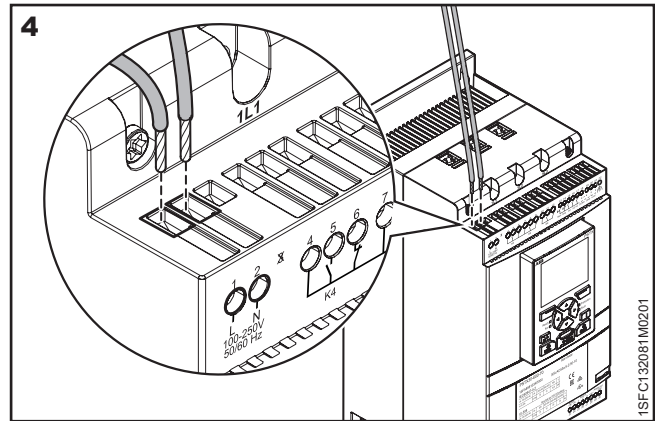

Figure 4: Supply voltage, terminal 1, 2

Tightening torques and cable dimensions.

	<p>M3,5</p> <p>0,5 Nm 4,3 lb.in</p>	<p>3,5 x 0,6 mm (0.138 x 0.024 in)</p>	<p>AWG 12 ... 24</p> <p>0,2 .. 2,5 mm² 2x0,2 .. 1,5 mm²</p> <p>0,2 .. 2,5 mm² 2x0,2 .. 1,5 mm²</p>
--	---	--	--

3.2.2 Functional earth - terminal 22

Softstarters type PSTX85...PSTX370 should be earthed using the terminal 22 as shown in **Figure 5** (one connection is sufficient). Connect the cable to an earthing point close to the softstarter. The cable should be as short as possible. A suitable earthing point is next to the softstarter on the mounting plate, which should also be earthed.

i **INFORMATION**
This is not a protective earth, it is a function earth. The earthing cable should be as short as possible. Maximum length 0.5m.

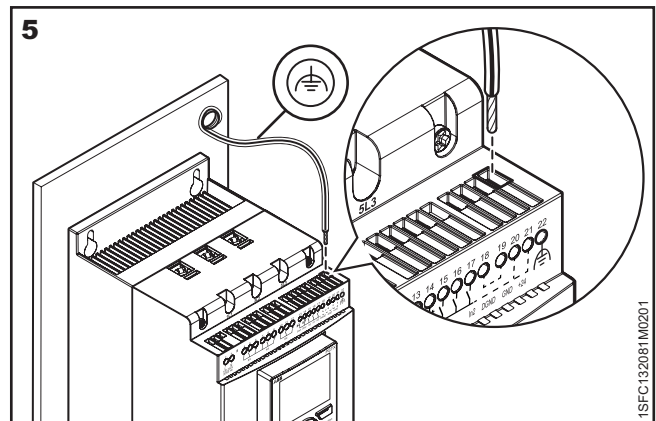

Figure 5: Functional earth, terminal 22

i **INFORMATION**
Do not use functional earth in IT-networks, commonly found in for instance marine applications.

Tightening torques and cable dimensions.

	<p>M3</p> <p>0,5 Nm 4,3 lb.in</p>	<p>3,5 x 0,6 mm (0.138 x 0.024 in)</p>	<p>AWG 12 ... 24</p> <p>0,2 .. 2,5 mm² 2x0,2 .. 1,5 mm²</p> <p>0,2 .. 2,5 mm² 2x0,2 .. 1,5 mm²</p>
--	---------------------------------------	--	--

3.2.3 Connecting Start and Stop terminals to push buttons and PLC

Internal control voltage - Push buttons

The PSTX Softstarter has a built-in holding circuit and does not require sustained signals on start input. Use internal control supply voltage from terminals 20 or 21.

Connect start and stop terminals using conventional circuit with push buttons. See **Figure 6** and **Figure 7**.

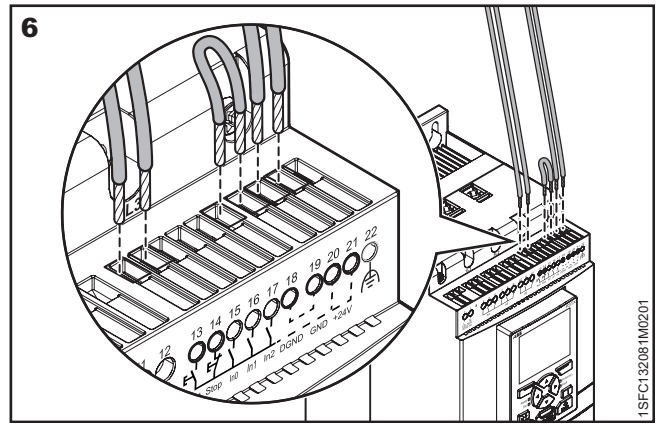

Figure 6: Start and Stop, terminals 13, 14, 18, 19, 20, 21

Connect the white start push button as START and the black stop push button as STOP in **Figure 7**.

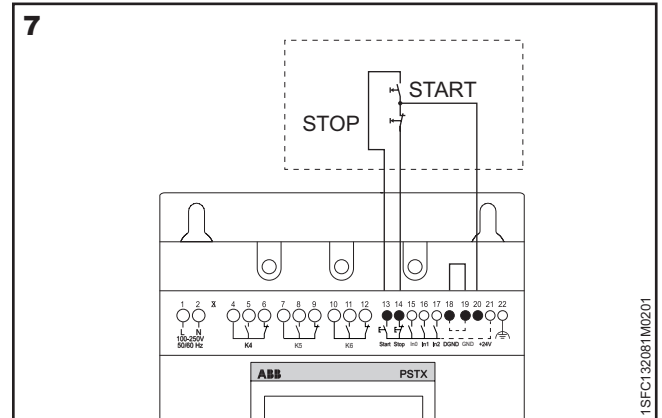

Figure 7: Holding circuit (pulse for start is enough)

Tightening torques and cable dimensions.

	<p>0,5 Nm 4,3 lb.in</p>	<p>3,5 x 0,6 mm (0.138 x 0.024 in)</p>	<p>AWG 12 ... 24</p> <p>0,2 .. 2,5 mm² 2x0,2 .. 1,5 mm²</p> <p>0,2 .. 2,5 mm² 2x0,2 .. 1,5 mm²</p>
--	-----------------------------	--	--

External control voltage - PLC

The softstarter can, if required, also be controlled with an external 24 V DC source from a PLC or similar.

Connect the cables according to **Figure 8** depending on which type of control method is used.



WARNING

Terminal 13, 14, 15, 16 and 17 should be connected using 24V DC only. Other voltages may damage the softstarter and the warranty may no longer be valid.

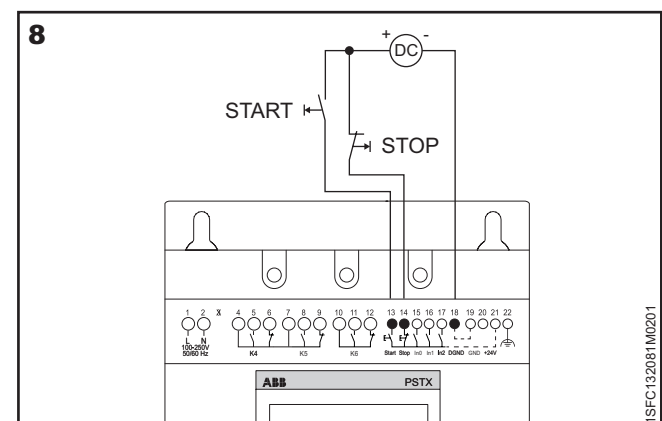

Figure 8: Holding circuit with external control voltage (pulse for start is enough)

Tightening torques and cable dimensions.

	<p>0,5 Nm 4,3 lb.in</p>	<p>3,5 x 0,6 mm (0.138 x 0.024 in)</p>	<p>AWG 12 ... 24</p> <p>0,2 .. 2,5 mm² 2x0,2 .. 1,5 mm²</p> <p>0,2 .. 2,5 mm² 2x0,2 .. 1,5 mm²</p>
--	-----------------------------	--	--

3.2.4 Connecting Reset, Pump cleaning forward and Pump cleaning reverse terminals to push buttons or PLC

The softstarter has three programmable inputs. See **Figure 9**.

- In0, has reset event as default
- In1, should be changed to Pump cleaning forward, **see chapter 4.4.1 05 Slow speed (pump cleaning reverse)**
- In2, should be changed to Pump cleaning reverse, **see chapter 4.4.1 05 Slow speed (pump cleaning reverse)**

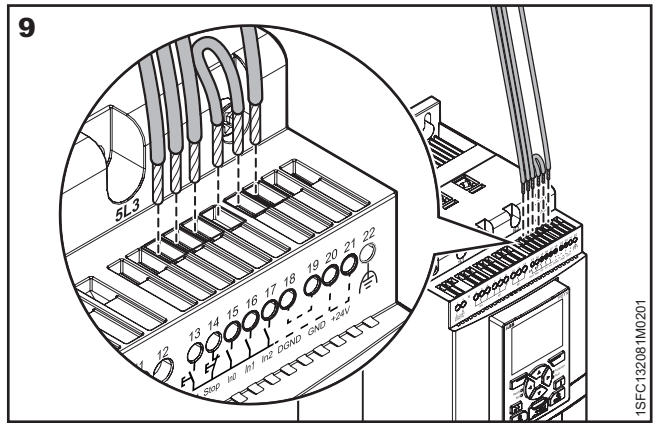

Figure 9: Terminals 15, 16, 17, 18, 19, 20 and 21

Internal control voltage - Push buttons

Connect the cables according to **Figure 10** to use the internal control voltage.

- Connect the blue reset push button as Reset in **Figure 10**
- Connect the black pump cleaning toggle right direction as Forward in **Figure 10**
- Connect the black pump cleaning toggle left direction as Reverse in **Figure 10**

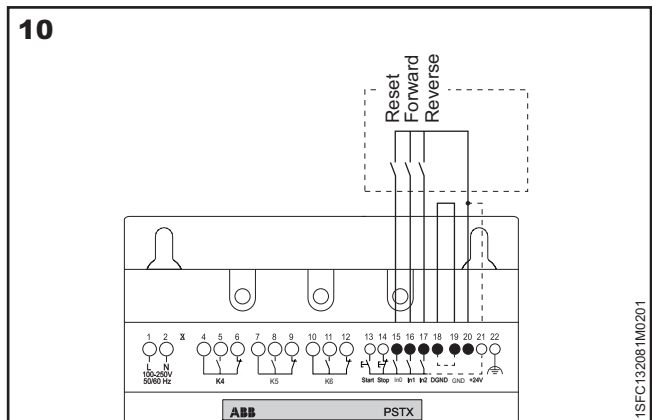

Figure 10: Programmable inputs with internal source used. Typical for push buttons.

Tightening torques and cable dimensions.

	<p>M3 0,5 Nm 4,3 lb.in</p>	<p>3,5 x 0,6 mm (0.138 x 0.024 in)</p>	<p>AWG 12 ... 24 0,2 .. 2,5 mm² 2x0,2 .. 1,5 mm² 0,2 .. 2,5 mm² 2x0,2 .. 1,5 mm²</p>
--	------------------------------------	--	--

External control voltage - PLC

Connect the cables according to **Figure 11** to use an external control voltage.

- Connect PLC control for reset as Reset in **Figure 11**
- Connect PLC control for pump cleaning forward as Forward in **Figure 11**
- Connect PLC control for pump cleaning reverse as Reverse in **Figure 11**



WARNING

Terminal Terminal 13, 14, 15, 16 and 17 should be connected using 24V DC only. Other voltages may damage the softstarter and the warranty may no longer be valid.

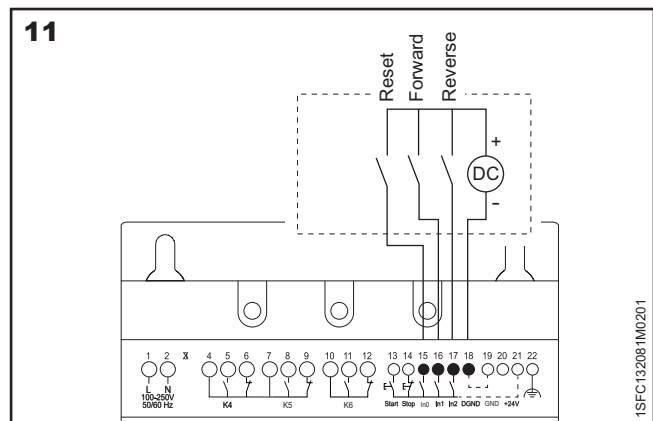

Figure 11: Programmable inputs with external source used. Typical for PLC.

Tightening torques and cable dimensions.

	<p>M3 0,5 Nm 4,3 lb.in</p>	<p>3,5 x 0,6 mm (0.138 x 0.024 in)</p>	<p>AWG 12 ... 24 0,2 .. 2,5 mm² 2x0,2 .. 1,5 mm² 0,2 .. 2,5 mm² 2x0,2 .. 1,5 mm²</p>
--	------------------------------------	--	--

3.2.5 Connecting line contactor and Run pilot light

The output relay gives a signal depending on the selected function. K4 is set to Run by default.

Connect the cables for controlling the line contactor to terminal 4 and 5 for NO control of the contactor.

See **Figure 12**.

Connect the green Run pilot light parallel to the supply voltage for the line contactor, e.g. by using an auxiliary contact block to the line contactor.

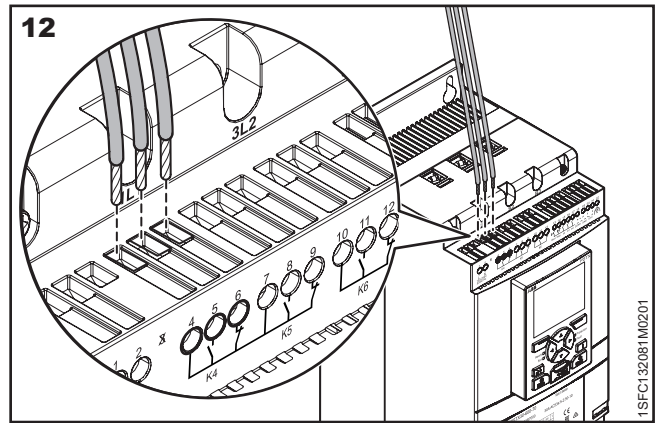

Figure 12: Programmable output relay K4, terminals 4, 5 and 6

Tightening torques and cable dimensions.

	<p>M3,5 0,5 Nm 4,3 lb.in</p>	<p>3,5 x 0,6 mm (0.138 x 0.024 in)</p>	<p>AWG 12 ... 24</p> <p>0,2 .. 2,5 mm² 2x0,2 .. 1,5 mm²</p> <p>0,2 .. 2,5 mm² 2x0,2 .. 1,5 mm²</p>
--	--------------------------------------	--	--

3.2.6 Connecting Event pilot light

The output relay gives a signal depending on the selected function. K6 is set to Event by default.

Connect the cables for the yellow Fault and Protection pilot light to terminal 10 and 11 for NO control of the pilot light. See **Figure 13**.

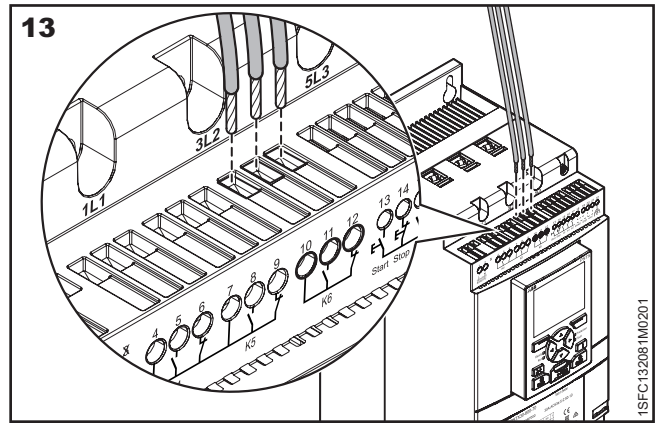

Figure 13: Programmable output relay K6, terminals 10, 11 and 12

Tightening torques and cable dimensions.

	<p>M3 0,5 Nm 4,3 lb.in</p>	<p>3,5 x 0,6 mm (0.138 x 0.024 in)</p>	<p>AWG 12 ... 24</p> <p>0,2 .. 2,5 mm² 2x0,2 .. 1,5 mm²</p> <p>0,2 .. 2,5 mm² 2x0,2 .. 1,5 mm²</p>
--	------------------------------------	--	--

3.2.7 Extension I/O for extra inputs and outputs (optional)

If more inputs and outputs are needed, connect accessory DX111-FBP.0 (1SAJ611000R0101) from ABB.

This will give additional:

- 8 digital input
- 4 output relay
- 1 analog output

The cables shall be connected to terminals 23, 24, 28 and 30. See **Figure 14**.

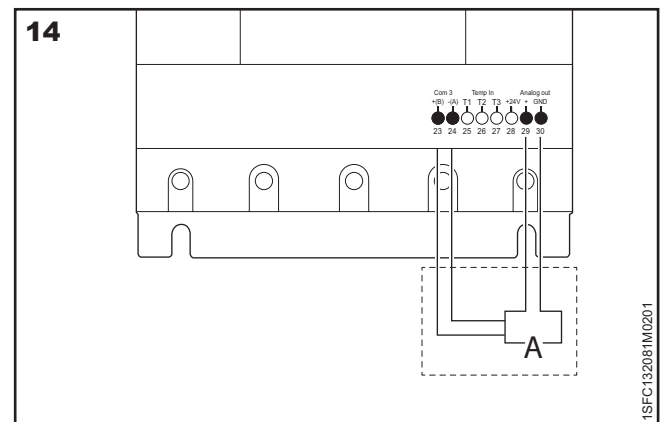

Figure 14: Extension I/O

Tightening torques and cable dimensions.

	<p>M3 0,5 Nm 4,3 lb.in</p>	<p>3,5 x 0,6 mm (0.138 x 0.024 in)</p>	<p>AWG 12 ... 24</p> <p>0,2 .. 2,5 mm² 2x0,2 .. 1,5 mm²</p> <p>0,2 .. 2,5 mm² 2x0,2 .. 1,5 mm²</p>
--	------------------------------------	--	--

4 Set-up

4.1 Navigation

This chapter describes how to set-up the PSTX softstarter according to the recommendation for a waste water pump.

For a complete list of settings and more details about how to set up the softstarter, please see The Installation and commissioning manual (1SFC132081M0201) available on <http://new.abb.com/low-voltage/products/softstarters>.

All parameters are available under Complete list in the Parameters menu.

The set-up of a waste water pump is done in three steps.

1. The basic set-up to set rated current, language and time, **see chapter 4.2 Basic Set-up and application Set-up**
2. Application set-up to set up the softstarter for a centrifugal pump, **see chapter 4.3 Application set-up**
3. Recommended change of parameter values for a waste water pump, **see chapter 4.4 Recommended change of parameter values**

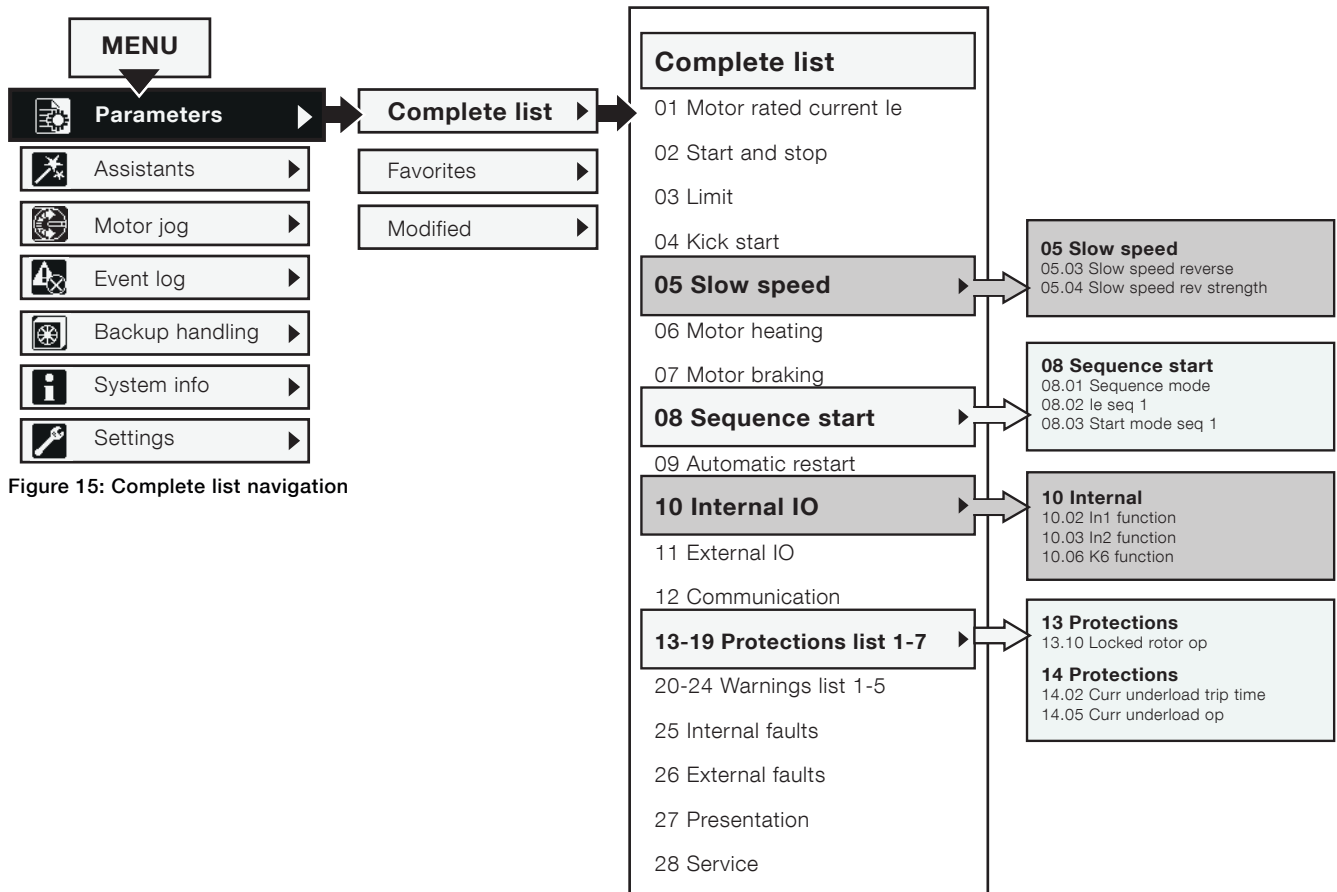

Figure 15: Complete list navigation

4.2 Basic Set-up and application Set-up

Path in menu:

Menu ▶ Assistants

For navigation, see **Figure 16**.

For more details on how to set Basic set-up, Application set-up or more information about Assistants and Application list, see 1SFC132081M0201 - Softstarters Type PSTX30...PSTX370, Installation and Commissioning Manual available on: <http://new.abb.com/low-voltage/products/softstarters>

The Assistants menu contains predefined settings and parameters. This should be used if an easy and quick setup is required. Only a few parameters have to be set before a start of the motor is possible. All necessary input data will show up in an automatic loop. The Assistants menu is divided in:

- **Basic set-up**
- **Application set-up**



INFORMATION

After selecting an application and performing the desired setting, the application should not be selected again. If this is done, all the settings will be reset to the default settings for the selected application.

Enter the Assistants menu

Find the Assistants menu by pressing “Menu” and select Assistants with the Navigation keys. Press “Select” to enter the Assistants menu.

Basic set-up

Use the Navigation keys to select Basic set-up. Press “Select” to enter the Basic set-up. The Basic set-up menu is divided in 5 steps: Language, Date and time, Motor data, System configuration and Setup complete.

4.3 Application set-up

The Application set-up are quick settings for Applications, Values and Tune settings.

Use the Navigation keys to select Application set-up.

Press “Select” to enter the Application set-up.

Select what type of application the softstarter is used for by pressing “Select”.

See **Figure 17**.

For set-up of a typical waste water pump, choose **Centrifugal pump** and change settings to **Recommended values**.

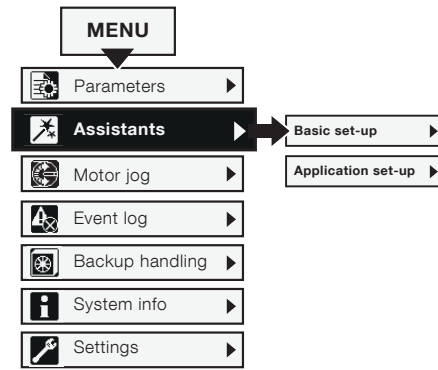

Figure 16: Assistants navigation

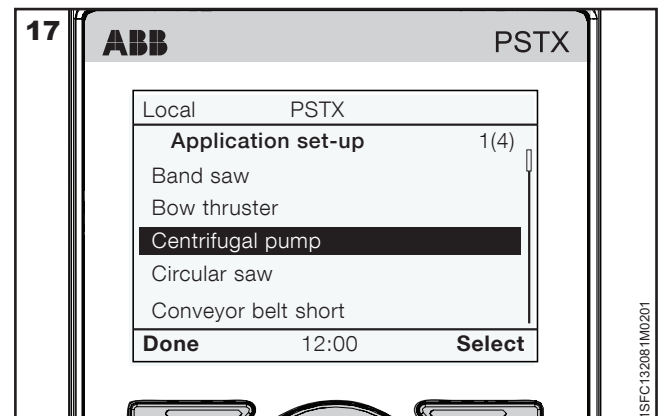

Figure 17: Application set-up

4.4 Recommended change of parameter values

This chapter describes the recommended parameter values. For more information about the parameters for the PSTX softstarter see: **1SFC132081M0201 - Softstarters Type PSTX30...PSTX370, Installation and Commissioning Manual.**

4.4.1 05 Slow speed (pump cleaning reverse)

Menu ▶ Parameters ▶ Complete list ▶ 05 Slow speed

See **Figure 15** for navigation.

These are the recommended settings for Slow speed:

1. Set the parameter 05.03 **Slow speed reverse** to **Fast Jog**
2. Set the parameter 05.04 **Slow speed reverse strength** to **100%**

Parameters:

Parameter	Description	Setting range	Default value	Recommended Value
05.03 Slow speed reverse	Sets the speed of the Pump cleaning reverse. It should be set to the maximum speed, which is 33% or the nominal motor speed.	Fast jog, Jog, Creep	Jog	Fast jog
05.04 Slow speed rev strength	Sets the torque for Pump cleaning reverse. It should be set to the highest possible, which is 100%.	10 ... 100%	50%	100%

4.4.2 08 Sequence start (pump cleaning forward)

Menu ▶ Parameters ▶ Complete list ▶ 08 Sequence start

See **Figure 15** for navigation.

These are the recommended settings for Sequence start:

1. Set the parameter 08.01 **Sequence mode** to **Start several motors**
2. Set the parameter 08.02 **le seq 1** to **Rated current of the motor**
3. Set the parameter 08.03 **Start mode seq 1** to **Full voltage start**

Parameters:

Parameter	Description	Setting range	Default value	Recommended Value
08.01 Sequence mode	Enables sequence start of motors which is necessary to have different starts for normal soft start of pump and Pump cleaning forward start.	Off, Start several motors	Off	Start several motors
08.02 le seq 1	Sets the nominal current for the motor. For good performance, it is important that the nominal current is set to the correct value. For Inside Delta connection, this parameter shall be set to 58% of the nominal motor current.	Depending on softstarter size	Depending on softstarter size	Rated current of the motor
08.03 Start mode seq 1	Sets the desired start mode for Pump cleaning forward. For maximum effect during the start select full voltage start.	Voltage ramp, Torque ramp, Full voltage start	Voltage ramp	Full voltage start

4.4.3 10 Internal IO (push button and PLC control)

Menu ▶ Parameters ▶ Complete list ▶ 10 Internal IO

See **Figure 15** for navigation

These are the recommended settings for Internal IO:

1. Set the parameter 10.02 **In1 function** to **Start 1**
2. Set the parameter 10.03 **In2 function** to **Slow speed reverse**
3. Set the parameter 10.06 **K6 function** to **Event group 1**

Parameters:

Parameter	Description	Setting range	Default value	Recommended Value
10.02 In1 function	Sets the functionality for In1 (terminal 16). Should be selected to Start 1 to get Pump cleaning forward.	None, Reset, Enable, Slow speed forward, Slow speed reverse, Motor heating, Stand still brake, Start reverse, User defined protection, Emergency mode, Fieldbus disable control, Start 1, Start 2, Start 3	None	Start 1
10.03 In2 function	Sets the functionality for In2 (terminal 17). Should be selected to Slow speed reverse to get Pump cleaning reverse.	Same as In1	None	Slow speed reverse
10.06 K6 function	Sets the functionality of relay K6. Should be set to Event group 1 to be used for signaling overload protection.	None, Run, Top of ramp, Eventgroup 0-6, Sequence 1-3 Run, Sequence 1-3 TOR, Run reverse	Event group 0	Event group 1

4.4.4 13-19 Protections (motor protection and detection of pump clogging)

Menu ▶ Parameters ▶ Complete list ▶ 13 Protections

Menu ▶ Parameters ▶ Complete list ▶ 14 Protections

See figure **Figure 15** for navigation.

These are the recommended settings for Protections:

1. Set the parameter 13.10 **Locked rotor op** to **Stop-Manual**
2. Set the parameter 14.02 **Curr underload trip time** to **1**
3. Set the parameter 14.05 **Curr underload op** to **Stop-Manual**

Parameters:

Parameter	Description	Setting range	Default value	Recommended Value
13.10 Locked rotor op	Enable locked rotor protection that protects the motor from overheating when jammed.	Off, Stop-Manual, Stop-Automatic, Indication	Off	Stop-Manual
14.02 Curr underload trip time	Sets the time that the current has to be below the trip level to trip.	0 ... 10 s	10 s	1
14.05 Curr underload op	Enable underload protection that protects the pump from running dry.	Off, Stop manual, Stop auto, Indication	Off	Stop-Manual

Instead of current underload protection it is possible to set power factor underload protection, parameters 14.06 - 14.10. See **1SFC132081M0201 - Softstarters Type PSTX30...PSTX370, Installation and Commissioning Manual**.

5 User guide

This chapter describes the basic operation of the waste water pump if the control products have been connected and set-up according to this manual.

5.1 Normal operation

Normal operation is used for starting and stopping the pump when no clogging is present.

5.1.1 Soft start the pump

To soft start the pump do one of the following actions, depending on selected set-up:

- Press the white start push button (make sure that remote control is selected on the PSTX HMI)
See **1** in **Figure 18**.
- Give start signal with the PLC (make sure that remote control is selected on the PSTX HMI)
- Press the green start button on the PSTX HMI (make sure local control is selected on the PSTX HMI)
See **11** in **Figure 18**.

5.1.2 Soft stop the pump

To soft stop the pump do one of the following actions, depending on selected set-up:

- Press the black stop button (make sure that remote control is selected on the PSTX HMI)
See **2** in **Figure 18**.
- Give stop signal with the PLC (make sure that remote control is selected on the PSTX HMI).
- Press the red stop button on the PSTX HMI (make sure local control is selected on the PSTX HMI)
See **10** in **Figure 18**.

5.1.3 Emergency stop the pump

If the circuit is connected according to this manual, the emergency stop push button will both open the line contactor and disconnect the power supply to the softstarter.

To emergency stop the pump do the following action:

- Press the red emergency stop push button.
See **5** in **Figure 18**.

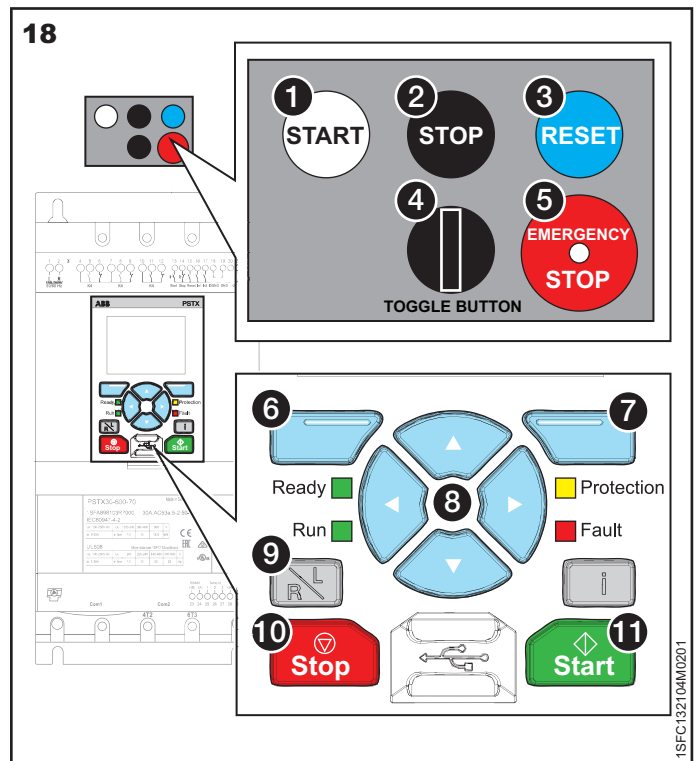

Figure 18: User guide

5.2 When a fault or protection has tripped (Yellow pilot light is on)

When a protection has tripped the softstarter e.g. when the pump is clogged or jammed, the yellow pilot light will turn on and the PSTX HMI display will flash and indicate that a protection is active.

5.2.1 Reset the protection

To reset the protection do one of the following actions, depending on selected set-up:

- Press the blue reset push button (make sure that remote control is selected on the PSTX HMI)
See **3** in **Figure 18**.
- Give Reset signal with the PLC (make sure that remote control is selected on the PSTX HMI)
- Press Options ► Active faults/protections on the PSTX HMI, See **6** in **Figure 18**.

5.2.2 Run manual pump cleaning in reverse direction

To run manual pump cleaning in reverse direction

- Press the black toggle pilot device to the left for reverse pump cleaning (make sure that remote control is selected on the PSTX HMI).
See figure **4** in **Figure 18**.
- Give reverse signal with the PLC (make sure that remote control is selected on the PSTX HMI).
- Press Menu ► Motor jog ► left arrow on the Navigation keypad on the PSTX HMI, See **7** and **8** in **Figure 18**.

5.2.3 Run manual pump cleaning in forward direction

To run manual pump cleaning in forward direction

- Press the black toggle pilot device to the right for forward pump cleaning (make sure that remote control is selected on the PSTX HMI). See figure **4** in **Figure 18**.
- Give forward signal with the PLC (make sure that remote control is selected on the PSTX HMI).

If this solves the clogging, start the pump according to chapter **5.1.1 Soft start the pump**.

5.3 Change between local and remote control

To change control of the PSTX softstarter between local control and remote control, press the L/R button on the PSTX HMI, See **9** in **Figure 18**.

- Local control means control only with the PSTX HMI
- External control means control with either push buttons or PLC.

Contact us

ABB AB
Control Products
Low Voltage Products

SE-721 61 VÄSTERÅS, Sweden

www.abb.com/lowvoltage

Note

We reserve the right to make technical changes or modify the contents of this document without prior notice. With regard to purchase orders, the agreed particulars shall prevail. ABB does not accept any responsibility whatsoever for potential errors or possible lack of information in this document.

We reserve all rights in this document and in the subject matter and illustrations contained therein. Any reproduction, disclosure to third parties or utilization of its contents - in whole or in parts - is forbidden without prior written consent of ABB.

© Copyright 2015. All rights reserved.



To get more information, install QR code reader on your mobile device, scan the code and see more.