

OPTION FOR ABB DRIVES, CONVERTERS AND INVERTERS

LonWorks® FLON-01 adapter module

User's manual

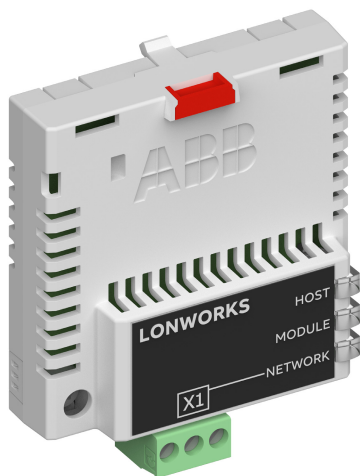

List of related manuals

See section *Related manuals* on page 12.

You can find manuals and other product documents in PDF format on the Internet. See section Document library on the Internet on the inside of the back cover. For manuals not available in the Document library, contact your local ABB representative.

The code below opens an online listing of the manuals applicable to the product:



FLON-01 manual



Fieldbus connectivity webpage

User's manual

LonWorks® FLON-01 adapter module

Table of contents



1. Safety instructions



4. Mechanical installation



5. Electrical installation



6. Start-up



Table of contents

1. Safety instructions

What this chapter contains	9
Use of warnings	9
Safety in installation	10

2. Introduction

What this chapter contains	11
Purpose of the manual	11
Applicability	11
Compatibility	11
Target audience	12
Before you start	12
Related manuals	12
Contents	13
Cyber Security Disclaimer	14
Terms and abbreviations	15



3. Overview of the LONWORKS®

What this chapter contains	17
LONWORKS® system	17
Adapter module	18

4. Mechanical installation

What this chapter contains	21
Necessary tools and instructions	21
Unpacking and examining the delivery	21
Installing the adapter module	22

5. Electrical installation

What this chapter contains	25
Necessary tools and instructions	25
General cabling instructions	26
Connecting the module to the LONWORKS® network	26

2 Table of contents

Terminal block description	26
Bus termination	27
Earthing of the LONWORKS® cable screens	28

6. Start-up

What this chapter contains	29
Drive configuration	30
LONWORKS® connection configuration	30
Control locations	34

7. Communication

What this chapter contains	35
General	35
LonMark® objects	36
Node object	36
Variable speed motor drive object	37
Open loop actuator object: DigitalCommand	39
Open loop sensor object: DigitalStatus	39
Open loop sensor object: DigitalInput	40
Open loop sensor object: DigitalOutput	40
Open loop actuator object: AnalogCmd	40
Open loop sensor object: AnalogStatus	41
Open loop sensor object: AnalogInput	41
Open loop sensor object: AnalogOutput	41
Resource files	42

8. Network variables

What this chapter contains	43
Supported input network variables	43
nviAnlgCmd1 ... nviAnlgCmd8	44
nviCtlOverrideCm	45
nviDigCmd1 ... nviDigCmd12	46
nviDrvProcStpt	46
nviDrvSpeedScale	47
nviDrvSpeedStpt	48
nviEmrgOverride	48
nviExt1Ext2Ctrl	49



nviLocLock	50
nviRequest	50
nviResetFault	51
nviRunEnable	52
nviSavePars	52
nviStartEnable1	53
nviStartEnable2	53
Supported output network variables	54
nvoAccelerating	56
nvoAlarm	58
nvoAnlgInput1 ... nvoAnlgInput8	58
nvoAnlgOutput1 ... nvoAnlgOutput8	59
nvoAnlgSts1 ... nvoAnlgSts8	60
nvoAtReference	61
nvoBypKwh_R	61
nvoBypRunHours	62
nvoBypTemp	63
nvoCtlOverrideSt	64
nvoDecelerating	64
nvoDigInput1 ... nvoDigInput12	65
nvoDigOutput1 ... nvoDigOutput12	66
nvoDigSts1 ... nvoDigSts12	67
nvoDrvCurnt	68
nvoDrvDCBus	69
nvoDrvKwh_NR	70
nvoDrvKwh_R	71
nvoDrvPwr	72
nvoDrvRunHours	72
nvoDrvSpeed	73
nvoDrvTemp	74
nvoDrvTorque	75
nvoDrvVolt	75
nvoEmrgOvrStat	76
nvoEnabled	77
nvoExt1Ext2Stat	77
nvoFaultCode	78



4 Table of contents

nvoFaulted	79
nvoForward	79
nvoFreqAct	80
nvoLimit	81
nvoLineUVolt, nvoLineVWVlt, nvoLineWUVolt	81
nvoLineVolt	82
nvoLocRemStat	83
nvoMtrRevCntM	84
nvoMtrTemp	85
nvoNetCtrl	85
nvoNetRef1	86
nvoNetRef2	87
nvoParReadValue	87
nvoPid1Dev, nvoPid2Dev	88
nvoPid1Fbk, nvoPid2Fbk	89
nvoReady	89
nvoReverse	90
nvoRunning	91
nvoSpeedActRpm	91
nvoStarted	92
nvoStatus	93
nvoZeroSpeed	93
Supported network configuration properties	95
SCPTdefScale / nciDrvSpeedScale	98
SCPTlocation / nciLocation	98
SCPTmaxRcvTime / nciAnlgRcvHrtBt	99
SCPTmaxRcvTime / nciDigRcvHrtBt	99
SCPTmaxRcvTime / nciVsmdRcvHrtBt	100
SCPTmaxSendTime / nciAnlgSndHrtBt	100
SCPTmaxSendTime / nciDigSndHrtBt	101
SCPTmaxSendTime / nciVsmdSndHrtBt	102
SCPTmaxSetpoint / nciMaxSpeed	102
SCPTminSendTime / nciAnlgMinOutTm	103
SCPTminSendTime / nciDigMinOutTm	104
SCPTminSendTime / nciVsmdMinOutTm	104
SCPTminSetpoint / nciMinSpeed	105



SCPTnomFreq / nciNmIFreq	105
SCPTnomRPM / nciNmISpeed	106
SCPTrampDownTm / nciRampDownTm	106
SCPTrampUpTm / nciRampUpTm	107
UCPTbypRunDelay / nciBypRunDelay	107
UCPTdrvCurntLimit / nciDrvCurntLimit	108
UCPTparReadIndex / nciParReadIndex	108
UCPTparValue / nciParWriteValue	109
UCPTparWriteIndex / nciParWriteIndex	109
UCPTpid1DerFiltTime / nciPid1DerFiltTi,	
UCPTpid2DerFiltTime / nciPid2DerFiltTi	110
UCPTpid1DerTime / nciPid1DerTime,	
UCPTpid2DerTime / nciPid2DerTime	110
UCPTpid1Gain / nciPid1Gain, UCPTpid2Gain / nciPid2Gain	111
UCPTpid1IntTime / nciPid1IntTime,	
UCPTpid2IntTime / nciPid2IntTime	112
UCPTstopLevel / nciStopLevel	112
UCPTstopMode / nciStopMode	113



9. Diagnostics

What this chapter contains	115
Fault and warning messages	115
LED indications	116

10. Technical data

What this chapter contains	117
FLON-01	118
LonWorks® network	119
LonWorks® network cable specifications	119
LonWorks® network, maximum bus lengths	121

11. Appendix – Compatibility table

What this chapter contains	123
Supported network variables in alphabetical order	123

Further information

6 *Table of contents*



1

Safety instructions

What this chapter contains

The chapter contains the warning symbols used in this manual and the safety instructions which you must obey when you install or connect an optional module to a drive, converter or inverter. If you ignore the safety instructions, injury, death or damage can occur. Read this chapter before you start the installation.



Use of warnings

Warnings tell you about conditions which can cause injury or death and, or damage to the equipment. They also tell you how to prevent the danger. The manual uses these warning symbols:



Electricity warning tells you about hazards from electricity which can cause injury or death, or damage to the equipment.



General warning tells you about conditions, other than those caused by electricity, which can cause injury or death, or damage to the equipment.

Safety in installation

These instructions are for all who install or connect an optional module to a drive, converter or inverter and need to open its front cover or door to do the work.



WARNING! Obey these instructions. If you ignore them, injury or death, or damage to the equipment can occur.



- If you are not a qualified electrician, do not do installation or maintenance work.
 - Disconnect the drive, converter or inverter from all possible power sources. After you have disconnected the drive, converter or inverter, always wait for 5 minutes to let the intermediate circuit capacitors discharge before you continue.
 - Disconnect all dangerous voltages connected to other control signal connectors in reach. For example, it is possible that 230 V AC is connected from outside to a relay output of the drive, converter or inverter.
 - Always use a multimeter to make sure that there are no parts under voltage in reach. The impedance of the multimeter must be at least 1 Mohm.
-

2

Introduction

What this chapter contains

This chapter introduces this manual.

Purpose of the manual

The manual provides information on installing, commissioning and using LONWORKS® FLON-01 adapter module.

Applicability

This manual applies to the FLON-01 adapter module, SW version 2.01 or later.

Compatibility

The adapter module interoperates with all LONWORKS® devices.

Note: LONWORKS® supports a variety of media. The adapter module supports TP/FT-10 media. A LONWORKS® router would be required for the adapter module to interoperate with devices on other media.

For drive-specific network variables, see chapter [Appendix – Compatibility table](#) on page 123.

Target audience

This manual is intended for people who plan the installation, install, start up, use and service the adapter module. Before you do work on the module, read this manual and the applicable drive manual that contains the hardware and safety instructions for the product in question.

You are expected to know the fundamentals of electricity, wiring, electrical components and electrical schematic symbols.

The manual is written for readers worldwide. Both SI and imperial units are shown.

Before you start

It is assumed that the drive is installed and ready to operate before you start the installation of the adapter module.

In addition to conventional installation tools, have the drive manuals available during the installation as they contain important information not included in this manual. The drive manuals are referred to at various points of this manual.

Related manuals

The related manuals are listed below.

Drive hardware manuals and guides	Code (EN)
<i>ACQ810 manuals</i>	00598718
<i>ACS850-04 manuals</i>	00592009
<i>ACS355 drives (0.37...22 kW, 0.5...30 hp) user's manual</i>	3AUA0000066143
<i>ACH580-01 manuals</i>	9AKK10103A0587
<i>ACH580-04 manuals</i>	9AKK106930A9059
<i>ACH580-07 manuals</i>	9AKK106930A5241
Option manuals and guides	
<i>FLON-01 LONWORKS® adapter module user's manual</i>	3AUA0000041017

Contents

The manual consists of the following chapters:

- *Safety instructions* contains the safety instructions which you must follow when installing a fieldbus adapter module.
 - *Introduction* introduces this manual.
 - *Overview of the LONWORKS®* contains a short description of the LONWORKS® and the adapter module, and a delivery checklist.
 - *Mechanical installation* contains a delivery checklist and instructions to install the adapter module.
 - *Electrical installation* contains cabling and bus termination instructions and instructions on connecting the module to the LONWORKS® network.
 - *Start-up* presents the steps to take during the start-up of the drive with the adapter module.
 - *Communication* describes the operation of the adapter module on a LONWORKS® network.
 - *Network variables* describes the network variable list of the adapter module.
 - *Diagnostics* explains how to trace faults with the status LEDs on the adapter module.
 - *Technical data* contains the technical data of the adapter module and the DeviceNet link.
 - *Appendix – Compatibility table* lists the network variables that are used with the drives compatible with the adapter module.
-

Cyber Security Disclaimer

This product is designed to be connected to and to communicate information and data via a network interface. It is Customer's sole responsibility to provide and continuously ensure a secure connection between the product and Customer network or any other network (as the case may be). Customer shall establish and maintain any appropriate measures (such as but not limited to the installation of firewalls, application of authentication measures, encryption of data, installation of anti-virus programs, etc.) to protect the product, the network, its system and the interface against any kind of security breaches, unauthorized access, interference, intrusion, leakage and/or theft of data or information. ABB and its affiliates are not liable for damages and/or losses related to such security breaches, any unauthorized access, interference, intrusion, leakage and/or theft of data or information.

Note: The web pages are meant only for configuring the device during commissioning. For security reasons, it is recommended to disable the web pages after commissioning.

Terms and abbreviations

Term / Abbreviation	Explanation
Command word	See <i>Control word</i> .
Communication module	Communication module is a name for a device (eg, a fieldbus adapter) through which the drive is connected to an external communication network (eg, a fieldbus). The communication with the module is activated with a drive parameter.
Control word	16-bit or 32-bit word from master to slave with bit-coded control signals (sometimes called the Command word).
CRC	Cyclic redundancy check.
FLON-01	A device through which an ABB drive is connected to a FLON-01 LONWORKS [®] network.
Function profile	Functional profiles may contain one or more objects that interact to perform the required profile defined operability. The Variable Speed Motor Drive Profile contains the general LONWORKS [®] Node Object, application-specific Variable Speed Motor Drive Object, and the Open Loop Sensor and Open Loop Actuator objects.
LonMark [®]	Products that conform to LonMark [®] Interoperability Guidelines, defined by the LonMark [®] Interoperability Association, are eligible to carry the LonMark [®] logo.
LonTalk [®]	The communication protocol in LONWORKS [®] networks.
LSB	Least significant bit
MSB	Most significant bit
NCI	Network configuration variable
Neuron [®] ID	Every LONWORKS [®] device or – as synonym – node must have a unique ID. This is called the Neuron [®] ID. This ID is, on Neuron [®] Chip-based nodes, stored in the chip itself and cannot be changed.

Term / Abbreviation	Explanation
NV	Network variable
NVI	Input network variable
NVO	Output network variable
Object	An object is a set of one or more network variables implemented as SNVTs with semantic definitions relating the behaviour of the object to the network variable values, in addition to a set of configuration properties. For example, the Variable Speed Motor Drive Object and the Node Object represent two types of objects.
Parameter	Operating instruction for the drive. Parameters can be read and programmed with the drive control panel, drive PC tools or through the adapter module.
Service pin	The Service Pin is used in installing the node. Pressing the Service Pin causes the LONWORKS® node to send the so-called Service Pin Message which includes, among other things, the Neuron® ID. This informs the network or installation tool about the node. Holding the Service Pin for more than 10 seconds forces the module to "Go Unconfigured".
SNVT	Standard network variable type.
UCPT	User configuration property type.

3

Overview of the LONWORKS®

What this chapter contains

This chapter contains a short description of the LONWORKS® network and the FLON-01 adapter module.

LONWORKS® system

The LONWORKS® system is an open serial communication solution that enables data exchange between all kinds of automation components.

A LONWORKS® network consists of intelligent devices, called nodes, connected by one or more communications media that communicate with one another using the LonTalk® protocol. A LONWORKS® network can consist of up to 32385 nodes divided into 255 subnets (127 nodes/subnet). Nodes are programmed to send messages to one another in response to external events or messages they receive. Each intelligent device, for example a programmable thermostat in a building control system, is a LONWORKS® node. A node is connected to other nodes with appropriate communications media, such as twisted pair cable, RF link, or power line circuit.

Each node includes a physical interface, transceiver, that interfaces with the communication media. The adapter module uses the FT-X1 Free Topology Transceiver (compatible with the FTT-10A transceiver) from Echelon Corporation. This commonly used twisted-pair media supports star, bus, and loop wiring. The FT-X1 transceiver connects to a twisted pair cable with a baud rate

of 78 kbit/s and appears as high impedance to the network when unpowered, hence it does not interfere with the network communications when powered down.

LONWORKS® nodes are objects that respond to various inputs and that produce desired outputs. Connecting the inputs and outputs of these network objects enables the network to perform specific tasks.

While the function of any particular node may be quite simple, the interaction among nodes enables a LONWORKS® network to perform complex tasks. A benefit of LONWORKS® networks is that a small number of common node types may perform a broad spectrum of different functions depending on how they are configured and connected.

Adapter module

The adapter module is an optional device which enables the connection of an ABB drive to a LONWORKS® network. See the figure below on the adapter module and the construction of the network. Through the adapter module, it is possible to:

- give control commands to the drive (Start, Stop, Run enable, etc)
- feed a motor speed or frequency reference to the drive
- give a process actual value or a process reference to the PID controller of the drive
- read status information and actual values from the drive
- change drive parameter values
- reset a drive fault
- control other LONWORKS® nodes.

The network variables and functions supported by the adapter module are discussed in chapters [Start-up](#), [Communication](#) and [Network variables](#).

The adapter module is mounted into an option slot on the motor control board of the drive. See the drive documentation for module placement options.

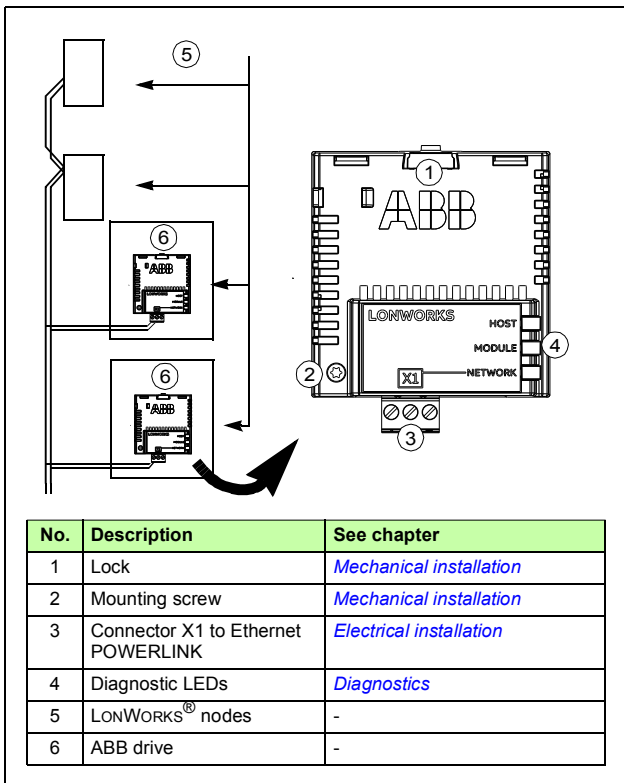

4

Mechanical installation

What this chapter contains

This chapter contains a delivery checklist and instructions to install the adapter module.

Necessary tools and instructions

You will need a Torx TX10 screwdriver to secure the FLON adapter module to the drive. See also, the applicable drive hardware manual.



Unpacking and examining the delivery

1. Open the option package.
 2. Make sure that the package contains:
 - LONWORKS[®] adapter module, type FLON-01
 - this manual.
 3. Make sure that there are no signs of damage.
-

Installing the adapter module



WARNING! Obey the safety instructions. See chapter [Safety instructions](#) on page 9. If you ignore the safety instructions, injury or death can occur.

The adapter module has a specific position in the drive. You can plug and unplug the adapter when the drive is power off and no external 24 voltage supplied to the control board. Plastic pins, a lock and one screw to hold the adapter module in place. The screw also makes an electrical connection between the module and drive frame for cable shield termination.

When the adapter module is installed, it makes the signal and power connection to the drive through a 20-pin connector.

When you install or remove the adapter module from the control unit:

1. Pull out the lock.

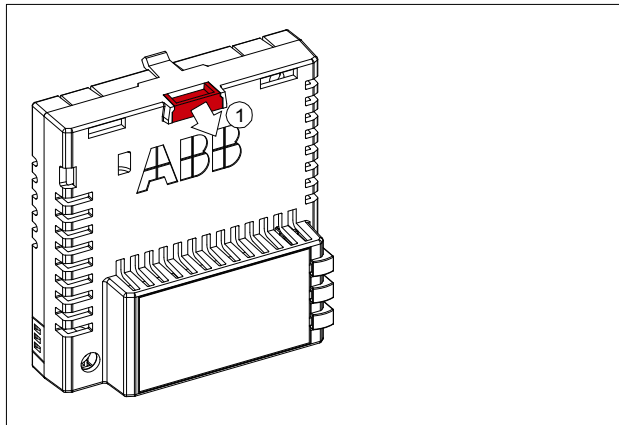

- Put the adapter module carefully into its position on the drive.
- Push in the lock.

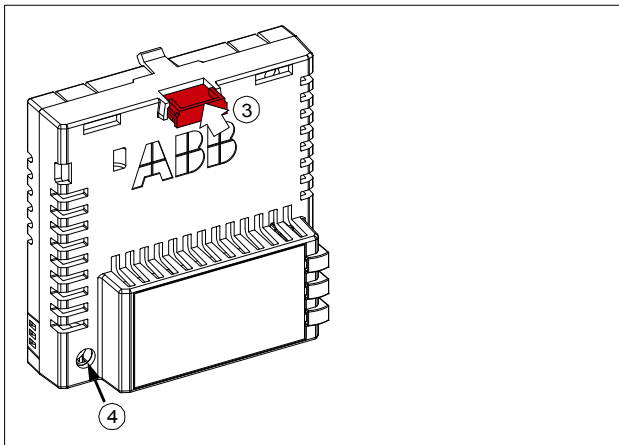

- Tighten the screw to torque 0.8 N·m using a Torx TX10 screwdriver.

Note: A too high torque may break the screws. It is necessary to tighten the screw properly to fulfill the EMC requirements and to ensure the proper operation of the module.

See the applicable drive manual for further instructions on how to install the adapter module to the drive.





5

Electrical installation

What this chapter contains

This chapter contains:

- general cabling instructions
- instructions on connecting the module to the LONWORKS® network
- instructions on switching on the bus termination.



WARNING! Obey the safety instructions. See chapter [Safety instructions](#) on page 9. If you ignore the safety instructions, injury or death can occur. If you are not a qualified electrician, do not do electrical work.



Necessary tools and instructions

See the applicable drive hardware manual.

General cabling instructions

- Arrange the bus cables as far away from the motor cables as possible.
- Avoid parallel runs.
- Use bushings at cable entries.

Connecting the module to the LONWORKS® network

Connect the bus cable to terminal block X1 on the adapter module.

■ Terminal block description

X1		Description
1	SHLD	RC-filtered connection to the module ground
2	NET A	Network Connection A ¹⁾
3	NET B	Network Connection B ¹⁾

¹⁾ For the LONWORKS® TP/FT-10 topology, either network connection may be connected to either pin.



Bus termination

The bus line is terminated with resistors connected between the network cable conductors A and B when the adapter module is at the end of the bus. Termination prevents signal reflections from the bus cable ends. See the figure below on the bus termination for different network topologies.

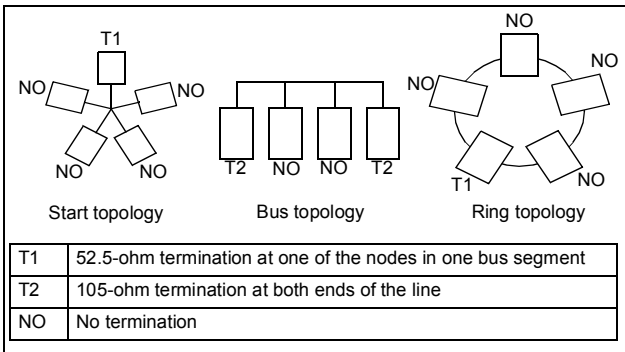

Earthing of the LONWORKS[®] cable screens

The LONWORKS[®] cable screen can be directly earthed at one station only. At other stations the screen should be earthed via RC filter. See the below figure on the network cable connection for the bus topology.

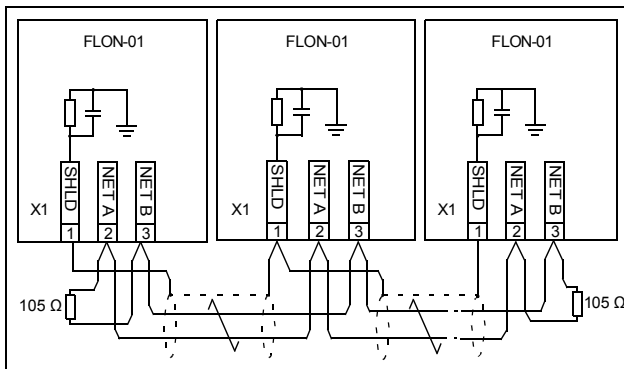

6

Start-up

What this chapter contains

This chapter contains:

- information on configuring the drive for operation with the adapter module
- drive-specific instructions on starting up the drive with the adapter module

Note: The adapter module cannot control the drive before it is configured for the LONWORKS[®] network. The LONWORKS[®] communication configuration does not require parametrization of the drive. The LONWORKS[®] network is configured using a network installation tool. Refer to the installation tool documentation for network configuration and to chapter [Communication](#) on page 35 for the resource files.



WARNING! Obey the safety instructions given in this manual and the drive documentation.

Drive configuration

■ LONWORKS® connection configuration

After the adapter module has been mechanically and electrically installed according to the instructions in chapters [Mechanical installation](#) and [Electrical installation](#), the drive must be prepared for communication with the module.

The adapter module reads several parameter values from the drive to operate correctly and to select different modes. Furthermore, some of the configuration network variable values receive their defaults from the drive. The drive control location parameters should also be set accordingly to enable full and logical operation of the adapter module. See [Control locations](#). For more information on configuring the drive, refer to the drive documentation.

Information parameters of the adapter module		
Fieldbus par no.	Parameter name	Description
1	MODULE TYPE	Type of the module (LonWorks)
2	NODE STATE	State of the adapter module
3-8	NEURON ID [5...0]	Neuron® chip ID
9	NODE ADDRESS 1	ID of the node within this subnet
10	NODE SUBNET 1	Subnet (1) to which the node belongs
11-16	DOMAIN ID 1 [4...0]	Domain ID in a LonWorks network
17	NODE ADDRESS 2	ID of the node within this subnet
18	NODE SUBNET 2	Subnet (2) to which the node belongs
19-24	DOMAIN ID 2 [4...0]	ID in a LonWorks network
25	XMIT ERRORS	Number of CRC errors
26	TRANS TIMEOUTS	Number of transmission failures

Note: These parameters become visible in the drive only after the adapter module has been configured on the network side.

MODULE TYPE

This parameter shows the module type as detected by the drive.

The value cannot be adjusted by the user. (If this parameter is undefined, the communication between the drive and the module has not been established.)

NODE STATE

This parameter contains the current state of the network interface. Configured on-line is the normal run-time mode and means that the node is commissioned and on-line on the network.

Soft/Bypass¹⁾/Hard off-line means that the node is not participating actively on the network.

The byte has the following bit assignments:

B	x	x	x	M	S	S	S
---	---	---	---	---	---	---	---

Where:

- B = bypass¹⁾
- x = not used
- M = mode
- S = state

Bxx	MSSS	State
xxxx	x011	Unconfigured – without application
xxxx	x010	Unconfigured – with application
xxxx	x110	Configured – hard offline
0xxx	1100	Configured – soft offline
1xxx	1100	Configured – bypass offline ¹⁾
2xxx	0100	Configured – online

¹⁾not for generic drive use



NEURON ID

This parameter displays the Neuron® chip ID of the module in decimal format. The ID is determined by the chip and cannot be changed.

- Par. 3: NEURON ID [5] = byte 6 of the unique Neuron ID (MSB)
- Par. 4: NEURON ID [4] = byte 5 of the unique Neuron ID
- Par. 5: NEURON ID [3] = byte 4 of the unique Neuron ID
- Par. 6: NEURON ID [2] = byte 3 of the unique Neuron ID
- Par. 7: NEURON ID [1] = byte 2 of the unique Neuron ID
- Par. 8: NEURON ID [0] = byte 1 of the unique Neuron ID (LSB)

The decimal values of the parameters are converted to Neuron ID as shown by the following example:

- Parameter 3 = 4 = 04h
- Parameter 4 = 118 = 76h
- Parameter 5 = 213 = D5h
- Parameter 6 = 244 = F4h
- Parameter 7 = 1 = 01h
- Parameter 8 = 0 = 00h

These decimal parameter values yield a Neuron ID of 0476D5F40100h.



NODE ADDRESS 1

This parameter indicates the ID of the node within the subnet.

Range

1 - 127 (0 = node address 1 not assigned).

NODE SUBNET 1

This parameter indicates to which subnet the node belongs.

Range

1 - 255 (0 = node subnet 1 not assigned).

DOMAIN ID 1

This parameter indicates the ID of the domain within this subnet. Each domain in a LonWorks® network has a unique ID of 0, 1, 3 or 6 bytes in length. If the ID is shorter than 6 bytes, it is left justified in this field.

- DOMAIN ID 1 [5] = byte 6 of the domain ID (MSB)
- DOMAIN ID 1 [4] = byte 5 of the domain ID
- DOMAIN ID 1 [3] = byte 4 of the domain ID
- DOMAIN ID 1 [2] = byte 3 of the domain ID
- DOMAIN ID 1 [1] = byte 2 of the domain ID
- DOMAIN ID 1 [0] = byte 1 of the domain ID (LSB)

NODE ADDRESS 2

This parameter indicates the ID of the node within this subnet.

Range

1 - 127 (0 = node address 2 not assigned).

NODE SUBNET 2

This parameter indicates to which subnet the node belongs.

Range

1 - 255 (0 = node subnet 2 not assigned).

DOMAIN ID 2

This parameter indicates the ID of the domain within this subnet. Each domain in a LonWorks® network has a unique ID of 0,1,3 or 6 bytes in length. If the ID is shorter than 6 bytes, it is left justified in this field.

- DOMAIN ID 2 [5] = byte 6 of the domain ID (MSB)
- DOMAIN ID 2 [4] = byte 5 of the domain ID
- DOMAIN ID 2 [3] = byte 4 of the domain ID
- DOMAIN ID 2 [2] = byte 3 of the domain ID
- DOMAIN ID 2 [1] = byte 2 of the domain ID
- DOMAIN ID 2 [0] = byte 1 of the domain ID (LSB)



XMIT ERRORS

This parameter indicates the number of CRC errors detected during packet reception. An increasing value may be due to collisions or noise on the transceiver input.

TRANS TIMEOUTS

This parameter indicates the number of times that the node failed to receive expected acknowledgements or responses after retrying configuring number of times. An increasing value may be due to destination nodes being inaccessible on the network, transmission failures because of noise on the channel, or if any destination node has insufficient buffers or receive transaction records.

Control locations

ABB drives can receive control information from multiple sources including digital inputs, analogue inputs, the drive control panel and a communication module (eg, adapter module). ABB drives allow the user to separately determine the source for each type of control information (Start, Stop, Direction, Reference, Fault Reset, etc). To give the fieldbus master station the most complete control over the drive, the communication module must be selected as source for this information. See the user documentation of the drive for information on the selection parameters.





Communication

What this chapter contains

This chapter describes the communication profiles used in the communication between the DeviceNet network, the adapter module and the drive.

General

In LONWORKS[®] networks, the network design emphasis is on designing the network variable connections. The connection design determines the amount of data flow between different nodes, thus determining the decision of transmission media and network topology overall in the network.

In designing the connections, the selection of protocol services is also crucial when determining the network data flow. By default, the network connections use acknowledged messaging with a certain retry count. This can, however, be changed by the installation tool to optimize the overall network performance.

To be able to realize the required operation of the whole system, a clear picture of the capabilities of individual nodes is needed. These capabilities are determined by the network variables.

LONMARK[®] objects

The adapter module includes a node object, a drive object and several open loop sensor or actuator objects. The node object is used to control the drive object. The drive object realizes the LONMARK[®] Functional Profile: 'Variable Speed Motor Drive Version', 1.1. The profile defines a set of network variables and configuration properties. In addition, the drive object includes a set of manufacturer defined network variables and configuration properties that are defined to realize functions only applicable for ABB drives.

The network variables and configuration properties included by the node, drive and open loop sensor/actuator objects are detailed in chapter [Network variables](#) on page 43.

■ Node object

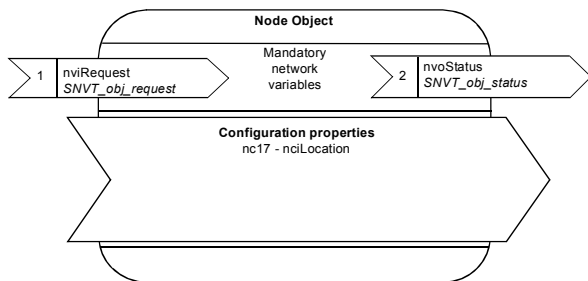

Variable speed motor drive object

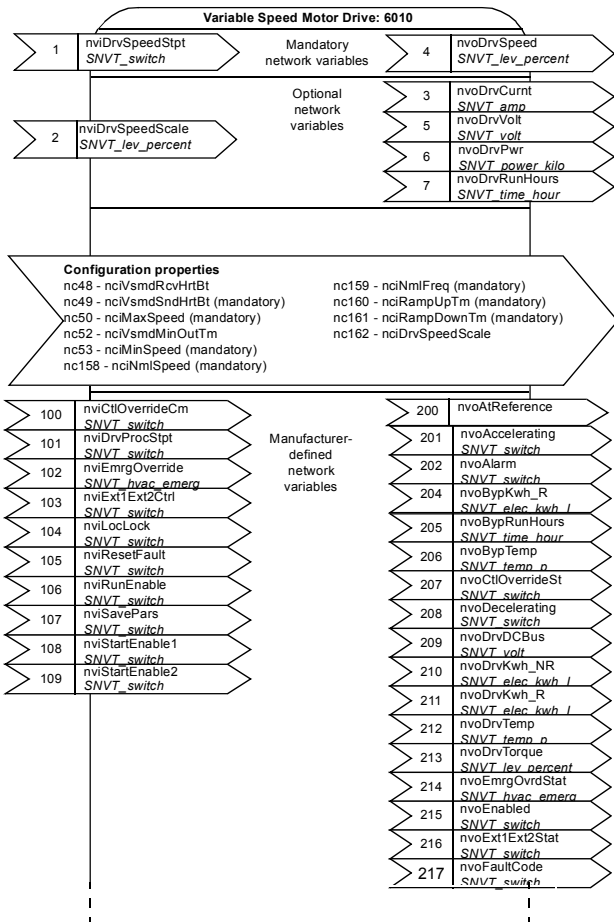

Manufacturer-
defined
network
variables

218	nvoFaulted <i>SNVT_switch</i>
219	nvoForward <i>SNVT_switch</i>
220	nvoFreqAct <i>SNVT_freq_hz</i>
221	nvoLimit <i>SNVT_switch</i>
222	nvoLineVolt <i>SNVT_volt</i>
223	nvoLineUVVolt <i>SNVT_volt</i>
224	nvoLineVWVolt <i>SNVT_volt</i>
225	nvoLineWUVolt <i>SNVT_volt</i>
226	nvoLocRemStat <i>SNVT_switch</i>
227	nvoMtrRevCntM <i>SNVT_count_32</i>
228	nvoMtrTemp <i>SNVT_temp_p</i>
229	nvoNetCtrl <i>SNVT_switch</i>
230	nvoNetRef1 <i>SNVT_switch</i>
231	nvoNetRef2 <i>SNVT_switch</i>
232	nvoParReadValue <i>SNVT_count</i>
233	nvoPid1Dev <i>SNVT_lev_percent</i>
234	nvoPid1Fbk <i>SNVT_lev_percent</i>
235	nvoPid2Dev <i>SNVT_lev_percent</i>
236	nvoPid2Fbk <i>SNVT_lev_percent</i>
237	nvoReady <i>SNVT_switch</i>
238	nvoReverse <i>SNVT_switch</i>
239	nvoRunning <i>SNVT_switch</i>
240	nvoSpeedActRpm <i>SNVT_count_inc</i>
241	nvoStarted <i>SNVT_switch</i>
242	nvoZeroSpeed <i>SNVT_switch</i>

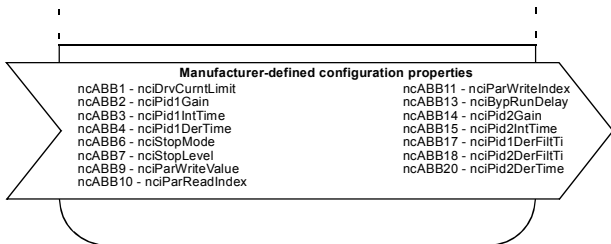

Open loop actuator object: DigitalCommand

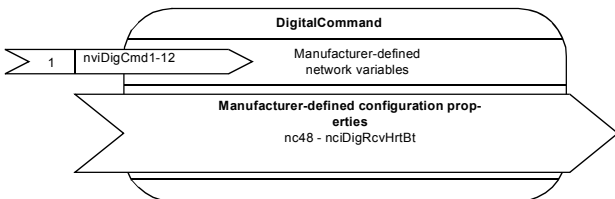

Open loop sensor object: DigitalStatus

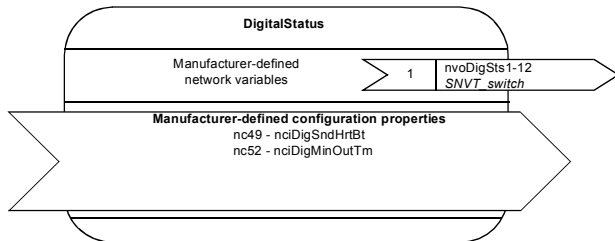

Open loop sensor object: DigitalInput

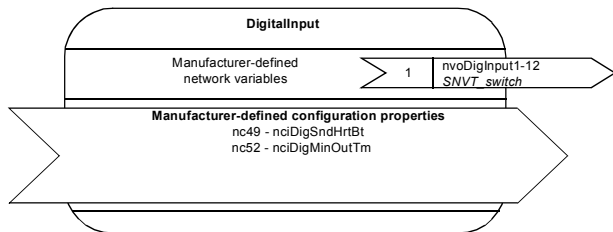

Open loop sensor object: DigitalOutput

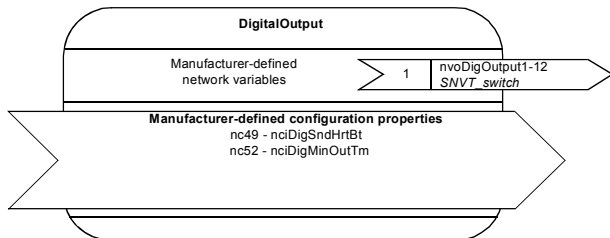

Open loop actuator object: AnalogCmd

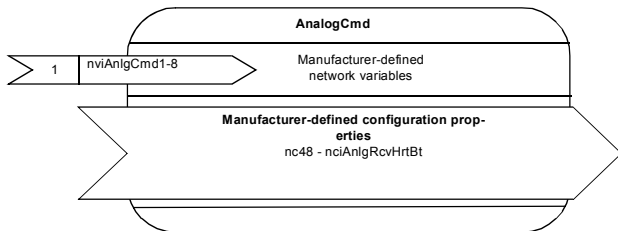

■ Open loop sensor object: AnalogStatus

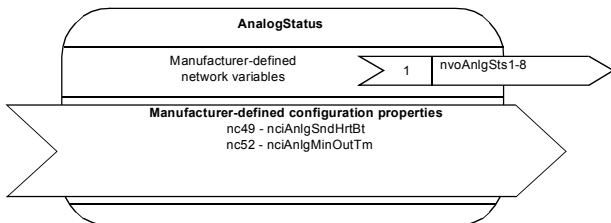

■ Open loop sensor object: AnalogInput

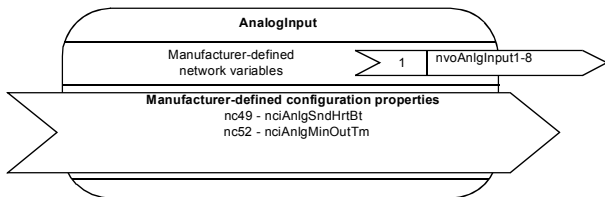

■ Open loop sensor object: AnalogOutput

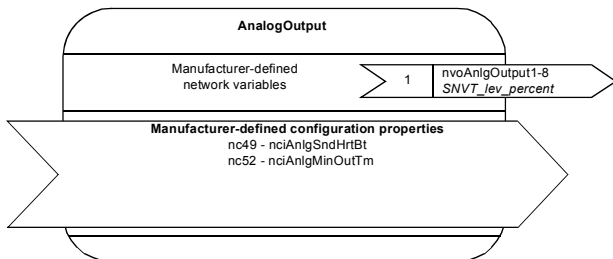

Resource files

For the installation of the adapter module with different installation tools, resource files are needed. If you have not received these files together with the adapter module, consult your local ABB representative or ABB's web site.

The resource files are delivered as a compressed (*.ZIP) archive. Copy the ZIP archive to your "LonWorks" directory and unpack the compressed files.

The directory **LONWORKS\TYPES\USER\ABB\FLON** holds the user type and enumeration file (VSD_FLON01.TYP), the user type formatting file (VSD_FLON01.FMT), the functional profile template file (VSD_FLON01.FPT) and the language file (VSD_FLON01.ENU).

The directory **LONWORKS\IMPORT\ABB\FLON** holds the external interface files (*.XIF):

- XIF version 2.0 (e.g. FLON_V20.XIF)
- XIF version 3.1 (e.g. FLON_V31.XIF)
- XIF version 4.1 (e.g. FLON_V41.XIF)
- XIF version 4.4 (e.g. FLON_V44.XIF)

The device interface (XIF) file is a standalone file that documents the device interface for a type of device. It also documents the default values for all the configuration properties on the device. The different XIF files are for the different versions of the LonMaker[®] tool. The appropriate XIF file version is chosen depending on the installation tool used.

8

Network variables

What this chapter contains

This chapter describes the supported input and output, and network configuration properties.

Supported input network variables

The actual valid range of a network input variable can be smaller than the one reported in this manual, depending on the drive firmware. Typically the drive discards the parameter changes, if the value coming from the fieldbus is outside the range of the drive parameter. For the list of the network variables that are used with the drives compatible with the adapter module, see chapter [Appendix – Compatibility table](#) on page 123.

Name	Description	More info on page
nviAnlgCmd1 ... nviAnlgCmd8	Supply of analog commands to the host	44
nviCtlOverrideCm	Request for override of control and references sources by the network	45
nviDigCmd1 ... nviDigCmd12	Control of state of digital outputs 1 to 12	46
nviDrvProcStpt	Low-resolution process set point	46
nviDrvSpeedScale	Scaling for nviDrvSpeedStpt	47

Name	Description	More info on page
<i>nviDrvSpeedStpt</i>	Low-resolution speed set point	48
<i>nviEmrgOverride</i>	Possibility to stop the motor in case of an emergency	48
<i>nviExt1Ext2Ctrl</i>	Sets the control location that should be used (EXT1/EXT2)	49
<i>nviLocLock</i>	Sets local lock on or off	50
<i>nviRequest</i>	Enables control commands and updates from network	50
<i>nviResetFault</i>	Input to the motor to clear the fault status in the drive	51
<i>nviRunEnable</i>	Sets the run enable for the host	52
<i>nviSavePars</i>	Request for parameter save to non-volatile memory by network	52
<i>nviStartEnable1</i>	Sets start enable 1 for the host	53
<i>nviStartEnable2</i>	Sets start enable 2 for the host	53

■ **nviAnlgCmd1 ... nviAnlgCmd8**

Definition:

Network input SNVT_lev_percent nviAnlgCmd1
 Network input SNVT_lev_percent nviAnlgCmd2
 Network input SNVT_lev_percent nviAnlgCmd3
 Network input SNVT_lev_percent nviAnlgCmd4
 Network input SNVT_lev_percent nviAnlgCmd5
 Network input SNVT_lev_percent nviAnlgCmd6
 Network input SNVT_lev_percent nviAnlgCmd7
 Network input SNVT_lev_percent nviAnlgCmd8

Explanation:

Each variable supplies an analog command (1 ... 8) to the host. The configuration and mapping of these points is host-specific.

Valid range:

Value	Analog command
-32768	-163.84%
32766	163.83%
0x7FFF	Invalid

Default value:

The default value is 0%.

■ nviCtlOverrideCm

Definition:

Network input SNVT_switch nviCtlOverrideCm

Explanation:

This variable issues a request to override control and reference sources by the network.

Valid range:

State	Value	Override command
0	0%	No override
1	100%	Network overrides control and reference

Default value:

The default value is No override (state 0, value 0%). This value will be adopted at power-up and in case of not receiving an update within the specified Receive Heartbeat time.

■ nviDigCmd1 ... nviDigCmd12

Definition:

Network input SNVT_switch nviDigCmd1
 Network input SNVT_switch nviDigCmd2
 Network input SNVT_switch nviDigCmd3
 Network input SNVT_switch nviDigCmd4
 Network input SNVT_switch nviDigCmd5
 Network input SNVT_switch nviDigCmd6
 Network input SNVT_switch nviDigCmd7
 Network input SNVT_switch nviDigCmd8
 Network input SNVT_switch nviDigCmd9
 Network input SNVT_switch nviDigCmd10
 Network input SNVT_switch nviDigCmd11
 Network input SNVT_switch nviDigCmd12

Explanation:

Each variable supplies a digital command (1 ... 12) to the host. The configuration and mapping of these points is host-specific.

Valid range:

State	Value	Digital command
0	0%	Inactive
1	100%	Active

Default value:

The default value is Inactive (state 0, value 0%).

■ nviDrvProcStpt

Definition:

Network input SNVT_switch nviDrvProcStpt

Explanation:

This variable provides start/stop control and a low resolution process set point. It is active when external control location EXT2 is selected.

Valid range:

State	Value	Command
0	Not used	Stop
1	0	0%
1	1 to 200	0.5 to 100.0%
1	201 to 255	100%
0xFF	Not used	AUTO (Invalid)

Default value:

The default value is AUTO (state 0xFF). This value will be adopted at power-up and in case of not receiving an update within the specified Receive Heartbeat time.

■ **nviDrvSpeedScale**

Definition:

Network input SNVT_lev_percent nviDrvSpeedScale

Explanation:

This variable provides scaling for *nviDrvSpeedStpt*. For example, if the *nviDrvSpeedStpt* value is 100% and the *nviDrvSpeedScale* value is -150%, then the actual speed set point value is -150% meaning 1.5 times the nominal speed in the reverse direction.

Valid range:

Value	Speed scaling
-32768	-163.840%
32766	163.830%
0x7FFF	Invalid

Default value:

The value is defined by *SCPTdefScale / nciDrvSpeedScale*. This value will be adopted at power-up and in case of not receiving an update within the specified Receive Heartbeat time.

■ nviDrvSpeedStpt

Definition:

Network input SNVT_switch nviDrvSpeedStpt

Explanation:

This variable provides start/stop control and a low-resolution speed set point for external control location EXT1. The speed set point is the result of multiplication of *nviDrvSpeedStpt* and *nviDrvSpeedScale*. For example, if the value of *nviDrvSpeedStpt* is 100% and the value of *nviDrvSpeedScale* is -150%, the actual speed set point value is -150% meaning 1.5 times nominal speed in the reverse direction.

Valid range:

State	Value	Equivalent percentage	Requested speed
0	Not used	Not used	STOPPED
1	0	0%	0%
1	1 to 100	1 to 100.0%	1 to 100.0%
0xFF	Not used	Not used	AUTO (invalid)

Default value:

The default value is AUTO (state 0xFF). The value will be adapted at power-up and in case of not receiving an update within the specified Receive Heartbeat time.

■ nviEmrgOverride

Definition:

Network input SNVT_hvac_emerg nviEmrgOverride (HVAC Emergency Mode)

Explanation:

This variable provides the possibility to stop the motor in case of an emergency.

Valid range:

Setting	Function
EMERG_NORMAL	No emergency mode, motor control enabled.
EMERG_PRESSURIZE	See EMERG_NORMAL
EMERG_DEPRESSURIZE	See EMERG_NORMAL
EMERG_PURGE	See EMERG_NORMAL
EMERG_SHUTDOWN	Emergency shutdown mode. Stops motor.
EMERG_FIRE	See EMERG_NORMAL
EMERG_NULL	See EMERG_NORMAL

Default value:

The default value is EMERG_NORMAL. The value will be adapted at power-up and in case of not receiving an update within the specified Receive Heartbeat time.

■ nviExt1Ext2Ctrl

Definition:

Network input SNVT_switch nviExt1Ext2Ctrl

Explanation:

This variable sets the external control location (EXT1/EXT2).

Valid range:

State	Value	Control location
0	0%	EXT1
1	100%	EXT2

Default value:

The default value is EXT1 (state 0, value 0%).

■ nviLocLock

Definition:

Network input SNVT_switch nviLocLock

Explanation:

This variable sets local lock on or off.

Valid range:

State	Value	Command
0	0%	Local lock is off
1	100%	Local lock is on

Default value:

The default value is Local lock off (state 0, value 0%). This value will be adopted at power-up and in case of not receiving an update within the specified Receive Heartbeat time.

■ nviRequest

Definition:

Network input SNVT_obj_request nviRequest

Explanation:

This variable enables control commands and updates from the network. The status of the node is reported in nvoStatus.

Valid range:

Object request	Function
RQ_UPDATE_STATUS	Updates nvoStatus.
RQ_CLEAR_STATUS	Clears nvoStatus.
RQ_CLEAR_ALARM	Resets fault in the drive/bypass.
RQ_REPORT_MASK	Reports supported requests in nvoStatus.
RQ_NORMAL	Sets object to default state. (normal request)

Object request	Function
RQ_DISABLE	Stops the drive/bypass with the selected stop mode and disables the operation and object.
RQ_ENABLE	Enables the drive for operation and enables the object.

The commands not listed above will be reported as `invalid_request` in `nvoStatus`.

■ nviResetFault

Definition:

Network input SNVT_switch nviResetFault

Explanation:

This variable clears the fault status in the host.

Valid range:

State	Value	Command
0	0%	Enable reset fault
1	100%	Reset fault

On a transition from 0 to 1, this input network variable clears the fault condition in the drive. Following a fault reset, this variable should be set to 0 to enable the next reset fault.

Default value:

The default value is No action (state 0, value 0%). This value will be adopted at power-up and in case of not receiving an update within the specified Receive Heartbeat time.

■ nviRunEnable

Definition:

Network input SNVT_switch nviRunEnable

Explanation:

This variable sets the run enable for the host.

Valid range:

State	Value	Command
0	0%	Run disabled
1	100%	Run enabled

Default value:

The default value is Run disabled (state 0, value 0%). This value will be adopted at power-up and in case of not receiving an update within the specified Receive Heartbeat time.

■ nviSavePars

Definition:

Network input SNVT_switch nviSavePars

Explanation:

This variable indicates that the LONWORKS[®] network requests parameters to be saved to non-volatile memory.

Valid range:

State	Value	Command
0	0%	Do nothing
1	100%	Save parameters

Default value:

The default value is Do nothing (state 0, value 0%). This value will be adopted at power-up.

■ nviStartEnable1

Definition:

Network input SNVT_switch nviStartEnable1

Explanation:

This variable sets start enable 1 for the host.

Valid range:

State	Value	Command
0	0%	Start 1 disabled
1	100%	Start 1 enabled

Default value:

The default value is Start 1 disabled (state 0, value 0%). This value will be adopted at power-up and in case of not receiving an update within the specified Receive Heartbeat time.

■ nviStartEnable2

Definition:

Network input SNVT_switch nviStartEnable2

Explanation:

This variable sets start enable 2 for the host.

Valid range:

State	Value	Command
0	0%	Start 2 disabled
1	100%	Start 2 enabled

Default value:

The default value is Start 2 disabled (state 0, value 0%). This value will be adopted at power-up and in case of not receiving an update within the specified Receive Heartbeat time.

Supported output network variables

Name	Description	More info on page
<i>nvoAccelerating</i>	Indicates the drive is accelerating	56
<i>nvoAlarm</i>	Indicates the drive has an alarm	58
<i>nvoAnlgInput1 ... nvoAnlgInput8</i>	Status of analog inputs 1 to 8	58
<i>nvoAnlgOutput1 ... nvoAnlgOutput8</i>	Status of analog outputs 1 to 8	59
<i>nvoAnlgSts1 ... nvoAnlgSts8</i>	Analog statuses 1 to 8 from the host	60
<i>nvoAtReference</i>	Indicates the drive is at reference	61
<i>nvoBypKwh_R</i>	Value of the resettable bypass kWh counter *	61
<i>nvoBypRunHours</i>	Operation time for the motor by the bypass in whole hours *	62
<i>nvoBypTemp</i>	Bypass PCB temperature in degrees C *	63
<i>nvoCtlOverrideSt</i>	Indicates that the LonWorks® network has overridden other control and reference sources	64
<i>nvoDecelerating</i>	Indicates the drive is decelerating	64
<i>nvoDigInput1 ... nvoDigInput12</i>	Status of digital inputs 1 to 8	65
<i>nvoDigOutput1 ... nvoDigOutput12</i>	Status of digital outputs 1 to 8	66
<i>nvoDigSts1 ... nvoDigSts12</i>	Digital statuses 1 to 8 from the host	67
<i>nvoDrvCumt</i>	Drive current in amperes	68
<i>nvoDrvDCBus</i>	Drive DC bus voltage	69
<i>nvoDrvKwh_NR</i>	Value of the non-resettable drive kWh counter	70
<i>nvoDrvKwh_R</i>	Value of the resettable drive kWh counter	71
<i>nvoDrvPwr</i>	Drive power in kilowatts	72

Name	Description	More info on page
<i>nvoDrvRunHours</i>	Operation time for the motor by the drive in whole hours	72
<i>nvoDrvSpeed</i>	Speed of the drive as a percentage of the nominal speed	73
<i>nvoDrvTemp</i>	Temperature in degrees C	74
<i>nvoDrvTorque</i>	Output torque as a percentage of motor nominal torque	75
<i>nvoDrvVolt</i>	Motor output voltage	75
<i>nvoEmrgOvrStat</i>	Feedback for <i>nviEmrgOverride</i>	76
<i>nvoEnabled</i>	Indicates the drive has received the run enable command	77
<i>nvoExt1Ext2Stat</i>	Control location currently used (EXT1/EXT2)	77
<i>nvoFaultCode</i>	Latest malfunction code that has occurred	78
<i>nvoFaulted</i>	Information on the fault status of the drive	79
<i>nvoForward</i>	Indicates the drive is running in the forward direction	79
<i>nvoFreqAct</i>	Output frequency in Hz	80
<i>nvoLimit</i>	Indicates the drive has reached a speed, frequency or torque limit	81
<i>nvoLineUVVolt</i> , <i>nvoLineVWVolt</i> , <i>nvoLineWUVolt</i>	Line-to-line input voltages in volts	81
<i>nvoLineVolt</i>	Drive input voltage	82
<i>nvoLocRemStat</i>	Control mode (Local or Remote)	83
<i>nvoMtrRevCntM</i>	Accumulated revolutions of the motor in millions	84
<i>nvoMtrTemp</i>	Motor temperature in degrees C	85
<i>nvoNetCtrl</i>	Indicates the LonWorks® network is selected as the active control source	85

Name	Description	More info on page
<i>nvoNetRef1</i>	Indicates the LonWorks® network is selected as the active reference REF1 source	86
<i>nvoNetRef2</i>	Indicates the LonWorks® network is selected as the active reference REF2 source	87
<i>nvoParReadValue</i>	Data read at parameter set by <i>UCPTparReadIndex</i> / <i>nciParReadIndex</i>	87
<i>nvoPid1Dev</i> , <i>nvoPid2Dev</i>	PID controller deviation values	88
<i>nvoPid1Fbk</i> , <i>nvoPid2Fbk</i>	PID controller feedback values	89
<i>nvoReady</i>	Indicates the drive is ready to receive a start command	89
<i>nvoReverse</i>	Indicates the drive is running in the reverse direction	90
<i>nvoRunning</i>	Motor running state	91
<i>nvoSpeedActRpm</i>	Output speed in rpm	91
<i>nvoStarted</i>	Indicates the drive has received a start command	92
<i>nvoStatus</i>	Reports the node object status	93
<i>nvoZeroSpeed</i>	Indicates the drive is at zero speed	93

* not for generic drive use

nvoAccelerating

Definition:

Network output SNVT_switch nvoAccelerating

Explanation:

This variable indicates that the drive is accelerating.

Valid range:

State	Value	Status
0	0.0%	Not accelerating
1	100.0%	Accelerating

When transmitted:

This value is transmitted immediately when its value has changed significantly. Additionally, this network variable will also be transmitted as a heartbeat output on a regular basis as specified by the Maximum Sent Time (`nciVsmdSndHrtBt`) configuration value.

Update rate:

This value will be updated no faster than the Minimum Send Time (`nciVsmdMinOutTm`) configuration value, if used.

■ nvoAlarm

Definition:

Network output SNVT_switch nvoAlarm

Explanation:

This variable indicates that the drive has an alarm.

Valid range:

State	Value	Status
0	0.0%	No alarm
1	100.0%	Alarm

When transmitted:

This value is transmitted immediately when its value has changed significantly. Additionally, this network variable will also be transmitted as a heartbeat output on a regular basis as specified by the Maximum Sent Time (nciVsmoSndHrtBt) configuration value.

Update rate:

This value will be updated no faster than the Minimum Send Time (nciVsmoMinOutTm) configuration value, if used.

■ nvoAnIInput1 ... nvoAnIInput8

Definition:

Network output SNVT_lev_percent nvoAnIInput1
 Network output SNVT_lev_percent nvoAnIInput2
 Network output SNVT_lev_percent nvoAnIInput3
 Network output SNVT_lev_percent nvoAnIInput4
 Network output SNVT_lev_percent nvoAnIInput5
 Network output SNVT_lev_percent nvoAnIInput6
 Network output SNVT_lev_percent nvoAnIInput7
 Network output SNVT_lev_percent nvoAnIInput8

Explanation:

Each variable indicates the value of the corresponding analog input (1 ... 8) of the host.

Valid range:

Value	Analog input value
-32768	-163.84%
32766	163.83%
0x7FFF	Invalid

When transmitted:

This value is transmitted immediately when its value has changed significantly. Additionally, this network variable will also be transmitted as a heartbeat output on a regular basis as specified by the Maximum Sent Time (`nciVsmdSndHrtBt`) configuration value.

Update rate:

This value will be updated no faster than the Minimum Send Time (`nciVsmdMinOutTm`) configuration value, if used.

■ **nvoAnlgOutput1 ... nvoAnlgOutput8**

Definition:

Network output SNVT_lev_percent nvoAnlgOutput1
 Network output SNVT_lev_percent nvoAnlgOutput2
 Network output SNVT_lev_percent nvoAnlgOutput3
 Network output SNVT_lev_percent nvoAnlgOutput4
 Network output SNVT_lev_percent nvoAnlgOutput5
 Network output SNVT_lev_percent nvoAnlgOutput6
 Network output SNVT_lev_percent nvoAnlgOutput7
 Network output SNVT_lev_percent nvoAnlgOutput8

Explanation:

Each variable indicates the value of the corresponding analog output (1 ... 8) of the host.

Valid range:

Value	Analog output value
-32768	-163.84%
32766	163.83%
0x7FFF	Invalid

When transmitted:

This value is transmitted immediately when its value has changed significantly. Additionally, this network variable will also be transmitted as a heartbeat output on a regular basis as specified by the Maximum Sent Time (`nciVsmoSndHrtBt`) configuration value.

Update rate:

This value will be updated no faster than the Minimum Send Time (`nciVsmOMinOutTm`) configuration value, if used.

■ `nvoAnlgSts1 ... nvoAnlgSts8`

Definition:

Network output `SNVT_lev_percent nvoAnlgSts1`

Network output `SNVT_lev_percent nvoAnlgSts2`

Network output `SNVT_lev_percent nvoAnlgSts3`

Network output `SNVT_lev_percent nvoAnlgSts4`

Network output `SNVT_lev_percent nvoAnlgSts5`

Network output `SNVT_lev_percent nvoAnlgSts6`

Network output `SNVT_lev_percent nvoAnlgSts7`

Network output `SNVT_lev_percent nvoAnlgSts8`

Explanation:

Each variable indicates an analog status (1 ... 8) from the host. The configuration and mapping of these points is host-specific.

Valid range:

Value	Analog status
-32768	-163.84%
32766	163.83%
0x7FFF	Invalid

When transmitted:

This value is transmitted immediately when its value has changed significantly. Additionally, this network variable will also be transmitted as a heartbeat output on a regular basis as specified by the Maximum Sent Time (`nciVsmoSndHrtBt`) configuration value.

Update rate:

This value will be updated no faster than the Minimum Send Time (nciVsmdMinOutTm) configuration value, if used.

■ nvoAtReference

Definition:

Network output SNVT_switch nvoAtReference

Explanation:

This variable indicates that the drive is at reference.

Valid range:

State	Value	Status
0	0.0%	Not at reference
1	100.0%	At reference

When transmitted:

This value is transmitted immediately when its value has changed significantly. Additionally, this network variable will also be transmitted as a heartbeat output on a regular basis as specified by the Maximum Sent Time (nciVsmdSndHrtBt) configuration value.

Update rate:

This value will be updated no faster than the Minimum Send Time (nciVsmdMinOutTm) configuration value, if used.

■ nvoBypKwh_R

Definition:

Network output SNVT_elec_kwh_I nvoBypKwh_R

Explanation:

This variable provides the value of the resettable bypass kWh counter.

Valid range:

Value	Energy
-2147483648	-214748364.8 kWh
2147483646	214748364.6 kWh
0x7FFFFFFF	Invalid

When transmitted:

This value is transmitted immediately when its value has changed significantly. Additionally, this network variable will also be transmitted as a heartbeat output on a regular basis as specified by the Maximum Sent Time (nciVsmdSndHrtBt) configuration value.

Update rate:

This value will be updated no faster than the Minimum Send Time (nciVsmdMinOutTm) configuration value, if used.

Note: This variable is not meant for generic drive use.

nvoBypRunHours

Definition:

Network output SNVT_time_hour nvoBypRunHours

Explanation:

This variable provides the total operation time for the motor by the bypass in running hours.

Valid range:

Value	Time
0	0.0 h
65534	65534 h
65535	Invalid

When transmitted:

This value is transmitted immediately when its value has changed significantly. Additionally, this network variable will also be transmitted as a heartbeat output on a regular basis as specified by the Maximum Sent Time (nciVsmdSndHrtBt) configuration value.

Update rate:

This value will be updated no faster than the Minimum Send Time (nciVsmdMinOutTm) configuration value, if used.

Note: This variable is not meant for generic drive use.

■ nvoBypTemp

Definition:

Network output SNVT_temp_p nvoBypTemp

Explanation:

This variable provides the bypass PCB temperature in degrees C.

Valid range:

Value	Temperature
-27317	-273.17 °C
0	0 °C
32767	327.67 °C

When transmitted:

This value is transmitted immediately when its value has changed significantly. Additionally, this network variable will also be transmitted as a heartbeat output on a regular basis as specified by the Maximum Sent Time (nciVsmdSndHrtBt) configuration value.

Update rate:

This value will be updated no faster than the Minimum Send Time (nciVsmdMinOutTm) configuration value, if used.

Note: This variable is not meant for generic drive use.

■ nvoCtlOverrideSt

Definition:

Network output SNVT_switch nvoCtlOverrideSt

Explanation:

This variable indicates that the LONWORKS[®] network has overridden other control and reference sources.

Valid range:

State	Value	Control source
0	0.0	Other
1	100.0	Network

When transmitted:

This value is transmitted immediately when its value has changed significantly. Additionally, this network variable will also be transmitted as a heartbeat output on a regular basis as specified by the Maximum Sent Time (nciVsmdSndHrtBt) configuration value.

Update rate:

This value will be updated no faster than the Minimum Send Time (nciVsmdMinOutTm) configuration value, if used.

■ nvoDecelerating

Definition:

Network output SNVT_switch nvoDecelerating

Explanation:

This variable indicates that the drive is decelerating.

Valid range:

State	Value	Status
0	0.0%	Not decelerating
1	100.0%	Decelerating

When transmitted:

This value is transmitted immediately when its value has changed significantly. Additionally, this network variable will also be transmitted as a heartbeat output on a regular basis as specified by the Maximum Sent Time (`nciVsmdSndHrtBt`) configuration value.

Update rate:

This value will be updated no faster than the Minimum Send Time (`nciVsmdMinOutTm`) configuration value, if used.

■ **nvoDigInput1 ... nvoDigInput12**

Definition:

Network output SNVT_switch nvoDigInput1
 Network output SNVT_switch nvoDigInput2
 Network output SNVT_switch nvoDigInput3
 Network output SNVT_switch nvoDigInput4
 Network output SNVT_switch nvoDigInput5
 Network output SNVT_switch nvoDigInput6
 Network output SNVT_switch nvoDigInput7
 Network output SNVT_switch nvoDigInput8
 Network output SNVT_switch nvoDigInput9
 Network output SNVT_switch nvoDigInput10
 Network output SNVT_switch nvoDigInput11
 Network output SNVT_switch nvoDigInput12

Explanation:

Each variable indicates the status of the corresponding digital input (1 ... 12) of the host.

Valid range:

State	Value	Digital input status
0	0%	Inactive
1	100%	Active

When transmitted:

This value is transmitted immediately when its value has changed significantly. Additionally, this network variable will also be transmitted as a heartbeat output on a regular basis as specified by the Maximum Sent Time (nciVsmoSndHrtBt) configuration value.

Update rate:

This value will be updated no faster than the Minimum Send Time (nciVsmOMinOutTm) configuration value, if used.

■ nvoDigOutput1 ... nvoDigOutput12

Definition:

Network output SNVT_switch nvoDigOutput1
 Network output SNVT_switch nvoDigOutput2
 Network output SNVT_switch nvoDigOutput3
 Network output SNVT_switch nvoDigOutput4
 Network output SNVT_switch nvoDigOutput5
 Network output SNVT_switch nvoDigOutput6
 Network output SNVT_switch nvoDigOutput7
 Network output SNVT_switch nvoDigOutput8
 Network output SNVT_switch nvoDigOutput9
 Network output SNVT_switch nvoDigOutput10
 Network output SNVT_switch nvoDigOutput11
 Network output SNVT_switch nvoDigOutput12

Explanation:

Each variable indicates the status of the corresponding digital output (1 ... 12) of the host.

Valid range:

State	Value	Digital output status
0	0%	Inactive
1	100%	Active

When transmitted:

This value is transmitted immediately when its value has changed significantly. Additionally, this network variable will also be transmitted as a heartbeat output on a regular basis as specified by the Maximum Sent Time (`nciVsmdSndHrtBt`) configuration value.

Update rate:

This value will be updated no faster than the Minimum Send Time (`nciVsmdMinOutTm`) configuration value, if used.

■ **nvoDigSts1 ... nvoDigSts12**

Definition:

Network output SNVT_switch nvoDigSts1
 Network output SNVT_switch nvoDigSts2
 Network output SNVT_switch nvoDigSts3
 Network output SNVT_switch nvoDigSts4
 Network output SNVT_switch nvoDigSts5
 Network output SNVT_switch nvoDigSts6
 Network output SNVT_switch nvoDigSts7
 Network output SNVT_switch nvoDigSts8
 Network output SNVT_switch nvoDigSts9
 Network output SNVT_switch nvoDigSts10
 Network output SNVT_switch nvoDigSts11
 Network output SNVT_switch nvoDigSts12

Explanation:

Each variable indicates a digital status (1 ... 12) from the host. The configuration and mapping of these points is host-specific.

Valid range:

State	Value	Digital status
0	0%	Inactive
1	100%	Active

When transmitted:

This value is transmitted immediately when its value has changed significantly. Additionally, this network variable will also be transmitted as a heartbeat output on a regular basis as specified by the Maximum Sent Time (nciVsmdSndHrtBt) configuration value.

Update rate:

This value will be updated no faster than the Minimum Send Time (nciVsmdMinOutTm) configuration value, if used.

■ nvoDrvCurnt

Definition:

Network output SNVT_amp nvoDrvCurnt

Explanation:

This variable provides the drive current in amperes.

Valid Range:

Value	Current
0	0.0 A
32766	3276.6 A
0x7FFF	Invalid

When transmitted:

This value is transmitted immediately when its value has changed significantly. Additionally, this network variable will also be transmitted as a heartbeat output on a regular basis as specified by the Maximum Sent Time (nciVsmdSndHrtBt) configuration value.

Update rate:

This value will be updated no faster than the Minimum Send Time (nciVsmdMinOutTm) configuration value, if used.

■ nvoDrvDCBus

Definition:

Network output SNVT_volt nvoDrvDCBus

Explanation:

This variable provides the drive DC bus voltage.

Valid range:

Value	Voltage
0	0.0 V
3276.6	3276.6 V
0x7FFF	Invalid

When transmitted:

This value is transmitted immediately when its value has changed significantly. Additionally, this network variable will also be transmitted as a heartbeat output on a regular basis as specified by the Maximum Sent Time (nciVsmdSndHrtBt) configuration value.

Update rate:

This value will be updated no faster than the Minimum Send Time (nciVsmdMinOutTm) configuration value, if used.

■ nvoDrvKwh_NR

Definition:

Network output SNVT_elec_kwh_I nvoDrvKwh_NR

Explanation:

This variable provides the value of the non-resettable drive kWh counter.

Valid range:

Value	Energy
-2147483648	-214748364.8 kWh
2147483646	214748364.6 kWh
0x7FFFFFFF	Invalid

When transmitted:

This value is transmitted immediately when its value has changed significantly. Additionally, this network variable will also be transmitted as a heartbeat output on a regular basis as specified by the Maximum Sent Time (nciVsmdSndHrtBt) configuration value.

Update rate:

This value will be updated no faster than the Minimum Send Time (nciVsmdMinOutTm) configuration value, if used.

■ nvoDrvKwh_R

Definition:

Network output SNVT_elec_kwh_I nvoDrvKwh_R

Explanation:

This variable provides the value of the resettable drive kWh counter.

Valid range:

Value	Energy
-2147483648	-214748364.8 kWh
2147483646	214748364.6 kWh
0x7FFFFFFF	Invalid

When transmitted:

This value is transmitted immediately when its value has changed significantly. Additionally, this network variable will also be transmitted as a heartbeat output on a regular basis as specified by the Maximum Sent Time (nciVsmdSndHrtBt) configuration value.

Update rate:

This value will be updated no faster than the Minimum Send Time (nciVsmdMinOutTm) configuration value, if used.

■ nvoDrvPwr

Definition:

Network output SNVT_power_kilo nvoDrvPwr

Explanation:

This variable provides drive power in kilowatts.

Valid range:

Value	Power
0	0.0 kW
65534	6553.4 kW
65535	Invalid

When transmitted:

This value is transmitted immediately when its value has changed significantly. Additionally, this network variable will also be transmitted as a heartbeat output on a regular basis as specified by the Maximum Sent Time (nciVsmdSndHrtBt) configuration value.

Update rate:

This value will be updated no faster than the Minimum Send Time (nciVsmdMinOutTm) configuration value, if used.

■ nvoDrvRunHours

Definition:

Network output SNVT_time_hour nvoDrvRunHours

Explanation:

This variable provides the total operation time for the motor by the drive in running hours.

Valid range:

Value	Time
0	0.0 h
65534	65534 h
65535	Invalid

When transmitted:

This value is transmitted immediately when its value has changed significantly. Additionally, this network variable will also be transmitted as a heartbeat output on a regular basis as specified by the Maximum Sent Time (nciVsmdSndHrtBt) configuration value.

Update rate:

This value will be updated no faster than the Minimum Send Time (nciVsmdMinOutTm) configuration value, if used.

■ nvoDrvSpeed

Definition:

Network output SNVT_lev_percent nvoDrvSpeed

Explanation:

This variable provides the speed of the drive as a percentage of the nominal speed.

Valid range:

Value	Speed
-32768	-163.84%
32766	163.83%
0x7FFF	Invalid

When transmitted:

This value is transmitted immediately when its value has changed significantly. Additionally, this network variable will also be transmitted as a heartbeat output on a regular basis as specified by the Maximum Sent Time (nciVsmdSndHrtBt) configuration value.

Update rate:

This value will be updated no faster than the Minimum Send Time (nciVsmdMinOutTm) configuration value, if used.

■ nvoDrvTemp

Definition:

Network output SNVT_temp_p nvoDrvTemp

Explanation:

This variable provides the drive temperature in degrees C.

Valid range:

Value	Temperature
-27317	-273.17 °C
0	0 °C
32767	327.67 °C

When transmitted:

This value is transmitted immediately when its value has changed significantly. Additionally, this network variable will also be transmitted as a heartbeat output on a regular basis as specified by the Maximum Sent Time (nciVsmdSndHrtBt) configuration value.

Update rate:

This value will be updated no faster than the Minimum Send Time (nciVsmdMinOutTm) configuration value, if used.

■ nvoDrvTorque

Definition:

Network output SNVT_lev_percent nvoDrvTorque

Explanation:

This variable provides output torque as a percentage of motor nominal torque.

Valid range:

Value	Torque
-32768	-163.84%
32766	163.83%
0x7FFF	Invalid

When transmitted:

This value is transmitted immediately when its value has changed significantly. Additionally, this network variable will also be transmitted as a heartbeat output on a regular basis as specified by the Maximum Sent Time (nciVsmdSndHrtBt) configuration value.

Update rate:

This value will be updated no faster than the Minimum Send Time (nciVsmdMinOutTm) configuration value, if used.

■ nvoDrvVolt

Definition:

Network output SNVT_volt nvoDrvVolt

Explanation:

This variable provides the motor output voltage.

Valid range:

Value	Voltage
0	0.0 V
3276.6	3276.6 V
0x7FFF	Invalid

When transmitted:

This value is transmitted immediately when its value has changed significantly. Additionally, this network variable will also be transmitted as a heartbeat output on a regular basis as specified by the Maximum Sent Time (nciVsmdSndHrtBt) configuration value.

Update rate:

This value will be updated no faster than the Minimum Send Time (nciVsmdMinOutTm) configuration value, if used.

■ nvoEmrgOvrStat

Definition:

Network output SNVT_hvac_emerg nvoEmrgOvrStat

Explanation:

This variable provides feedback for the nviEmrgOverride.

Valid range:

Value	Function
EMERG_NORMAL	No emergency mode, motor control enabled
EMERG_SHUTDOWN	Emergency shutdown mode. Stops motor.
EMERG_NUL	Invalid

When transmitted:

This value is transmitted immediately when its value has changed significantly. Additionally, this network variable will also be transmitted as a heartbeat output on a regular basis as specified by the Maximum Sent Time (nciVsmdSndHrtBt) configuration value.

Update rate:

This value will be updated no faster than the Minimum Send Time (nciVsmdMinOutTm) configuration value, if used.

■ **nvoEnabled**
Definition:

Network output SNVT_switch nvoEnabled

Explanation:

This variable indicates that the drive has received the run enable command.

Valid range:

State	Value	Status
0	0.0%	Not enabled
1	100.0%	Enabled

When transmitted:

This value is transmitted immediately when its value has changed significantly. Additionally, this network variable will also be transmitted as a heartbeat output on a regular basis as specified by the Maximum Sent Time (nciVsmdSndHrtBt) configuration value.

Update rate:

This value will be updated no faster than the Minimum Send Time (nciVsmdMinOutTm) configuration value, if used.

■ **nvoExt1Ext2Stat**
Definition:

Network output SNVT_switch nvoExt1Ext2Stat

Explanation:

This output variable shows the external control location currently used (EXT1 or EXT2).

Valid range:

State	Value	Control location
0	0%	EXT1
1	100%	EXT2

When transmitted:

This value is transmitted immediately when its value has changed significantly. Additionally, this network variable will also be transmitted as a heartbeat output on a regular basis as specified by the Maximum Sent Time (nciVsmdSndHrtBt) configuration value.

Update rate:

This value will be updated no faster than the Minimum Send Time (nciVsmdMinOutTm) configuration value, if used.

■ nvoFaultCode**Definition:**

Network output SNVT_switch nvoFaultCode

Explanation:

This variable provides the current fault (DRIVECOMM) reported by host.

Valid range:

Value	Fault code
0 ... 65535	DRIVECOMM fault code

When transmitted:

This value is transmitted immediately when its value has changed significantly. Additionally, this network variable will also be transmitted as a heartbeat output on a regular basis as specified by the Maximum Sent Time (nciVsmdSndHrtBt) configuration value.

Update rate:

This value will be updated no faster than the Minimum Send Time (nciVsmdMinOutTm) configuration value, if used.

■ nvoFaulted

Definition:

Network output SNVT_switch nvoFaulted

Explanation:

This variable provides information on the fault status of the host.

Valid range:

State	Value	Status
0	0.0	Not faulted
1	100.0	Faulted

When transmitted:

This value is transmitted immediately when its value has changed significantly. Additionally, this network variable will also be transmitted as a heartbeat output on a regular basis as specified by the Maximum Sent Time (nciVsmdSndHrtBt) configuration value.

Update rate:

This value will be updated no faster than the Minimum Send Time (nciVsmdMinOutTm) configuration value, if used.

■ nvoForward

Definition:

Network output SNVT_switch nvoForward

Explanation:

This variable indicates that the drive is running in the forward direction.

Valid range:

State	Value	Status
0	0.0%	Not forward
1	100.0%	Forward

When transmitted:

This value is transmitted immediately when its value has changed significantly. Additionally, this network variable will also be transmitted as a heartbeat output on a regular basis as specified by the Maximum Sent Time (nciVsmdSndHrtBt) configuration value.

Update rate:

This value will be updated no faster than the Minimum Send Time (nciVsmdMinOutTm) configuration value, if used.

■ **nvoFreqAct**
Definition:

Network output SNVT_freq_hz nvoFreqAct

Explanation:

This variable shows output frequency in Hz.

Valid range:

Value	Frequency
0	0.0 Hz
65535	6553.5 Hz

When transmitted:

This value is transmitted immediately when its value has changed significantly. Additionally, this network variable will also be transmitted as a heartbeat output on a regular basis as specified by the Maximum Sent Time (nciVsmdSndHrtBt) configuration value.

Update rate:

This value will be updated no faster than the Minimum Send Time (nciVsmdMinOutTm) configuration value, if used.

nvoLimit**Definition:**

Network output SNVT_switch nvoLimit

Explanation:

This variable indicates that the drive has reached a speed, frequency or torque limit.

Valid range:

State	Value	Status
0	0.0%	Within limits
1	100.0%	Out of limits

When transmitted:

This value is transmitted immediately when its value has changed significantly. Additionally, this network variable will also be transmitted as a heartbeat output on a regular basis as specified by the Maximum Sent Time (nciVsmdSndHrtBt) configuration value.

Update rate:

This value will be updated no faster than the Minimum Send Time (nciVsmdMinOutTm) configuration value, if used.

nvoLineUVolt, nvoLineVWVult, nvoLineWUVolt**Definition:**

Network output SNVT_volt nvoLineUVolt
 Network output SNVT_volt nvoLineVWVult
 Network output SNVT_volt nvoLineWUVolt

Explanation:

Each variable provides the corresponding line-to-line input voltage in volts.

Valid range:

Value	Voltage
0	0.0 V
3276.6	3276.6 V
0x7FFF	Invalid

When transmitted:

This value is transmitted immediately when its value has changed significantly. Additionally, this network variable will also be transmitted as a heartbeat output on a regular basis as specified by the Maximum Sent Time (nciVsmdSndHrtBt) configuration value.

Update rate:

This value will be updated no faster than the Minimum Send Time (nciVsmdMinOutTm) configuration value, if used.

■ **nvoLineVolt**
Definition:

Network output SNVT_volt nvoLineVolt

Explanation:

This variable provides the drive input voltage in volts.

Valid range:

Value	Voltage
0	0.0 V
3276.6	3276.6 V
0x7FFF	Invalid

When transmitted:

This value is transmitted immediately when its value has changed significantly. Additionally, this network variable will also be transmitted as a heartbeat output on a regular basis as specified by the Maximum Sent Time (nciVsmdSndHrtBt) configuration value.

Update rate:

This value will be updated no faster than the Minimum Send Time (nciVsmdMinOutTm) configuration value, if used.

■ nvoLocRemStat

Definition:

Network output SNVT_switch nvoLocRemStat

Explanation:

This output variable shows if the drive is in the Local or Remote control mode.

Valid range:

State	Value	Control mode
0	0%	Local
1	100%	Remote

When transmitted:

This value is transmitted immediately when its value has changed significantly. Additionally, this network variable will also be transmitted as a heartbeat output on a regular basis as specified by the Maximum Sent Time (nciVsmdSndHrtBt) configuration value.

Update rate:

This value will be updated no faster than the Minimum Send Time (nciVsmdMinOutTm) configuration value, if used.

■ nvoMtrRevCntM

Definition:

Network output SNVT_count_32 nvoMtrRevCntM

Explanation:

This variable shows accumulated revolutions of the motor in millions.

Valid range:

Value	Motor revolutions
0	0
1	1,000,000
4294967295	4,294,967,295,000,000

When transmitted:

This value is transmitted immediately when its value has changed significantly. Additionally, this network variable will also be transmitted as a heartbeat output on a regular basis as specified by the Maximum Sent Time (nciVsmdSndHrtBt) configuration value.

Update rate:

This value will be updated no faster than the Minimum Send Time (nciVsmdMinOutTm) configuration value, if used.

■ nvoMtrTemp

Definition:

Network output SNVT_temp_p nvoMtrTemp

Explanation:

This variable provides the motor temperature in degrees C.

Valid range:

Value	Temperature
-27317	-273.17 °C
0	0 °C
32767	327.67 °C

When transmitted:

This value is transmitted immediately when its value has changed significantly. Additionally, this network variable will also be transmitted as a heartbeat output on a regular basis as specified by the Maximum Sent Time (nciVsmdSndHrtBt) configuration value.

Update rate:

This value will be updated no faster than the Minimum Send Time (nciVsmdMinOutTm) configuration value, if used.

■ nvoNetCtrl

Definition:

Network output SNVT_switch nvoNetCtrl

Explanation:

This variable indicates that the LONWORKS[®] network is selected as the active control source.

Valid range:

State	Value	Control source
0	0.0%	Other
1	100.0%	Network

When transmitted:

This value is transmitted immediately when its value has changed significantly. Additionally, this network variable will also be transmitted as a heartbeat output on a regular basis as specified by the Maximum Sent Time (nciVsmdSndHrtBt) configuration value.

Update rate:

This value will be updated no faster than the Minimum Send Time (nciVsmdMinOutTm) configuration value, if used.

■ **nvoNetRef1**
Definition:

Network output SNVT_switch nvoNetRef1

Explanation:

This variable indicates that the LONWORKS[®] network is selected as the active reference REF1 source.

Valid range:

State	Value	Reference Source
0	0.0%	Other
1	100.0%	Network

When transmitted:

This value is transmitted immediately when its value has changed significantly. Additionally, this network variable will also be transmitted as a heartbeat output on a regular basis as specified by the Maximum Sent Time (nciVsmdSndHrtBt) configuration value.

Update rate:

This value will be updated no faster than the Minimum Send Time (nciVsmdMinOutTm) configuration value, if used.

■ nvoNetRef2

Definition:

Network output SNVT_switch nvoNetRef2

Explanation:

This variable indicates that the LONWORKS[®] network is selected as the active reference REF2 source.

Valid range:

State	Value	Reference Source
0	0.0%	Other
1	100.0%	Network

When transmitted:

This value is transmitted immediately when its value has changed significantly. Additionally, this network variable will also be transmitted as a heartbeat output on a regular basis as specified by the Maximum Sent Time (nciVsmdSndHrtBt) configuration value.

Update rate:

This value will be updated no faster than the Minimum Send Time (nciVsmdMinOutTm) configuration value, if used.

■ nvoParReadValue

Definition:

Network output SNVT_count nvoParReadValue

Explanation:

This variable contains the value read from the parameter set by [UCPTparReadIndex / nciParReadIndex](#).

Valid range:

Value	Parameter value
0 ... 65534	Parameter-dependent
0xFFFF	Invalid

When transmitted:

This value is transmitted immediately when its value has changed significantly. Additionally, this network variable will also be transmitted as a heartbeat output on a regular basis as specified by the Maximum Sent Time (nciVsmdSndHrtBt) configuration value.

Update rate:

This value will be updated no faster than the Minimum Send Time (nciVsmdMinOutTm) configuration value, if used.

■ **nvoPid1Dev, nvoPid2Dev**
Definition:

Network output SNVT_lev_percent nvoPID1Dev
 Network output SNVT_lev_percent nvoPID2Dev

Explanation:

This variable shows the PID controller deviation values.

Valid range:

Value	Feedback
-32768	-163.84%
32766	163.83%
32767	Invalid

When transmitted:

This value is transmitted immediately when its value has changed significantly. Additionally, this network variable will also be transmitted as a heartbeat output on a regular basis as specified by the Maximum Sent Time (nciVsmdSndHrtBt) configuration value.

Update rate:

This value will be updated no faster than the Minimum Send Time (nciVsmdMinOutTm) configuration value, if used.

■ nvoPid1Fbk, nvoPid2Fbk

Definition:

Network output SNVT_lev_percent nvoPid1Fbk
 Network output SNVT_lev_percent nvoPid2Fbk

Explanation:

This variable shows the PID controller feedback values.

Valid range:

Value	Feedback
-32768	-163.84%
32766	163.83%
32767	Invalid

When transmitted:

This value is transmitted immediately when its value has changed significantly. Additionally, this network variable will also be transmitted as a heartbeat output on a regular basis as specified by the Maximum Sent Time (nciVsmdSndHrtBt) configuration value.

Update rate:

This value will be updated no faster than the Minimum Send Time (nciVsmdMinOutTm) configuration value, if used.

■ nvoReady

Definition:

Network output SNVT_switch nvoReady

Explanation:

This variable indicates that the drive is ready to receive a start command.

Valid range:

State	Value	Status
0	0.0%	Not ready
1	100.0%	Ready

When transmitted:

This value is transmitted immediately when its value has changed significantly. Additionally, this network variable will also be transmitted as a heartbeat output on a regular basis as specified by the Maximum Sent Time (nciVsmdSndHrtBt) configuration value.

Update rate:

This value will be updated no faster than the Minimum Send Time (nciVsmdMinOutTm) configuration value, if used.

nvoReverse

Definition:

Network output SNVT_switch nvoReverse

Explanation:

This variable indicates that the drive is running in the reverse direction.

Valid range:

State	Value	Status
0	0.0%	Not reverse
1	100.0%	Reverse

When transmitted:

This value is transmitted immediately when its value has changed significantly. Additionally, this network variable will also be transmitted as a heartbeat output on a regular basis as specified by the Maximum Sent Time (nciVsmdSndHrtBt) configuration value.

Update rate:

This value will be updated no faster than the Minimum Send Time (nciVsmdMinOutTm) configuration value, if used.

■ nvoRunning

Definition:

Network output SNVT_switch nvoRunning

Explanation:

This variable indicates the motor running state.

Valid range:

State	Value	Status
0	0.0%	Not running
1	100.0%	Running

When transmitted:

This value is transmitted immediately when its value has changed significantly. Additionally, this network variable will also be transmitted as a heartbeat output on a regular basis as specified by the Maximum Sent Time (nciVsmdSndHrtBt) configuration value.

Update rate:

This value will be updated no faster than the Minimum Send Time (nciVsmdMinOutTm) configuration value, if used.

■ nvoSpeedActRpm

Definition:

Network output SNVT_count_inc nvoSpeedActRpm

Explanation:

This variable shows output speed in rpm.

Valid range:

Value	Speed
-32768	-32767 rpm
32767	32767 rpm

When transmitted:

This value is transmitted immediately when its value has changed significantly. Additionally, this network variable will also be transmitted as a heartbeat output on a regular basis as specified by the Maximum Sent Time (`nciVsmdSndHrtBt`) configuration value.

Update rate:

This value will be updated no faster than the Minimum Send Time (`nciVsmdMinOutTm`) configuration value, if used.

■ **nvoStarted**
Definition:

Network output `SNVT_switch nvoStarted`

Explanation:

This variable indicates that the drive has received a start command.

Valid range:

State	Value	Status
0	0.0%	Not started
1	100.0%	Started

When transmitted:

This value is transmitted immediately when its value has changed significantly. Additionally, this network variable will also be transmitted as a heartbeat output on a regular basis as specified by the Maximum Sent Time (`nciVsmdSndHrtBt`) configuration value.

Update rate:

This value will be updated no faster than the Minimum Send Time (nciVsmdMinOutTm) configuration value, if used.

■ nvoStatus

Definition:

Network output SNVT_obj_status nvoStatus

Explanation:

This variable reports the node object status.

Valid range:

Bit settings	Description/Function
invalid_id	Invalid node ID requested
report_mask	Reporting supported fields
disabled	RQ_DISABLE active
electrical_fault	Fault bit in Status word
in_alarm	Alarm bit in Status word

■ nvoZeroSpeed

Definition:

Network output SNVT_switch nvoZeroSpeed

Explanation:

This variable indicates that the drive is at zero speed.

Valid range:

State	Value	Status
0	0.0%	Not at zero speed
1	100.0%	At zero speed

When transmitted:

This value is transmitted immediately when its value has changed significantly. Additionally, this network variable will also be transmitted as a heartbeat output on a regular basis as specified by the Maximum Sent Time (`nciVsmdSndHrtBt`) configuration value.

Update rate:

This value will be updated no faster than the Minimum Send Time (`nciVsmdMinOutTm`) configuration value, if used.

Supported network configuration properties

All configuration properties are defined as configuration network variables in this product. Some network management tools will show these variables as SCPT/UCPT configuration properties and some as network configuration variables. The difference in the network management tools only affects the presentation of the variables but not their functionality.

Name	Description	More info on page
SCPTdefScale / nciDrvSpeedScale	Default value for nviDrvSpeedScale	98
SCPTlocation / nciLocation	Location label	98
SCPTmaxRcvTime / nciAnlgRcvHrtBt	Defines the maximum time after the last update of nviAnlgCmd1 ... nviAnlgCmd8 .	99
SCPTmaxRcvTime / nciDigRcvHrtBt	Defines the maximum time after the last update of nviDigCmd1 ... nviDigCmd12 .	99
SCPTmaxRcvTime / nciVsmRcvHrtBt	Defines the maximum allowed update interval for input network variables nviDrvSpeedStpt and nviDrvSpeedScale	100
SCPTmaxSendTime / nciAnlgSndHrtBt	Maximum time that expires before network variables nvoAnlgSts1 ... nvoAnlgSts8 , nvoAnlgInput1 ... nvoAnlgInput8 , nvoAnlgOutput1 ... nvoAnlgOutput8 will automatically be updated.	100
SCPTmaxSendTime / nciDigSndHrtBt	Maximum time that expires before network variables nvoDigSts1 ... nvoDigSts12 , nvoDigInput1 ... nvoDigInput12 , nvoDigOutput1 ... nvoDigOutput12 will automatically be updated.	101
SCPTmaxSendTime / nciVsmSndHrtBt	Maximum send time for the variable nvoDrvSpeed	102

Name	Description	More info on page
SCPTmaxSetpoint / nciMaxSpeed	Defines the maximum motor speed	102
SCPTminSendTime / nciAnlgMinOutTm	Defines the minimum wait time before network output variables nvoAnlgSts1 ... nvoAnlgSts8 , nvoAnlgInput1 ... nvoAnlgInput8 , nvoAnlgOutput1 ... nvoAnlgOutput8 can be propagated (resent).	103
SCPTminSendTime / nciDigMinOutTm	Defines the minimum wait time before network output variables nvoDigSts1 ... nvoDigSts12 , nvoDigInput1 ... nvoDigInput12 , nvoDigOutput1 ... nvoDigOutput12 can be propagated (resent).	104
SCPTminSendTime / nciVsmdMinOutTm	Defines the minimum wait time before the network output variables can be propagated (resent)	104
SCPTminSetpoint / nciMinSpeed	Defines the minimum speed of the motor as a percentage of the nominal speed defined by the Nominal Speed (SCPTnomRPM / nciNmlSpeed) configuration value	105
SCPTnomFreq / nciNmlFreq	Sets the nominal frequency of the motor	105
SCPTnomRPM / nciNmlSpeed	Sets the nominal motor speed	106
SCPTrampDownTm / nciRampDownTm	Sets the ramp down time of the drive	106
SCPTrampUpTm / nciRampUpTm	Sets the ramp up time of the drive	107
UCPTbypRunDelay / nciBypRunDelay	Additional pick-up delay for bypass contactor *	107
UCPTdrvCurntLimit / nciDrvCurntLimit	Drive current limit	108
UCPTparReadIndex / nciParReadIndex	Chooses the parameter value to be read from the drive	108

Name	Description	More info on page
UCPTparValue / nciParWrite Value	Value input for the user selected parameter UCPTparWriteIndex / nciParWriteIndex	109
UCPTparWriteIndex / nciParWriteIndex	Defines the parameter value to be written to the drive	109
UCPTpid1DerFiltTime / nciPid1DerFiltTi, UCPTpid2DerFiltTime / nciPid2DerFiltTi	PID controller derivation filter times in seconds	110
UCPTpid1DerTime / nciPid1DerTime, UCPTpid2DerTime / nciPid2DerTime	PID controller derivation times in seconds	110
UCPTpid1Gain / nciPid1Gain, UCPTpid2Gain / nciPid2Gain	PID controller gain values in percent	111
UCPTpid1IntTime / nciPid1IntTime, UCPTpid2IntTime / nciPid2IntTime	PID controller integration times in seconds	112
UCPTstopLevel / nciStopLevel	Stop level value in the ramp stop mode	112
UCPTstopMode / nciStopMode	Selects between coast and ramp stop	113

* not for generic drive use

■ SCPTdefScale / nciDrvSpeedScale

Definition:

Network input config SNVT_lev_percent nciDrvSpeedScale

Explanation:

This variable shows the default value for *nviDrvSpeedScale*.

Valid range:

Value	Speed scaling
-32768	-163.840%
32766	163.830%
32767	Invalid

Default value:

The default value is 100%.

■ SCPTlocation / nciLocation

Definition:

Network input config SNVT_str_asc nciLocation

Explanation:

This variable provides Location Label; used to provide more descriptive physical location information than can be provided by the Neuron Chip's 6-byte location string.

Valid range:

Any NULL terminated ASCII string of 31 characters.

Default value:

The default value is empty spaces.

■ SCPTmaxRcvTime / nciAnlgRcvHrtBt

Definition:

Network config input SNVT_time_sec nciAnlgRcvHrtBt

Explanation:

This variable controls the maximum time that elapses after the last update of [nviAnlgCmd1](#) ... [nviAnlgCmd8](#) before the default values are used.

Valid range:

Value	Time
0	Disabled
1	0.1 s
65534	6553.4 s
65535	Invalid

Default value:

The default value is 0 (no failure detect).

■ SCPTmaxRcvTime / nciDigRcvHrtBt

Definition:

Network config input SNVT_time_sec nciDigRcvHrtBt

Explanation:

This variable controls the maximum time that elapses after the last update of [nviDigCmd1](#) ... [nviDigCmd12](#) before the default values are used.

Valid range:

Value	Time
0	Disabled
1	0.1 s
65534	6553.4 s
65535	Invalid

Default value:

The default value is 0 (no failure detect).

■ SCPTmaxRcvTime / nciVsmdRcvHrtBt

Definition:

Network config input SNVT_time_sec nciVsmdRcvHrtBt

Explanation:

This variable controls the maximum time that elapses after the last update of the network variables before the VSMD object starts to use its default values.

Valid range:

Value	Time
0	Disabled
1	0.1 s
65534	6553.4 s
65535	Invalid

Default value:

The default value is 0 (no failure detect).

■ SCPTmaxSendTime / nciAnlgSndHrtBt

Definition:

Network config input SNVT_time_sec nciAnlgSndHrtBt

Explanation:

This variable defines the maximum period of time that expires before network variables [nvoAnlgSts1 ... nvoAnlgSts8](#), [nvoAnlgInput1 ... nvoAnlgInput8](#), [nvoAnlgOutput1 ... nvoAnlgOutput8](#) will automatically be updated.

Valid range:

Value	Time
0	No automatic update
1	0.1 s
65534	6553.4 s
65535	Invalid

Default value:

The default value is 0 (no automatic update).

■ **SCPTmaxSendTime / nciDigSndHrtBt**
Definition:

Network config input SNVT_time_sec nciDigSndHrtBt

Explanation:

This variable defines the maximum period of time that expires before network variables *nvoDigSts1 ... nvoDigSts12*, *nvoDigInput1 ... nvoDigInput12*, *nvoDigOutput1 ... nvoDigOutput12* will automatically be updated.

Valid range:

Value	Time
0	No automatic update
1	0.1 s
65534	6553.4 s
65535	Invalid

Default value:

The default value is 0 (no automatic update).

■ SCPTmaxSendTime / nciVsmdSndHrtBt

Definition:

Network config input SNVT_time_sec nciVsmdSndHrtBt

Explanation:

This variable defines the maximum period of time that expires before the network variables will automatically be updated.

Valid range:

Value	Time
0	No automatic update
1	0.1 s
65534	6553.4 s
65535	Invalid

Default value:

The default value is 300 (automatic update every 5 minutes).

■ SCPTmaxSetpoint / nciMaxSpeed

Definition:

Network config input SNVT_lev_percent nciMaxSpeed

Explanation:

This variable is used to define the maximum motor speed. The value is entered as a percent of nominal speed, as defined by the Nominal Speed ([SCPTnomRPM](#) / [nciNmISpeed](#)) configuration value.

The value of the maximum speed must be defined so that

$-163.840 \leq \text{minimum speed} \leq \text{maximum speed} \leq 163.830$

Valid range:

Value	Maximum speed
-32768	-163.840%
32766	163.830%
32767	Invalid

Default value:

The default value is read from the host on power-up.

■ **SCPTminSendTime / nciAnlgMinOutTm**
Definition:

Network config input SNVT_time_sec nciAnlgMinOutTm

Explanation:

This variable defines the minimum wait time before network output variables *nvoAnlgSts1 ... nvoAnlgSts8*, *nvoAnlgInput1 ... nvoAnlgInput8*, *nvoAnlgOutput1 ... nvoAnlgOutput8* can be propagated (resent).

Valid range:

Value	Time
0	Disabled
1	0.1 s
65534	6553.4 s
65535	Invalid

Default value:

The default value is 0.5 s.

■ SCPTminSendTime / nciDigMinOutTm

Definition:

Network config input SNVT_time_sec nciDigMinOutTm

Explanation:

This variable defines the minimum wait time before network output variables *nvoDigSts1 ... nvoDigSts12*, *nvoDigInput1 ... nvoDigInput12*, *nvoDigOutput1 ... nvoDigOutput12* can be propagated (resent).

Valid range:

Value	Time
0	Disabled
1	0.1 s
65534	6553.4 s
65535	Invalid

Default value:

The default value is 0.5 s.

■ SCPTminSendTime / nciVsmdMinOutTm

Definition:

Network config input SNVT_time_sec nciVsmdMinOutTm

Explanation:

This variable defines the minimum wait time before the network output variables can be propagated (resent).

Valid range:

Value	Time
0	Disabled
1	0.1 s
65534	6553.4 s
65535	Invalid

Default value:

The default value is 15 s.

■ SCPTminSetpoint / nciMinSpeed

Definition:

Network config input SNVT_lev_percent nciMinSpeed

Explanation:

This variable defines the minimum speed of the motor as a percentage of the nominal speed defined by the Nominal Speed (*SCPTnomRPM / nciNmlSpeed*) configuration value.

The value of the minimum speed must be defined so that

$-163.840 \leq \text{minimum speed} \leq \text{maximum speed} \leq 163.830$

Valid range:

Value	Minimum speed
-32768	-163.840%
32766	163.830%
32767	Invalid

Default value:

The default value is read from host on power-up.

■ SCPTnomFreq / nciNmlFreq

Definition:

Network config input SNVT_freq_hz nciNmlFreq

Explanation:

This variable provides the nominal frequency of the motor in Hz.

Valid range:

Value	Nominal frequency
0	0 Hz
100	100 Hz

Default value:

The default value is read from the host on power-up/refresh.

■ SCPTnomRPM / nciNmISpeed

Definition:

Network config input SNVT_rpm nciNmISpeed

Explanation:

This variable provides the nominal motor speed in rpm. This value is necessary to determine the minimum and maximum speed for the motor, based on the configuration properties [SCPTminSetpoint / nciMinSpeed](#) and [SCPTmaxSetpoint / nciMaxSpeed](#).

Valid range:

Value	Nominal speed
0	0 rpm
65534	65534 rpm
65535	Invalid

Default value:

The default is read from the host on power-up/refresh.

■ SCPTrampDownTm / nciRampDownTm

Definition:

Network config input SNVT_time_sec nciRampDownTm

Explanation:

This variable provides the ramp down time of the motor.

Valid range:

Value	Ramp down time
0	0.0 s
65534	6553.4 s
65535	Invalid

Default value:

The default value is read from the host on power-up/refresh.

■ SCPTrampUpTm / nciRampUpTm

Definition:

Network config input SNVT_time_sec nciRampUpTm

Explanation:

This variable provides the ramp up time of the motor.

Valid range:

Value	Ramp up time
0	0.0 s
65534	6553.4 s
65535	Invalid

Default value:

The default is read from the host on power-up/refresh.

■ UCPTbypRunDelay / nciBypRunDelay

Definition:

Network input config SNVT_time_sec nciBypRunDelay

Explanation:

This sets the additional pick-up delay for the bypass contactor.

Valid Range:

Value	Pick-up delay
0	Disabled
1	0.1 s
65534	6553.4 s
65535	Invalid

Default Value:

The default is read from the host on power-up/refresh.

Note: This variable is not meant for generic drive use.

■ UCPTdrvCurntLimit / nciDrvCurntLimit

Definition:

Network input config SNVT_amp nciDrvCurntLimit

Explanation:

This variable sets the drive output current limit in amperes.

Valid Range:

Value	Current limit
0	0.0 A
32766	3276.6 A
0x7FFF	Invalid

Default Value:

The default value is read from the host on power-on/refresh.

■ UCPTparReadIndex / nciParReadIndex

Definition:

Network config input SNVT_count nciParReadIndex

Explanation:

This variable contains the parameter to read for [nvoParReadValue](#).

Valid range:

Value	Parameter value
0 ... 65535	Parameter-dependent

Default value:

The default value is 0.

■ UCPTparValue / nciParWriteValue

Definition:

Network config input SNVT_count_inc nciParWriteValue

Explanation:

This variable contains the value to be written to the parameter set by [UCPTparWriteIndex / nciParWriteIndex](#).

Valid range:

Value	Parameter value
0 ... 65534	Parameter-dependent
0xFFFF	Invalid

Default value:

The default value is 0.

■ UCPTparWriteIndex / nciParWriteIndex

Definition:

Network config input SNVT_count nciParWriteIndex

Explanation:

This variable contains the parameter to write for [UCPTparValue / nciParWriteValue](#).

Valid range:

Value	Parameter value
0 ... 65535	Parameter-dependent

Default value:

The default value is 0.

■ UCPTpid1DerFiltTime / nciPid1DerFiltTi, UCPTpid2DerFiltTime / nciPid2DerFiltTi

Definition:

Network config input SNVT_time_sec nciPid1DerFiltTi
Network config input SNVT_time_sec nciPid2DerFiltTi

Explanation:

This variable shows the PID controller derivation filter times in seconds.

Valid range:

Value	Filter time
0	0 s
1	0.1 s
65535	6553.5 s
65537	Invalid

Default value:

The default value is read from the host on power-on/refresh.

■ UCPTpid1DerTime / nciPid1DerTime, UCPTpid2DerTime / nciPid2DerTime

Definition:

Network config input SNVT_time_sec nciPid1DerTime
Network config input SNVT_time_sec nciPid2DerTime

Explanation:

This variable shows the PID controller derivation times in seconds.

Valid range:

Value	Derivation time
0	0 s
1	0.1 s
65535	6553.5 s
65537	Invalid

Default value:

The default value is read from the host on power-on/refresh.

■ UCPTpid1Gain / nciPid1Gain, UCPTpid2Gain / nciPid2Gain

Definition:

Network config input SNVT_lev_percent nciPid1Gain

Network config input SNVT_lev_percent nciPid2Gain

Explanation:

This variable provides the PID controller gain values.

Valid Range:

Value	Gain
-32768	-163.84%
32766	163.83%
32767	Invalid

Default Value:

The default is read from the host on power-on/refresh.

■ UCPTpid1IntTime / nciPid1IntTime, UCPTpid2IntTime / nciPid2IntTime

Definition:

Network config input SNVT_time_sec nciPid1IntTime

Network config input SNVT_time_sec nciPid2IntTime

Explanation:

This variable shows the PID controller integration times in seconds.

Valid range:

Value	Time
0	0 s
1	0.1 s
65535	6553.5 s
65537	Invalid

Default value:

The default is read from the host on power-on/refresh.

■ UCPTstopLevel / nciStopLevel

Definition:

Network config input SNVT_lev_percent nciStopLevel

Explanation:

This variable provides the stop level value in the ramp stop mode. When the speed of the drive reaches this level, a coast stop is performed. The value corresponds to *nvoDrvSpeed*, ie, the value of 5% causes a coast stop when *nvoDrvSpeed* reaches 5%.

Valid range:

Value	Stop level
-32768	-163.84%
32766	163.83%
32767	Invalid

Default value:

The default value is 5%.

■ **UCPTstopMode / nciStopMode**
Definition:

Network config input SNVT_switch nciStopMode

Explanation:

This variable is used to select between coast and ramp stop.

Valid range:

State	Value	Stop mode
0	0.0	Coast
1	100	Ramp

Default value:

The default value is Coast (state 0, value 0.0).



Diagnostics

What this chapter contains

This chapter explains how to trace faults with the status LEDs on the adapter module.

Fault and warning messages

For the fault and warning messages concerning the adapter module, see the drive firmware manual.

LED indications

The adapter module is equipped with three diagnostic LEDs. The LEDs are described below.

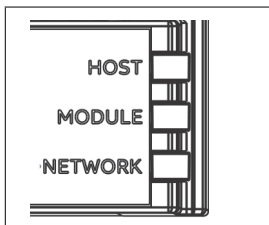

Name	Color	Function
HOST	Green	Communication to host ok
	Blinking red	Establishing communication to host, or communication to host lost
MODULE	Off	Off/Initializing/Invalid
	Red	Unconfigured (with or without application)
	Yellow	Configured – offline (hard, soft or bypass)
	Blinking yellow	Configured – online (with receive timeout)
	Blinking green	Wink
	Green	Configured – online
NETWORK	Yellow	Transmitting
	Green	Receiving
	Off	Inactive

10

Technical data

What this chapter contains

This chapter contains the technical specifications of the adapter module and the LONWORKS[®] network.

FLON-01

The below figure shows the enclosure of the adapter module from the front and side.

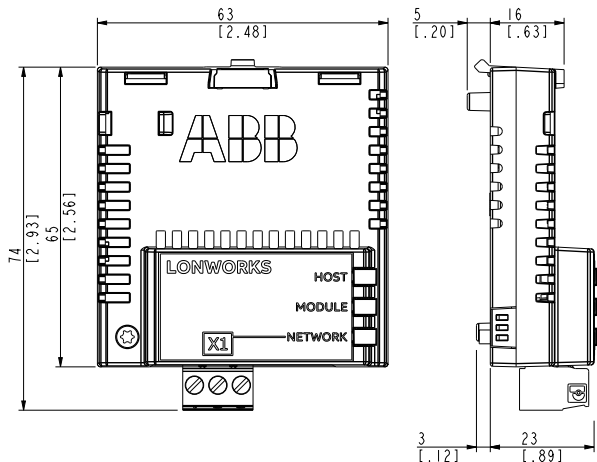

Mounting	Into the option slot of the drive
Degree of protection	IP20
Ambient conditions	Applicable ambient conditions specified for the drive in its manuals are in effect.
Indicators	Three bicolor LEDs (HOST, MODULE, NETWORK)
Connectors	20-pin connector to the drive (X2) 3-pole detachable screw terminal block (X1)
Power supply	Input voltage: From the drive: +3.3 V DC (+/- 5%)
General	Complies with EMC standard EN 61000-6-4:2001 and EN 61800-3:2004. Bus interface functionally isolated from the drive.

LONWORKS[®] network

Compatible devices	All devices equipped with FT-X1 and FTT-10A compatible transceivers
Size of the network	32385 nodes divided into 127 nodes / subnet with 255 subnets / domain
Medium	<ul style="list-style-type: none"> Termination: 105 Ω / 52.5 Ω, depending on the network topology. See Connecting the module to the LONWORKS[®] network on page 26. Cable specifications: See the following tables.

LONWORKS[®] network cable specifications

	Control / signaling grade 16 AWG (1.3 mm)	General purpose grade 16 AWG (1.3 mm)	Data grade level 4 22 AWG (0.65 mm)	JY (St) Y 2×2×0.8 20.4 AWG (0.8 mm)
Max DC resistance at 20 °C loop	28.2 Ω /km	28.2 Ω /km	118 Ω /km	74.0 Ω /km
Max DC resistance unbalance			5%	
Max mutual capacitance of a pair	58 nF/km	74 nF/km	56 nF/km	100 nF/km
Max pair-to-ground capacitance unbalance			3.28 nF/km	
Nominal impedance	95 Ω at 1.0 MHz	100 Ω at 1.0 MHz	102 Ω \pm 15% at 772 kHz 100 Ω \pm 15% at 1, 4, 8, 10, 16 and 20 MHz	

	Control / signaling grade 16 AWG (1.3 mm)	General purpose grade 16 AWG (1.3 mm)	Data grade level 4 22 AWG (0.65 mm)	JY (St) Y 2×2×0.8 20.4 AWG (0.8 mm)
Max attenuation at 20 °C			15 dB/km at 772 kHz 18 dB/km at 1.0 MHz 36 dB/km at 4.0 MHz 49 dB/km at 8.0 MHz 56 dB/km at 10.0 MHz 72 dB/km at 16.0 MHz 79 dB/km at 20.0 MHz	
Pair twists per metre	20 (nominal)	20 (minimum)		5 (minimum)
Cable parameters	single twisted pair stranded 19/29 unshielded Tefzel Insulation & Jacket High 150 °C max	single twisted pair stranded 19/29 unshielded PVC Insulation & Jacket Medium 80 °C max	twisted pair, single or multiple typically solid and unshielded	wire pair: red/black per DIN VDE 0815 4-wire helical twist solid shielded

LONWORKS[®] network, maximum bus lengths

		Control / signalling grade 16 AWG (1.3 mm)	General purpose grade 16 AWG (1.3 mm)	Data grade level 4 22 AWG (0.65 mm)	JY (St) Y 2×2×0.8 20.4 AWG (0.8 mm)
Doubly terminated bus topology	Bus length	2200 m	2200 m	1150 m	750 m
	Stub length	3 m	3 m	3 m	3 m
Singly-terminated free topology	Node-to-node distance	500 m	400 m	400 m	320 m
	Total wire length	500 m	500 m	500 m	500 m

Topology	Supports free topology wiring, and will accommodate bus, star, loop, or any combination of these topologies
Transfer rate	78 kbit/s
Serial communication type	Asynchronous, Half duplex
Protocol	LonTalk [®]
Documents	LONMARK [®] Layers 1-6 Interoperability Guidelines, version 3.4

11

Appendix – Compatibility table

What this chapter contains

This chapter lists the network variables that are used with the drives compatible with the adapter module.

Supported network variables in alphabetical order

The following table lists the network variables that are used with the drives compatible with the adapter module.

Note: Bypass Firmware version (bypass parameter 3301) 1.01B or later is required with E-Clipse + ACH550.

Network variable	E-Clipse + ACH550	ACS355	ACS850/ ACQ810	ACH580
nciAnlgMinOutTm	x		x	x
nciAnlgRcvHrtBt	x		x	x
nciAnlgSndHrtBt	x		x	x
nciBypRunDelay	x			
nciDigMinOutTm	x		x	x
nciDigRcvHrtBt	x		x	x
nciDigSndHrtBt	x		x	x
nciDrvCurntLimit	x		x	x
nciDrvSpeedScale	x	x	x	x
nciLocation	x	x	x	x
nciMaxSpeed	x		x	x
nciMinSpeed	x		x	x
nciNmlFreq	x	x	x	x
nciNmlSpeed	x	x	x	x
nciParReadIndex	x	x	x	x
nciParWriteIndex	x	x	x	x
nciParWriteValue	x	x	x	x
nciPid1DerFiltTi	x		x	x
nciPid1DerTime	x		x	x
nciPid1Gain	x		x	x
nciPid1IntTime	x		x	x
nciPid2DerFiltTi	x			

Network variable	E-Cclipse + ACH550	ACS355	ACS850/ ACQ810	ACH580
nciPid2DerTime	x			
nciPid2Gain	x			
nciPid2IntTime	x			
nciRampDownTm	x	x	x	x
nciRampUpTm	x	x	x	x
nciStopLevel	x	x	x	x
nciStopMode	x	x	x	x
nciVsmdMinOutTm	x	x	x	x
nciVsmdRcvHrtBt	x	x	x	x
nciVsmdSndHrtBt	x	x	x	x
nviAnlgCmd_1	x			x
nviAnlgCmd_2	x			x
nviAnlgCmd_3	x			
nviAnlgCmd_4	x			
nviAnlgCmd_5	x			
nviAnlgCmd_6	x			
nviAnlgCmd_7	x			
nviAnlgCmd_8				
nviCtlOverrideCm	x	x	x	x
nviDigCmd_1	x			x
nviDigCmd_10	x			
nviDigCmd_11	x			
nviDigCmd_12	x			
nviDigCmd_2	x			x
nviDigCmd_3	x			x
nviDigCmd_4	x			x
nviDigCmd_5	x			x
nviDigCmd_6	x			x

Network variable	E-Clipse + ACH550	ACS355	ACS850/ ACQ810	ACH580
nviDigCmd_7	x			
nviDigCmd_8	x			
nviDigCmd_9	x			
nviDrvProcStpt	x	x	x	x
nviDrvSpeedScale	x	x	x	x
nviDrvSpeedStpt	x	x	x	x
nviEmrgOvrd	x	x	x	x
nviExt1Ext2Ctrl	x	x	x	x
nviLocLock	x	x		
nviRequest	x	x	x	x
nviResetFault	x	x	x	x
nviRunEnable	x	x	x	x
nviSavePars	x	x	x	x
nviStartEnable1	x	x		x
nviStartEnable2	x	x		x
nvoAccelerating	x	x		x ¹⁾
nvoAlarm	x	x	x	x
nvoAnlgInput_1	x			x
nvoAnlgInput_2	x			x
nvoAnlgInput_3				
nvoAnlgInput_4				
nvoAnlgInput_5				
nvoAnlgInput_6				
nvoAnlgInput_7				
nvoAnlgInput_8				
nvoAnlgOutput_1	x			x
nvoAnlgOutput_2	x			x
nvoAnlgOutput_3				

Network variable	E-Clipse + ACH550	ACS355	ACS850/ ACQ810	ACH580
nvoAnlgOutput_4				
nvoAnlgOutput_5				
nvoAnlgOutput_6				
nvoAnlgOutput_7				
nvoAnlgOutput_8				
nvoAnlgSts_1	x			
nvoAnlgSts_2	x			
nvoAnlgSts_3	x			
nvoAnlgSts_4				
nvoAnlgSts_5				
nvoAnlgSts_6				
nvoAnlgSts_7				
nvoAnlgSts_8				
nvoAtReference	x	x	x	x
nvoBypKwh_R	x			
nvoBypRunHours	x			
nvoBypTemp	x			
nvoCtlOverrideSt	x	x	x	x
nvoDecelerating	x	x		x ¹⁾
nvoDigInput_1	x			x
nvoDigInput_10	x			
nvoDigInput_11	x			
nvoDigInput_12	x			
nvoDigInput_2	x			x
nvoDigInput_3	x			x
nvoDigInput_4	x			x
nvoDigInput_5	x			x
nvoDigInput_6	x			x

Network variable	E-Clipse + ACH550	ACS355	ACS850/ ACQ810	ACH580
nvoDigInput_7	x			
nvoDigInput_8	x			
nvoDigInput_9	x			
nvoDigOutput_1	x			x
nvoDigOutput_10				
nvoDigOutput_11				
nvoDigOutput_12				
nvoDigOutput_2	x			x
nvoDigOutput_3	x			x
nvoDigOutput_4	x			x
nvoDigOutput_5	x			x
nvoDigOutput_6	x			x
nvoDigOutput_7	x			
nvoDigOutput_8	x			
nvoDigOutput_9				
nvoDigSts_1	x			
nvoDigSts_10				
nvoDigSts_11				
nvoDigSts_12				
nvoDigSts_2	x			
nvoDigSts_3				
nvoDigSts_4				
nvoDigSts_5				
nvoDigSts_6				
nvoDigSts_7				
nvoDigSts_8				
nvoDigSts_9				
nvoDrvCumt	x	x	x	x

Network variable	E-Cclipse + ACH550	ACS355	ACS850/ ACQ810	ACH580
nvoDrvDCBus	x	x	x	x
nvoDrvKwh_NR	x	x		x
nvoDrvKwh_R	x		x	x
nvoDrvPwr	x	x	x	x
nvoDrvRunHours	x	x	x	x
nvoDrvSpeed	x	x	x	x
nvoDrvTemp	x	x		
nvoDrvTorque	x	x	x	x
nvoDrvVolt	x	x		x
nvoEmrgOvrStat	x	x	x	x
nvoEnabled	x	x	x	x
nvoExt1Ext2Stat	x	x	x	x
nvoFaultCode	x	x	x	x
nvoFaulted	x	x	x	x
nvoForward	x	x	x	x
nvoFreqAct	x	x	x	x
nvoLimit	x	x	x	x
nvoLineUVVolt	x			
nvoLineVolt	x			
nvoLineWUVolt	x			
nvoLineVWVolt	x			
nvoLocRemStat	x	x	x	x
nvoMtrRevCntM	x			
nvoMtrTemp	x	x	x	x
nvoNetCtrl	x	x	x	x
nvoNetRef1	x	x		x ²⁾
nvoNetRef2	x	x		x ²⁾
nvoParReadValue	x	x	x	x

Network variable	E-Clipse + ACH550	ACS355	ACS850/ ACQ810	ACH580
nvoPid1Dev	x		x	x
nvoPid1Fbk	x		x *	x
nvoPid2Dev	x			
nvoPid2Fbk	x			
nvoReady	x	x	x	x
nvoReverse	x	x	x	x
nvoRunning	x	x	x	x
nvoSpeedActRpm	x	x	x	x
nvoStarted	x	x	x	x
nvoStatus	x	x	x	x
nvoZeroSpeed	x	x	x	x

1) Variable is set to true when drive is either accelerating or decelerating.

2) nvoNetRef1 and nvoNetRef2 variables indicate that the LONWORKS® network is selected as the active reference REF1 or REF2 source.

Further information

Product and service inquiries

Address any inquiries about the product to your local ABB representative, quoting the type designation and serial number of the unit in question. A listing of ABB sales, support and service contacts can be found by navigating to abb.com/searchchannels.

Product training

For information on ABB product training, navigate to new.abb.com/service/training.

Providing feedback on ABB manuals

Your comments on our manuals are welcome. Navigate to new.abb.com/drives/manuals-feedback-form.

Document library on the Internet

You can find manuals and other product documents in PDF format on the Internet at abb.com/drives/documents.



abb.com/drives
abb.com/solar
abb.com/windconverters
abb.com/drivespartners



3AJA0000041017C