

**AIR MONITOR
CORPORATION**

INSTALLATION PROCEDURE

ELECTRA-flo/FI

INSPECTION & HANDLING. The ELECTRA-flo/FI should be carefully inspected for damage prior to installation. Report damage to your Freight Department, or contact delivery carrier.

These units may be handled while in any position. However, it is important not to drop or mishandle the units such that damage is done to sensing holes, connection fittings, or the swivel mounting brackets on the ends of each mounting strut.

WARRANTY

Air Monitor Corporation (hereinafter referred to as "Seller") warrants that at the time of shipment, products sold pursuant to this contract will be free from defects in materials and workmanship, and will conform to the specifications furnished or approved in writing by Seller. No warranty is given that delivered products will conform to catalog sheets, data sheets, and the like, which are subject to change without notice.

Seller will repair or replace, at its option, any products listed under this warranty which is returned freight pre-paid to Seller and within the earlier of three (3) years after start-up or thirty-nine (39) months after shipment, prove upon test and examination by Seller to be defective within the terms of this warranty. The warranty period for any item repaired or replaced shall be for the time remaining on the warranty period for the original components. Purchaser shall notify Seller in writing of such defect within sixty (60) days of discovery of the defect.

This warranty does not extend to any product sold by Seller which has been the subject of misuse, neglect, accident, damage or malfunction caused by interconnection with equipment manufactured by others, improper installation or storage, or used in violation of instructions furnished by Seller, nor does it extend to any product which has been repaired or altered by persons not expressly approved by Seller.

Seller shall not be liable for any special or consequential damages or for loss of damage directly or indirectly arising from the use of the products.

The warranty set forth above is in lieu of all other warranties either express or implied and constitutes the full extent of Air Monitor Corporation's liability to the customer, or any other party for breach of warranty. THERE ARE NO EXPRESS WARRANTIES EXCEPT AS SET FORTH HEREIN. THERE ARE NO IMPLIED WARRANTIES OF MERCHANTABILITY OR FITNESS FOR ANY PARTICULAR PURPOSE, WHICH ARE PARTICULARLY DISCLAIMED.

ELECTRA-flo/FI – Installation Procedure

LOCATION OF PROBES

- The ELECTRA-flo/FI probe assembly must be located within the smallest diameter portion of the fan inlet bell.
- Contact Air Monitor's Applications Engineering Department for guidance when the intended installation location is not accessible or is obstructed.
- The levels of air filtration and cleanliness associated with commercial HVAC systems are satisfactory for the ELECTRA-flo/FI. Applications containing airborne contaminants or condensing moisture may impair measurement accuracy and functionality.

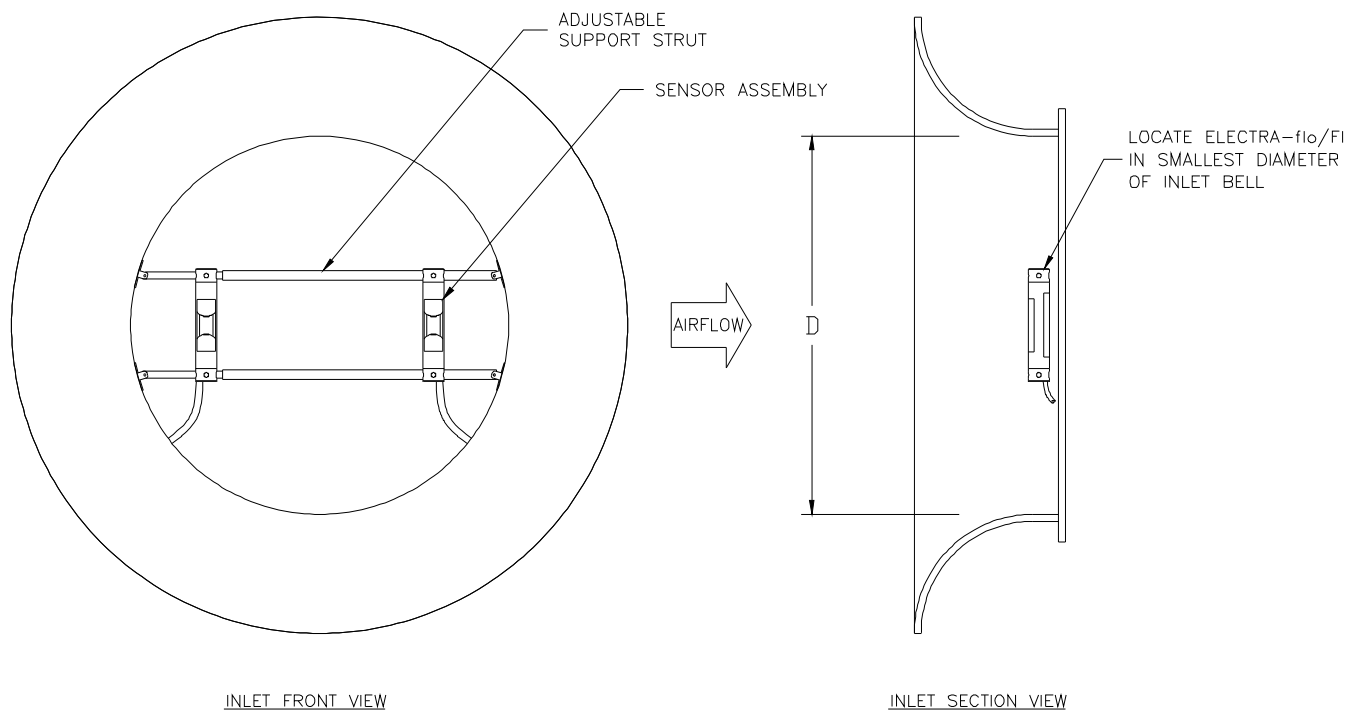

ELECTRA-flo/FI – Installation Procedure

PROBE ASSEMBLY INSTALLATION.

- The probes and support struts for a fan inlet are pre-assembled at the Factory. The probe assembly and the associated transmitter for a particular fan inlet can be identified by means of the **ESID #** on the end of each probe, the transmitter package, and transmitter itself. See Figure A below for probe assembly detail.

The ESID # on the Transmitter and on the Probe(s) must match.
DO NOT MIX AND MATCH
Confirm the number of Probes needed for each Transmitter by
referring to the provided Factory Set-Up Sheet.

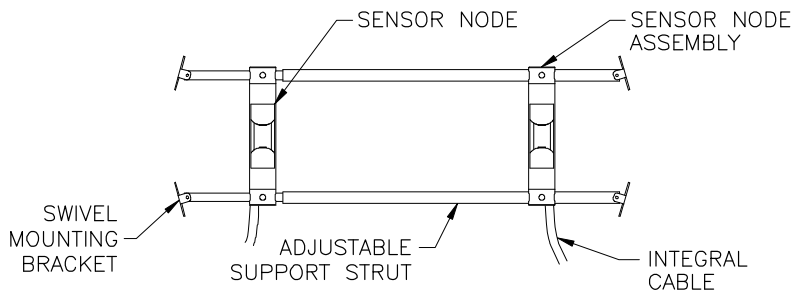

Figure A

- Each probe has an airflow arrow to assist in correct installation relative to the direction of air flow in the duct.
- If the fan has a shaft at the inlet area where the ELECTRA-flo/FI probe assembly will be mounted, it will be necessary to separate the probe assembly into two sections and then re-assemble it around the shaft.
- Position the probe assembly in the smallest diameter portion of the fan inlet bell, being sure that the assembly is kept vertical (not leaning in/out relative to the inlet). Mark the locations of the eight mounting holes.
- It is recommended that the probe assembly be secured to the inlet using 8-32 or 10-32 machine screws and lock nuts, not sheetmetal screws. (Note: Fasteners are not provided.) See Figure B below for mounting detail.

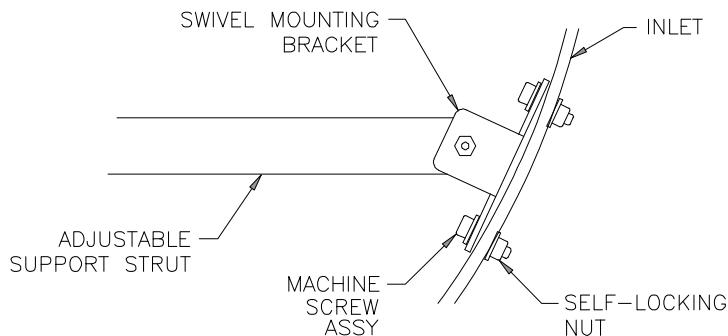

Figure B

- Position the two sensor nodes and secure them in place by means of the set screw on each end. Each node should be positioned so that there is “y” inches between the centerline of the node and the inside of the fan inlet, where:

$$y = 20\% \text{ of the inlet diameter}$$

- If the fan has a dual inlet, repeat the above steps for the other fan inlet.

ELECTRA-flo/FI – Installation Procedure

CABLE CONNECTIONS.

- Each probe has an integral cable terminated with a positive locking plug-in connector. The standard cable length is 10', unless the optional 50' or 100' long cables were ordered.
- Secure the cables to the sensor support struts with wire ties, then route the inlet housing with the cables secured to the inlet surface.
- If the fan has a single inlet, then the two connection cables (one per sensor) will plug into the provided junction box which needs to be mounted in a location reachable by all four connection cables. See Figure C below.

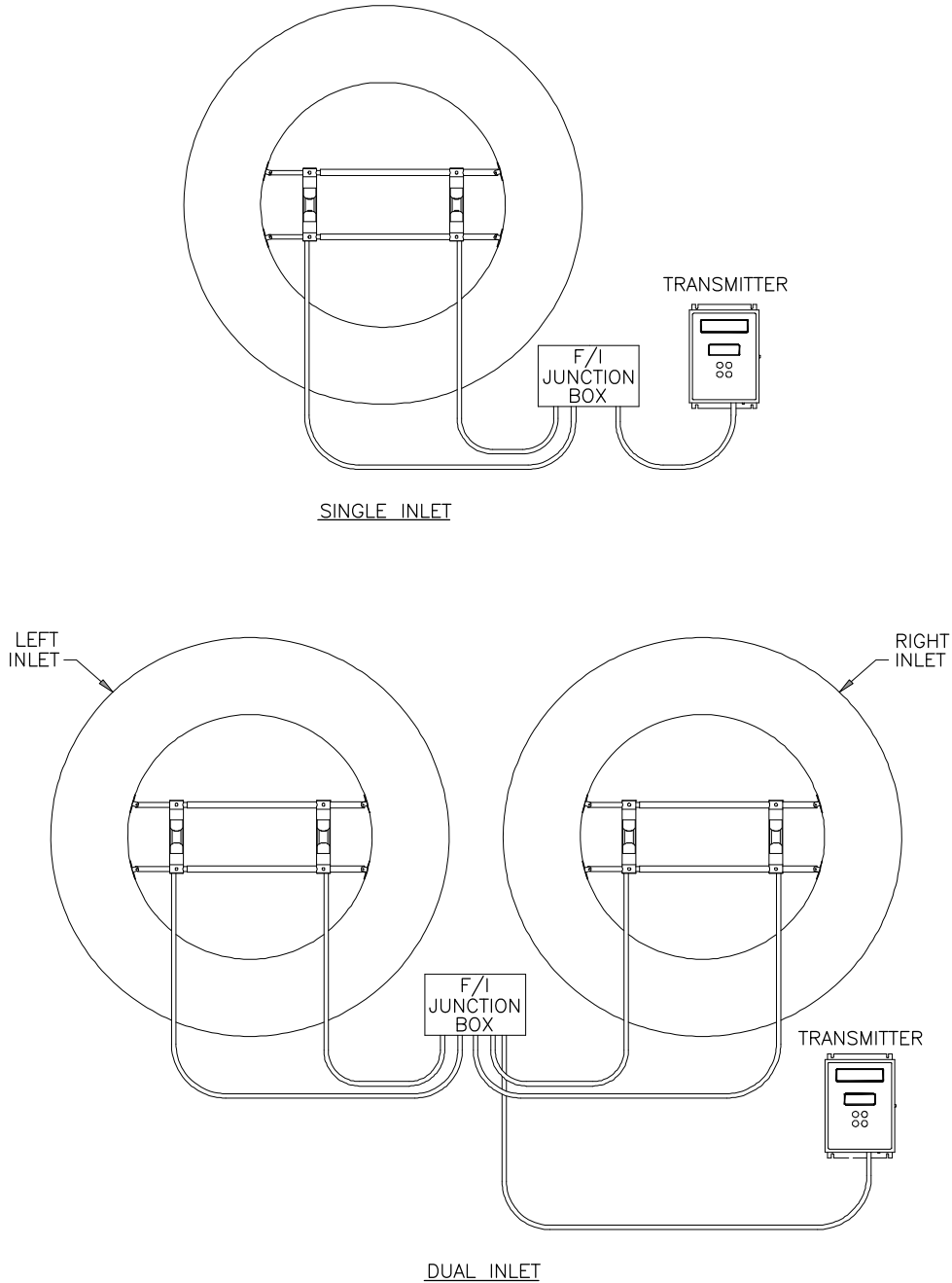

Figure C

ELECTRA-flo/FI – Installation Procedure

TRANSMITTER INSTALLATION.

- The transmitter must be located so that the single cable from the probe array will reach the receptacle in the bottom of the transmitter. Standard cable length is 10', with optional 50' and 100' cables available.
- Mount the transmitter to a vertical surface in an upright position. Avoid locations subject to excessive amounts of vibration.
- The transmitter's enclosure has a NEMA 1 rating, requiring that it be mounted in a moderately clean indoor environment with temperature ranges between -20°F and 140°F .
- Consult the ELECTRA-flo Transmitter O&M manual for details related to power and signal wire connections, configuration options, and start-up.
- See Figure D for transmitter dimensions and installation clearances.

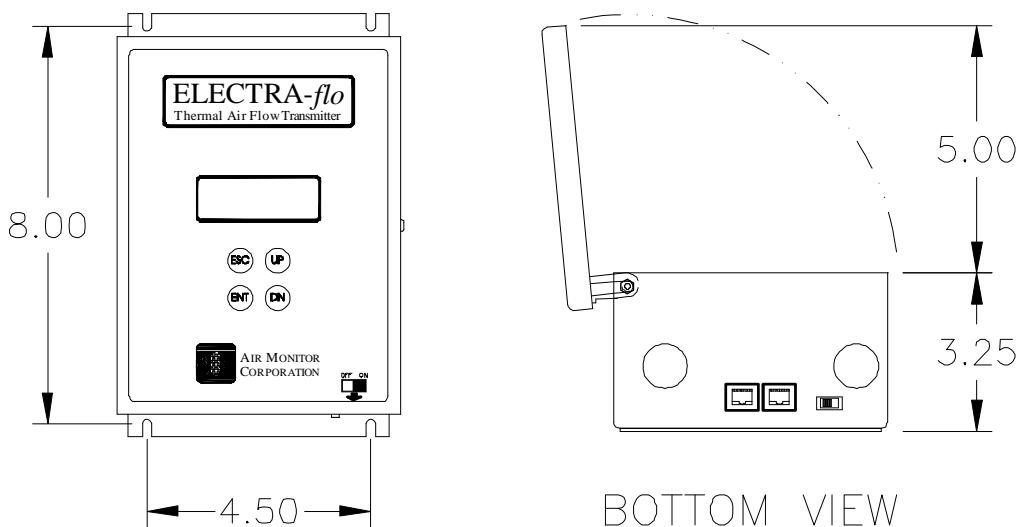

Figure D

ELECTRA-flo/FI – Installation Procedure

CUSTOMER SERVICE. Air Monitor Corporation provides in-house technical support for all our products:

Monday through Friday, 7 am to 5 pm (pst)
Phone: 707-544-2706 or 1-800-AIRFLOW / Fax: 707-526-2825

If after contacting the Customer Service Department it is determined that equipment will require return to Air Monitor Corporation for further repair, a Return Authorization number will be issued. A Confirmation of Return Authorization with shipping instructions will be sent via facsimile or e-mail. Equipment to be returned to Air Monitor should be returned in its original shipping container if possible. If this is not possible, ensure equipment is packaged sufficiently to protect it during shipment.

Caution: All damage occurring during transit is the Customer's responsibility.

List the Return Authorization (R/A) number on the packing list and clearly mark this number on the outside of each shipping container. Costs associated with the return of equipment to Air Monitor Corporation are the customer's responsibility regardless whether the repair/return is under warranty. Once the Customer Service Department determines that the equipment repair is under warranty, the item will be repaired and returned to the customer at no charge. If the equipment is not under warranty, customer will need to approve a repair quote which will be invoiced along with return shipping charges.

