

## Data sheet

# Automatic balancing valves

## ASV

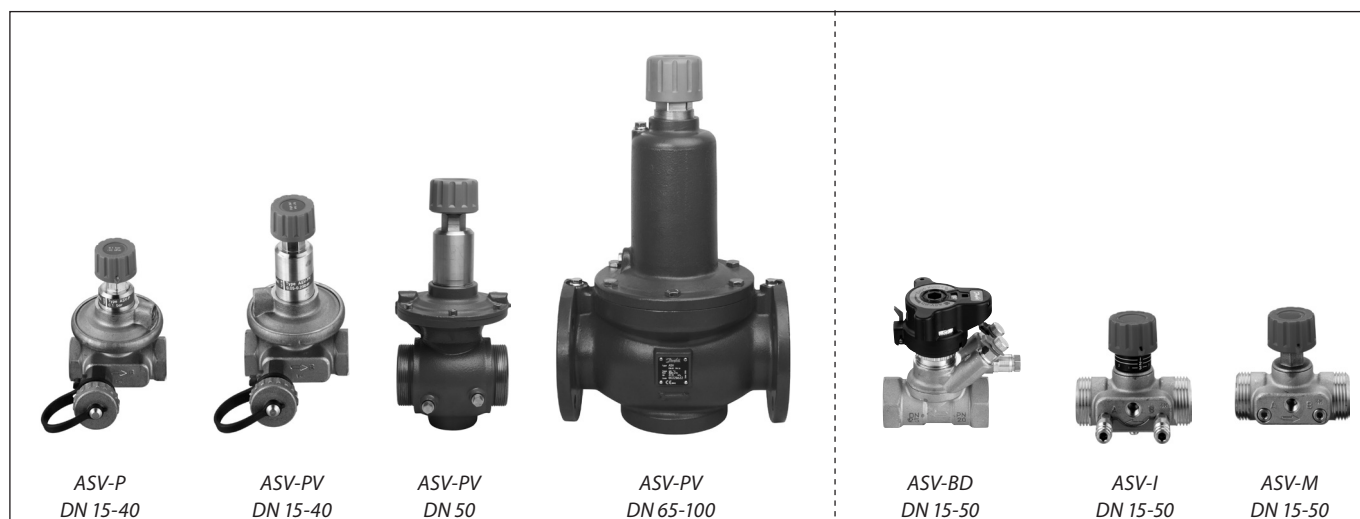

### Description / Application

ASV balancing valves are used for dynamic hydronic balance in heating and cooling systems. Dynamic balancing means: permanent balancing from 0 to 100 % load by controlling the pressure in systems with variable flow. At partial loads, when the flow is decreased by the control valve, pressure limitation is still performed and consequently performing dynamic balancing. By using ASV you avoid using complex and time consuming commissioning methods. Dynamic balancing of the system in all loads helps you to save energy and improves climate comfort and control.

#### Flow limitation

By using combination of pressure controller ASV and settable terminal's unit valve, flow limitation is established.

Flow limitation for each terminal unit prevents underflows on distant units and overflows on others thus allows efficient pumping.

#### Lower noise emission

Differential pressure limitation provides the pressure over the control valve not to increase at partial loads thus noise emission will be lower. (This is the reason why DIN 18380 requires control of differential pressure by partial load.)

#### No balancing method needed

Flow limitation is achieved by adjusting each hydronic loop separately without influencing others, which consequently results in one time adjusting process. No special balancing method is needed so commissioning cost can be saved.

#### Control valve authority

Controlling differential pressure over the control valve means that authority is high – which allows an accurate and stable control as well as energy saving.

### Zone balancing

By installing the ASV sets you can divide the piping system in pressure independent zones. This allows a gradual connection of zones to the main in new constructions or at renovation without using an additional balancing method. There is no need to perform a new commissioning every time the system is changed because the hydronic balance is done automatically.

ASV-P valves have fixed setting (10 kPa). The setting can be increased to 20 or 30 kPa by spring replacement. Spring can be replaced under pressure. The ability to increase the setting is especially useful in case of trouble shooting. It gives insurance that design flow can be achieved even if calculation doesn't match actual installation.

ASV-PV valves are settable in different ranges:

- 5-25 kPa setting is mostly used for radiator application,
- 20-60 kPa setting is used for floor heating, fan coil, chilled beam and flat station applications,
- 35-75 kPa setting is used for flat station and fan coil, chilled beam application,
- 60-100 kPa setting is used for large terminal unit application (air handling units, fan coils, etc.).

Using ASV valves it is possible to optimize pump head while independent pressure zones allow to keep authority of terminal unit's valve high.

**Description / Application**  
(continuous)

ASV balancing valves are designed to guarantee high quality of the automatic balancing by:

- a pressure released cone,
- an adapted membrane for every valve dimension which provide constant quality performance for all sizes,
- spring with linear characteristic that makes setting required  $\Delta p$  easy.

A 90° angle between all service features (shut-off, draining, setting, measuring) allows an easy access under any installing condition.

All the above-mentioned features and functions are realized in small build-in dimensions so it is easy to install ASV even in very limited space.

ASV valves are performing pressure control not only at design conditions (100 % load) but also at all partial loads (thus fulfilling the requirements of DIN 18380 norms). By controlling pressure at a partial load one can prevent noise problems on thermostatic radiator valves which often occur in unbalanced systems.

ASV valves (DN 15-40) are packaged in styropore (EPS) which can be used for insulation at

temperatures up to 80 °C. An insulation cap is available as an accessory for insulation at higher temperatures (up to 120 °C).

ASV valves in dimensions DN 15-40 are supplied with an internal or external thread while DN 50 is supplied with external thread only. If an external thread is chosen, a threaded or weld plug can be supplied as an accessory. Dimensions DN 65-100 are supplied as flanged valves.

ASV balancing valves have integrated service functions such as shut-off and draining.

ASV-PV can be equipped with plug for flow measuring. In that case measuring plugs need to be ordered separately and mounted on the valve as follows:

- on top of drain connection (DN 15-50),
- on the flange connection before the valve is filled with water (DN 65-100).

ASV-PV valves are to be mounted in return pipe, in combination with partner valves mounted in flow pipe. As a partner valve ASV-M/I/BD are recommended for dimensions DN 15 to DN 50 and MSV-F2 for dimensions DN 65 to DN 100.

There are two basic configurations when using ASV partner valves (ASV-BD, ASV-I, ASV-M, MSV-F2):

- partner valve **outside the control loop** (Fig. 1). Recommended configuration: it results in best performance since whole controlled pressure range is available to the riser. Flow limitation is done on each terminal unit in the riser (for example, RA-N with presetting on radiator, etc).

DN 15 to DN 50: ASV-M or ASV-BD  
DN 65 to DN 100: MSV-F2, by connecting impulse tube to down-flow test plug.

- partner valve **inside control loop** (Fig. 2). Offers flow limitation on the riser however part of the controlled pressure range is used by pressure drop on partner valve ( $\Delta p_i$ ). It is recommended when flow limitation on each terminal units is not possible.

DN 15 to DN 50: ASV-I or ASV-BD.  
DN 65 to DN 100: MSV-F2, by connecting impulse tube to up-flow test plug.

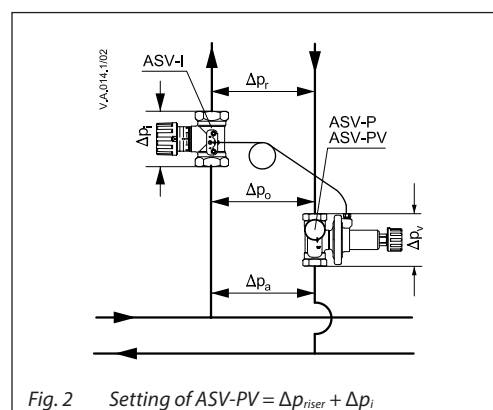
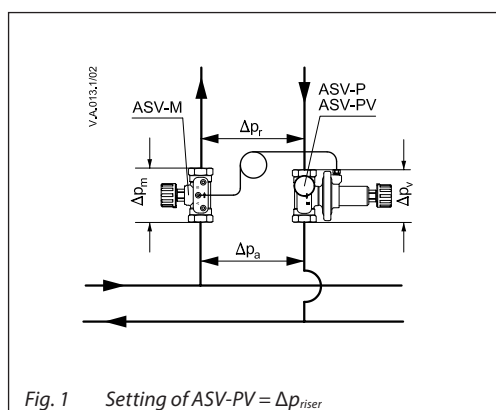

ASV-BD can be used outside or inside control loop by choice of which test plug is open. To be used outside control loop, **blue** test plug needs to be open. In this position, flow verification can be done (**default** position). To be used inside control loop, red test plug needs to be open. In this position, flow verification & flow verification can be done.

Description / Application  
(continuous)

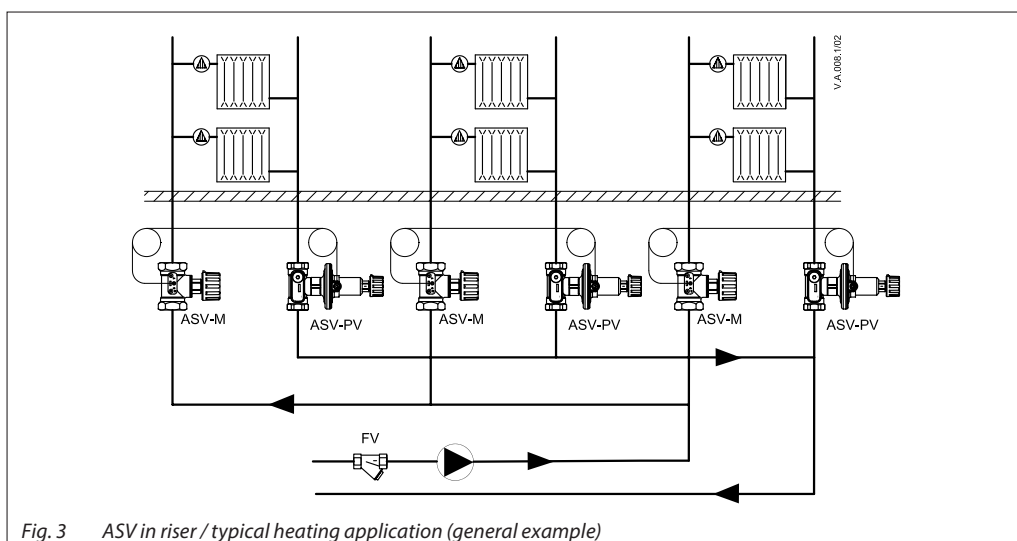

Fig. 3 ASV in riser / typical heating application (general example)

ASV valves are to be used in radiator heating systems to control the differential pressure in risers. To limit the flow for every radiator, the thermostatic radiator valve with pre-setting facilities (feature) is used together with a constant pressure provided by the ASV, thus providing balanced heat distribution.

Alternatively the flow in the riser can be limited by using setting function of the ASV-I. Controlling differential pressure over the riser means also that the valve authority over the thermostatic radiator valves is high – which allows an accurate and stable temperature control and saves energy.

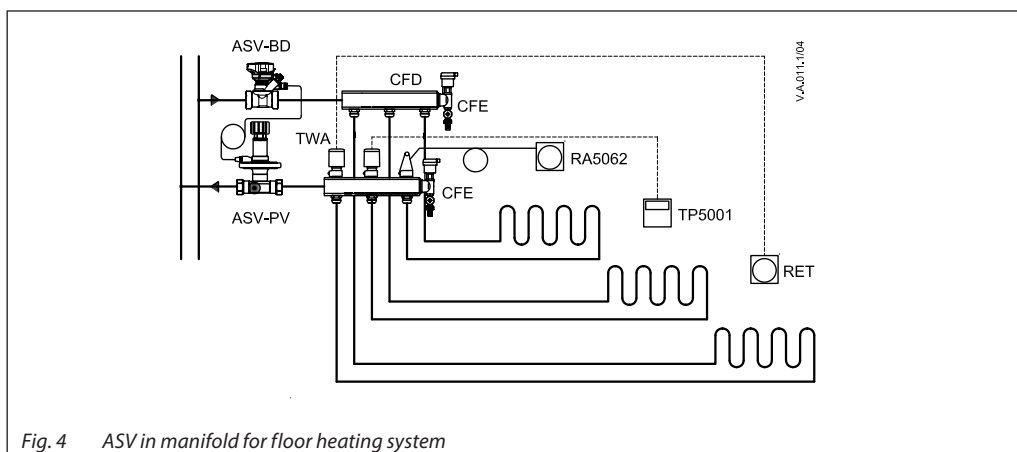

Fig. 4 ASV in manifold for floor heating system

ASV valves are to be used in floor heating systems. To limit the flow for every loop valves with an integrated flow limiting or presetting function should be used together with a constant pressure provided by an ASV-PV valve. Alternatively the flow for the whole manifold can be limited by using the setting function of the ASV-I or ASV-BD.

ASV-PV valves can control the differential pressure in several ranges if different pressure is needed. Due to its small dimensions the ASV automatic balancing valves are easy to install in a wall mounted box for floor heating manifolds.

**Description / Application**  
(continuous)

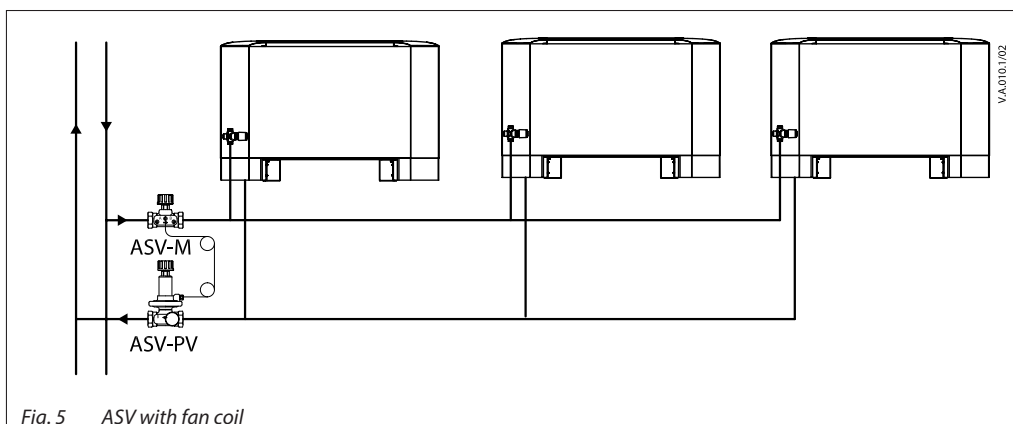

Fig. 5 ASV with fan coil

The ASV valves are to be used in systems with fan coils, induction devices and air-heaters to secure an automatic hydronic balance by the means of differential pressure control in branches or at every coil. Constant differential pressure in combination with pre-set control valves i.e. ASV-I or ASV-BD limits the flow.

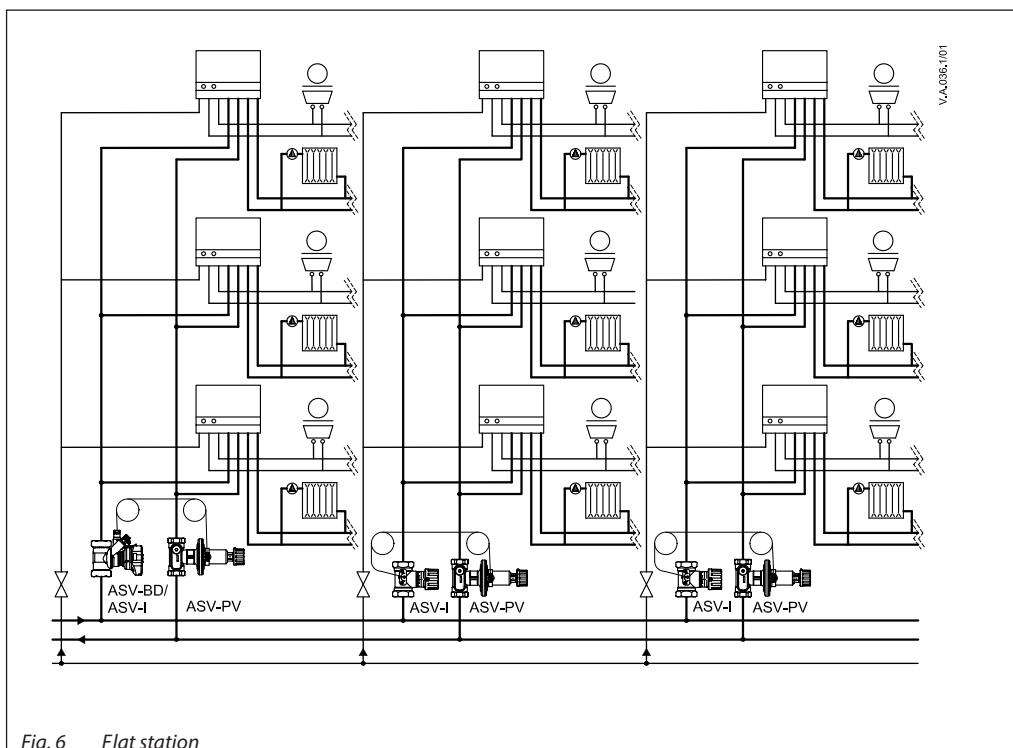

Fig. 6 Flat station

ASV automatic balancing valves can be used also in other applications. For example ASV can be used to prevent noise problems at the thermostatic radiator valves in small systems by controlling the differential pressure. ASV can be used in every application you need a small differential pressure controller, for example like small floor manifolds or flat stations. In buildings equipped with flat stations ASV valves can be used to provide secure automatic balance by the means of differential pressure control in risers/zones.

In flat stations, pressure conditions change when sanitary water heating is taking place in comparison to the situation when only heating is needed. By using ASV-PV valves the differential pressure is controlled also in those conditions.

Constant differential pressure in combination with pre-set control valves i.e. ASV-I or ASV-BD limits the flow.

Sizing

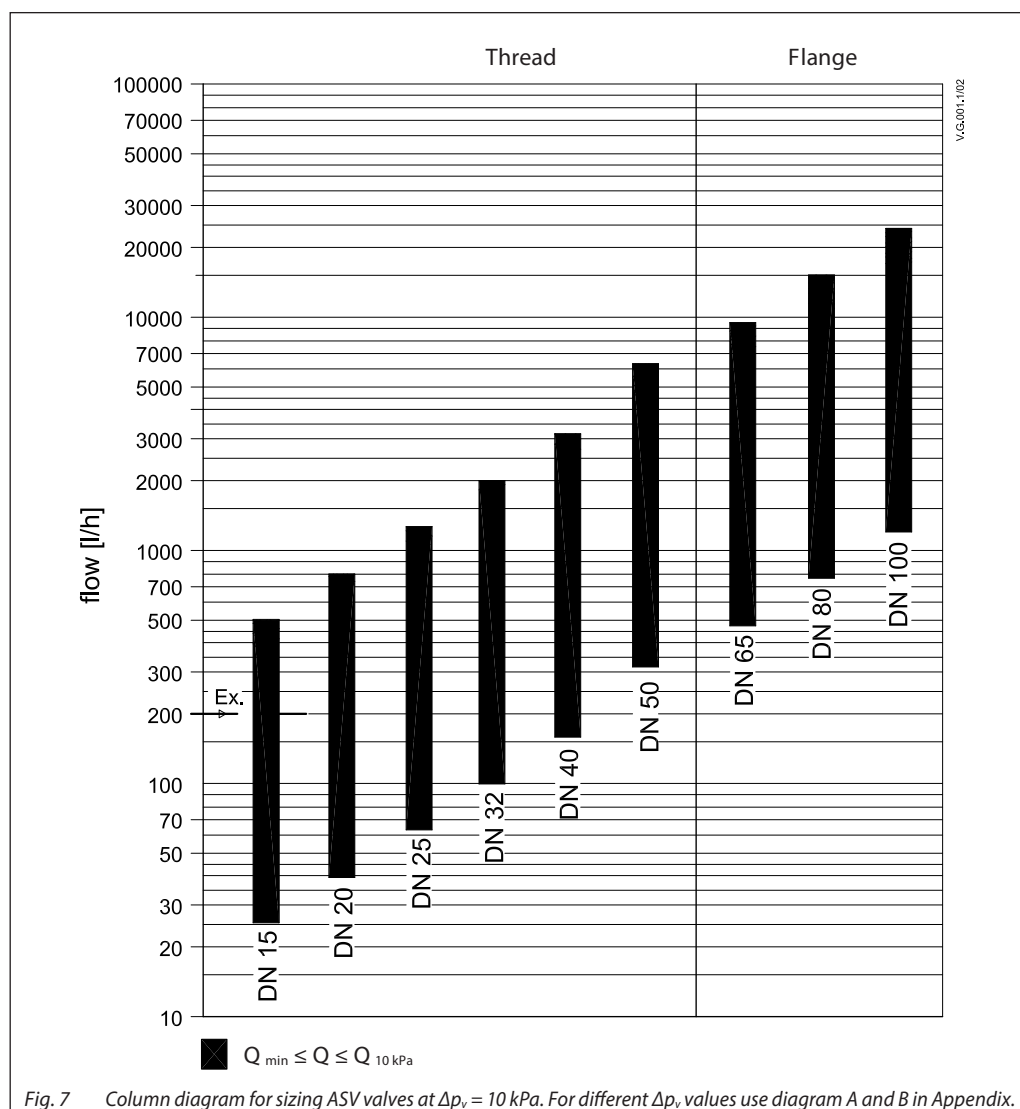

Fig. 7 Column diagram for sizing ASV valves at Δp<sub>v</sub> = 10 kPa. For different Δp<sub>v</sub> values use diagram A and B in Appendix.

We recommend to size the diameter of ASV-P/PV valves by using Fig 7. Maximum flow rates are based on 10 kPa differential pressure over the valve which allows efficient pumping and saves energy.

After ASV-P/PV valves have been sized the same dimension of partner valve ASV-BD / ASV-I / ASV-M / MSV-F2 valve should be selected.

**Example:**

Given:

Pipe flow 200 l/h, pipes DN 15

Solution:

Horizontal line intersects the column for the valve DN 15 which can therefore be selected as required size.

For detailed sizing see examples on pages 12 and 13. For different Δp<sub>v</sub> (differential pressure over the valve) see diagrams in Appendix A.

**Connection between valves size and pipe size**

K<sub>v</sub> values per particular dimension were designed to cover flow range according to VDI 2073 with water velocity of up 0.8 m/s, at differential pressure of 10 kPa over the valve. As long as the water velocity in the pipe is between 0.3 and 0.8 m/s dimension of the valve should be equal to pipe dimension.

This rule is derived out of the fact that K<sub>v</sub> values per particular dimension were designed to cover flow range according to VDI 2073 at differential pressure of 10 kPa over the valve.

Ordering

**ASV-P** balancing valve, inclusive in the box: 1,5 m impulse tube (G 1/16 A) and drain connection (G 3/4 A)  
Constant differential pressure 10 kPa ; can be upgraded to 20 or 30 kPa setting respectively

Type	DN	k <sub>vs</sub> (m³/h)	Internal thread (ISO 7/1)	Code No.	Type	External thread (ISO 228/1)	Code No.
	15	1,6	R <sub>p</sub> 1/2	<b>003L7621</b>		G 3/4 A	<b>003L7626</b>
	20	2,5	R <sub>p</sub> 3/4	<b>003L7622</b>		G 1 A	<b>003L7627</b>
	25	4,0	R <sub>p</sub> 1	<b>003L7623</b>		G 1 1/4 A	<b>003L7628</b>
	32	6,3	R <sub>p</sub> 1 1/4	<b>003L7624</b>		G 1 1/2 A	<b>003L7629</b>
	40	10	R <sub>p</sub> 1 1/2	<b>003L7625</b>		G 1 3/4 A	<b>003L7630</b>

**ASV-PV** balancing valve, inclusive in the box: 1,5 m impulse tube (G 1/16 A) and drain connection (G 3/4 A)

Type	DN	k <sub>vs</sub> (m³/h)	Connection		Δp setting range (kPa)	Code No.	
	15	1,6	Internal thread ISO 7/1	R <sub>p</sub> 1/2	5-25	<b>003L7601</b>	
	20	2,5		R <sub>p</sub> 3/4		<b>003L7602</b>	
	25	4,0		R <sub>p</sub> 1		<b>003L7603</b>	
	32	6,3		R <sub>p</sub> 1 1/4		<b>003L7604</b>	
	40	10,0		R <sub>p</sub> 1 1/2		<b>003L7605</b>	
	15	1,6		External thread ISO 228/1	R <sub>p</sub> 1/2	20-60	<b>003L7711</b>
	20	2,5			R <sub>p</sub> 3/4		<b>003L7712</b>
	25	4,0			R <sub>p</sub> 1		<b>003L7713</b>
	32	6,3			R <sub>p</sub> 1 1/4		<b>003L7714</b>
	40	10,0			R <sub>p</sub> 1 1/2		<b>003L7715</b>
	32	6,3	External thread ISO 228/1		R <sub>p</sub> 1 1/4	35-75	<b>003L7616</b>
	40	10,0			R <sub>p</sub> 1 1/2		<b>003L7617</b>
	15	1,6			G 3/4 A		5-25
	20	2,5			G 1 A	<b>003L7607</b>	
	25	4,0			G 1 1/4 A	<b>003L7608</b>	
	32	6,3		G 1 1/2 A	<b>003L7609</b>		
	40	10,0		G 1 3/4 A	<b>003L7610</b>		
	20	2,5		20-60	G 1 A	<b>003L7717</b>	
	25	4,0			G 1 1/4 A	<b>003L7718</b>	
	32	6,3			G 1 1/2 A	<b>003L7719</b>	
40	10,0	G 1 3/4 A	<b>003L7720</b>				

**ASV-PV** balancing valve, inclusive in the box:  
2,5 m impulse tube (G 1/16 A) drain connection (G 3/4 A) and adapter **003L8151**

Type	DN	k <sub>vs</sub> (m³/h)	Connection		Δp setting range (kPa)	Code No.
	50	20	External thread ISO 228/1	G 2 1/2	5-25	<b>003Z0611</b>
					20-40	<b>003Z0621</b>
					35-75	<b>003Z0631</b>
					60-100	<b>003Z0641</b>

**ASV-PV** balancing valve, inclusive in the box:  
2,5 m impulse tube (G 1/16 A), adapter ASV large **003Z0691** and **003L8151**



Type	DN	k <sub>vs</sub> (m³/h)	Connection		Δp setting range (kPa)	Code No.
	65	30	Flange EN 1092-2		20-40	<b>003Z0623</b>
	80	48				<b>003Z0624</b>
	100	76,0				<b>003Z0625</b>
	65	30			35-75	<b>003Z0633</b>
	80	48				<b>003Z0634</b>
	100	76,0				<b>003Z0635</b>
	65	30			60-100	<b>003Z0643</b>
	80	48				<b>003Z0644</b>
	100	76,0				<b>003Z0645</b>

**Ordering** (*continuous*)



**ASV-BD** shut-off valve, multifunctional partner valve (shut-off, rotating measuring station)

Type	DN	$k_{vs}$ (m <sup>3</sup> /h)	Internal thread (ISO 7/1)	Code No.
	15	3,0	R <sub>p</sub> ½	<b>003Z4041</b>
	20	6,0	R <sub>p</sub> ¾	<b>003Z4042</b>
	25	9,5	R <sub>p</sub> 1	<b>003Z4043</b>
	32	18	R <sub>p</sub> 1¼	<b>003Z4044</b>
	40	26	R <sub>p</sub> 1½	<b>003Z4045</b>
	50	40	R <sub>p</sub> 2	<b>003Z4046</b>

**ASV-M** shut-off valve, without test plugs











Type	DN	$k_{vs}$ (m <sup>3</sup> /h)	Internal thread (ISO 7/1)	Code No.	Type	External thread (ISO 228/1)	Code No.
	15	1,6	R <sub>p</sub> ½	<b>003L7691</b>		G ¾ A	<b>003L7696</b>
	20	2,5	R <sub>p</sub> ¾	<b>003L7692</b>		G 1 A	<b>003L7697</b>
	25	4,0	R <sub>p</sub> 1	<b>003L7693</b>		G 1¼ A	<b>003L7698</b>
	32	6,3	R <sub>p</sub> 1¼	<b>003L7694</b>		G 1½ A	<b>003L7699</b>
	40	10	R <sub>p</sub> 1½	<b>003L7695</b>		G 1¾ A	<b>003L7700</b>
	50	16				G 2¼ A	<b>003L7702</b>

**ASV-I** adjustment valve, inclusive two test plugs

Type	DN	$k_{vs}$ (m <sup>3</sup> /h)	Internal thread (ISO 7/1)	Code No.	Type	External thread (ISO 228/1)	Code No.
	15	1,6	R <sub>p</sub> ½	<b>003L7641</b>		G ¾ A	<b>003L7646</b>
	20	2,5	R <sub>p</sub> ¾	<b>003L7642</b>		G 1 A	<b>003L7647</b>
	25	4,0	R <sub>p</sub> 1	<b>003L7643</b>		G 1¼ A	<b>003L7648</b>
	32	6,3	R <sub>p</sub> 1¼	<b>003L7644</b>		G 1½ A	<b>003L7649</b>
	40	10	R <sub>p</sub> 1½	<b>003L7645</b>		G 1¾ A	<b>003L7650</b>
	50	16				G 2¼ A	<b>003L7652</b>

Ordering (continuous)

Accessories and spare parts

Description	Comments/connection	Code No.
Shut-off knob for ASV-I (black) 	DN 15	003L8155
	DN 20	003L8156
	DN 25	003L8157
	DN 32/DN 40/DN 50	003L8158
Shut-off knob for ASV-M (black) 	DN 15	003L8146
	DN 20	003L8147
	DN 25	003L8148
	DN 32/DN 40/DN 50	003L8149
Differential pressure measuring connector 	For drain connection	003L8143
Drain connection 	For ASV-PV (DN 15-50)	003L8141
Two test plugs and one locking plate 	For ASV-I and ASV-M, rectus type (DN 15-40)	003L8145
3 mm test plugs, 2 pcs	For ASV-BD <sup>4)</sup>	003Z4662
Operating handle	For ASV-BD <sup>4)</sup>	003Z4652
Impulse tube, with O-rings 	1.5 m	003L8152
	2.5 m	003Z0690
	5 m	003L8153
Plastic impulse tube with connectors and adapters (industry pack)	10 pcs order quantity	003Z0689
Adapter large ASV <sup>1)</sup> 	G ¼-R ¼; G ¼	003Z0691
Plug for connecting impulse tube <sup>2)</sup> 	G ¼-R ¼	003L8151
Plug for connecting impulse tube on other valves (US standard) 	G ¼-9/16-20 UNF-2B	003L8176
O-ring for impulse tube <sup>3)</sup>	2,90 × 1,78	003L8175
Plug for impulse tube connection ASV-I/M <sup>3)</sup>	G ¼ A	003L8174
ASV-P 20 kPa spring (yellow) 	DN 15	003L8182
	DN 20	003L8183
	DN 25	003L8184
	DN 32/DN 40	003L8185
ASV-P 30 kPa spring (green)	DN 15	003L8192
	DN 20	003L8193
	DN 25	003L8194
	DN 32/DN 40	003L8195

<sup>1)</sup> Recommended for use with MSV-F2, connected to measuring hole, it allows connection of impulse tube from ASV while retaining measurement functionality.

<sup>2)</sup> Recommended for use with MSV-F2, connected to measuring hole. Can also be used for connecting impulse tube directly on the pipe.

<sup>3)</sup> Set of 10 pieces.

<sup>4)</sup> for whole range of ASV-BD accessories please refer to Leno™ MSV-BD datasheet.

Technical data

Type		ASV-I/M/P/PV		ASV-BD
Nominal diameter	DN	15-40	50-100	15-50
Max. pressure	bar	16 (PN 16)		20
Test pressure		25		30
Differential pressure over the valve	kPa	10-150 <sup>1)</sup>	10-250 <sup>2)</sup>	10-250
Temperature	°C	-20 ... 120	-10 ... 120	-20 ... 120
<b>Material of parts in contact with water</b>				
Valve body	Brass	Grey cast iron EN-GJL-250 (GG 25)	DZR brass	
Cone (ASV-P/PV)	DZR brass	Stainless steel		
Ball	-			Brass / chromium plated
Membrane / O-rings	EPDM			
Spring	Stainless steel			-

<sup>1)</sup> Please note that the maximum admissible differential pressure across the valve 150 kPa should also not be exceeded at partial load.

<sup>2)</sup> Please note that the maximum admissible differential pressure across the valve 250 kPa should also not be exceeded at partial load.



**Design**

1. Shut-off knob
2. Shut-off spindle
3. O-ring
4. Reference spring
5. Impulse tube connection
6. Diaphragm element
7. Control diaphragm
8. Pressure-relieved valve cone
9. Valve body
10. Seat

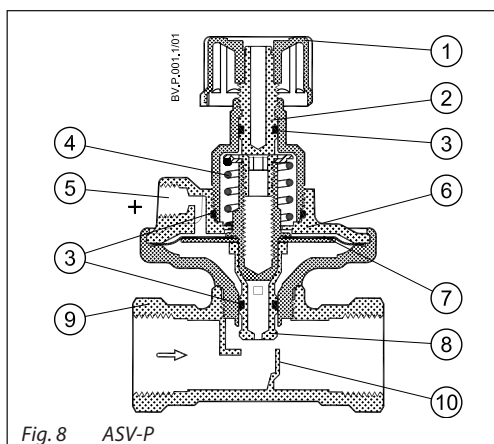

Fig. 8 ASV-P

The ASV-P is designed to maintain constant differential pressure across a riser. Via an internal connection and together with the reference spring, pressure in the return pipe acts on the underside of the control diaphragm (7) while via an impulse tube (5), pressure in the flow pipe acts on the top of the diaphragm. In this way the balancing valve maintains a fixed differential pressure of 10 kPa.

The setting can be increased to 20 or 30 kPa by spring replacement. Spring can be replaced under pressure. The ability to increase the setting is especially useful in case of trouble shooting. It gives insurance that design flow can be achieved even if calculation doesn't match actual installation.

1. Shut-off knob
2. Differential pressure setting spindle
3. O-ring
4. Reference spring
5. Impulse tube connection
6. Diaphragm element
7. Control diaphragm
8. Pressure-relieved valve cone
9. Valve body
10. Seat

n	5-25	20-60	35-75
(turns)	(kPa)	(kPa)	(kPa) <sup>1)</sup>
0	25	60	75
1	24	58	73
2	23	56	71
3	22	54	69
4	21	52	67
5	20	50	65
6	19	48	63
7	18	46	61
8	17	44	59
9	16	42	57
10	15	40	55
11	14	38	53
12	13	36	51
13	12	34	49
14	11	32	47
15	10	30	45
16	9	28	43
17	8	26	41
18	7	24	39
19	6	22	37
20	5	20	35

<sup>1)</sup> DN 32/40 only

Fig. 9 ASV-PV (DN 15-40)

DN	15	2.5
	20	3
	25	4
	32	5
	40	5

**Factory presetting**

Δp setting range (kPa)	kPa
5 - 25	10
20 - 60	30
35 - 75	60

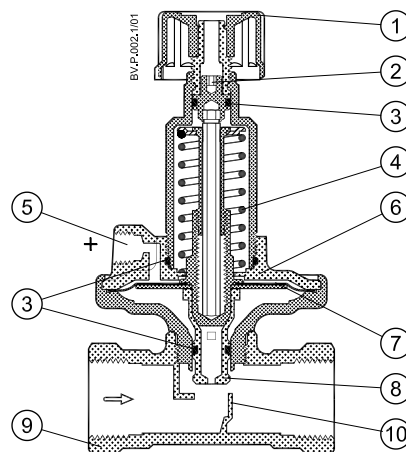

**Design** (continuous)

1. Shut-off knob
2. Differential pressure setting spindle
3. O-ring
4. Reference spring
5. Impulse tube connection
6. Diaphragm element
7. Control diaphragm
8. Pressure-relieved valve cone
9. Valve body
10. Seat

n (turns)	5-25 (kPa)	20-40 (kPa)	35-75 (kPa)	60-100 (kPa)
0	25	40	75	100
1	24	39	73	98
2	23	38	71	96
3	22	37	69	94
4	21	36	67	92
5	20	35	65	90
6	19	34	63	88
7	18	33	61	86
8	17	32	59	84
9	16	31	57	82
10	15	30	55	80
11	14	29	53	78
12	13	28	51	76
13	12	27	49	74
14	11	26	47	72
15	10	25	45	70
16	9	24	43	68
17	8	23	41	66
18	7	22	39	64
19	6	21	37	62
20	5	20	35	60

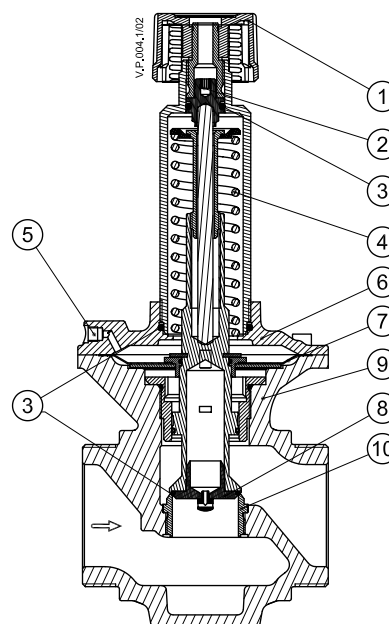

**Factory presetting**

$\Delta p$ setting range (kPa)	kPa
5-25	10
20-40	30
35-75	60
60-100	80

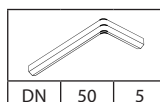

Fig. 10 ASV-PV (DN 50)

ASV-PV is designed to maintain a constant set differential pressure. Via an internal connection and together with the reference spring (4), pressure in the return pipe acts on the underside of the control diaphragm (7) while via an impulse tube (5), pressure in the flow pipe acts on the top of the diaphragm. In this way the balancing valve maintains adjusted differential pressure.

The ASV-PV valves are sold in four different  $\Delta p$  setting ranges. The valves are factory-set to a defined value as described on Factory presetting table on Fig. 9, 10 and 11.

Use the following procedure to set the desired differential pressure:  
 the setting on ASV-PV can be changed by turning the setting spindle (2).  
 Turning the spindle clockwise increases the setting; turning it counter clockwise reduces the setting.

If the setting is not known, turn the spindle fully clockwise. With this the setting on ASV-PV is at maximum value within setting range. Now turn the spindle a number of times (n) as described in Fig. 9, 10 or 11 until the required differential pressure setting is obtained.

Design (continuous)

- 1. Shut-off knob
- 2. Differential pressure setting spindle
- 3. O-ring
- 4. Flat gasket
- 5. Reference spring
- 6. Impulse tube connection
- 7. Diaphragm element
- 8. Control diaphragm
- 9. Pressure-relieved valve cone
- 10. Valve body
- 11. Seat
- 12. Measuring holes-plugged
- 13. Air-vent

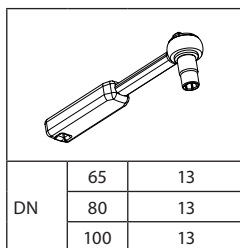

DN	65	13
	80	13
	100	13

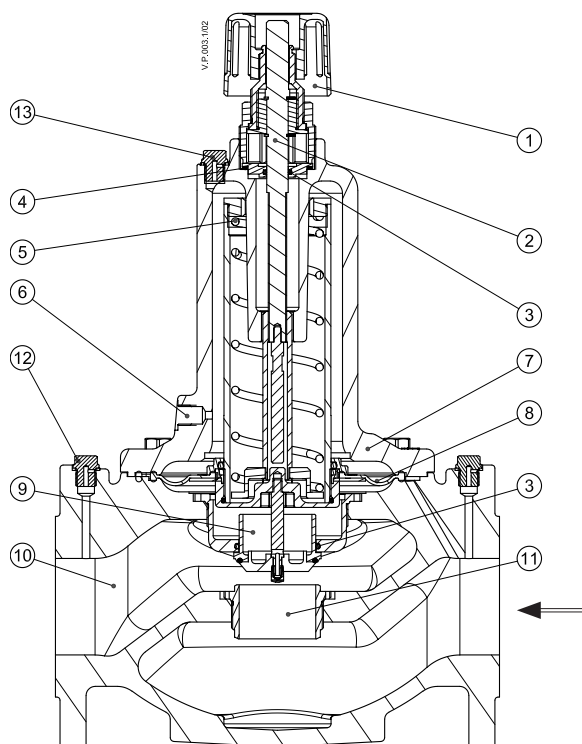

Factory presetting

$\Delta p$ setting range (kPa)	kPa
20-40	30
35-75	60
60-100	80

n (turns)	20-40 (kPa)	35-75 (kPa)	60-100 (kPa)
0	40	75	100
1	39	74	99
2	38	73	98
3	37	72	97
4	36	71	96
5	35	70	95
6	34	69	94
7	33	68	93
8	32	67	92
9	31	66	91
10	30	65	90
11	29	64	89
12	28	63	88
13	27	62	87
14	26	61	86
15	25	60	85
16	24	59	84
17	23	58	83
18	22	57	82
19	21	56	81
20	20	55	80

n (turns)	20-40 (kPa)	35-75 (kPa)	60-100 (kPa)
21		54	79
22		53	78
23		52	77
24		51	76
25		50	75
26		49	74
27		48	73
28		47	72
29		46	71
30		45	70
31		44	69
32		43	68
33		42	67
34		41	66
35		40	65
36		39	64
37		38	63
38		37	62
39		36	61
40		35	60

Fig. 11 ASV-PV (DN 65-100)

**Design** (continuous)

1. Handle with setting scale
2. Spindle head
3. Rotation lock
4. Test plug
5. Valve top
6. Spindle
7. Impulse tube connection
8. Closing bush
9. Hose connection
10. Rotating measuring station
11. Throttle bush
12. Supporting screw
13. Ball seat
14. Ball
15. Valve body

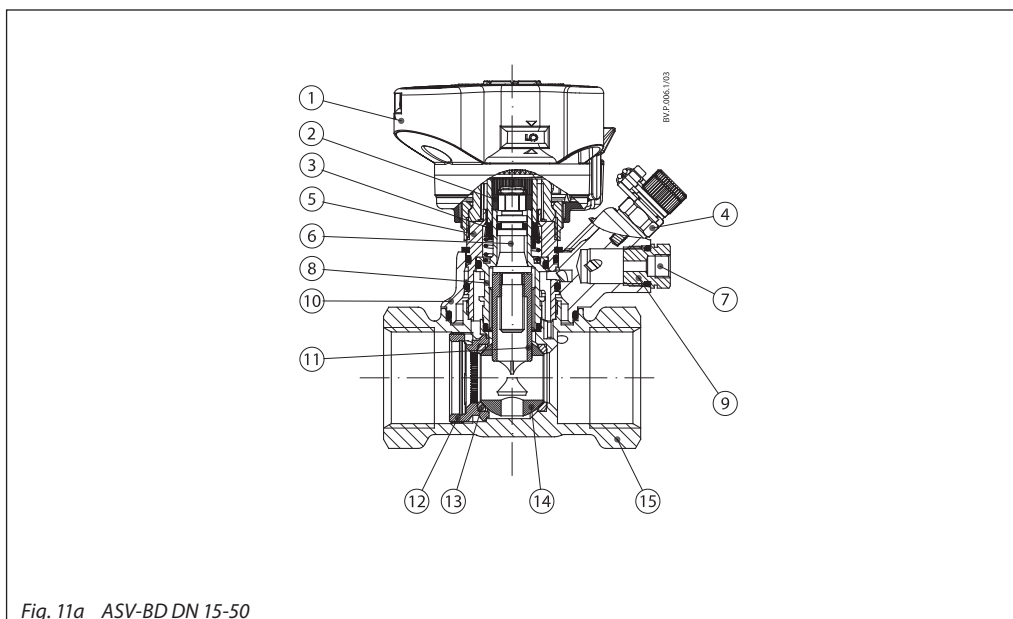

Fig. 11a ASV-BD DN 15-50

**Partner valves** ASV-BD/I/M are to be used together with the automatic balancing valves ASV-PV/P to control differential pressure in the risers.

ASV-BD is a combined presetting and shut off valve with a range of unique features:

- high kv values for small pressure losses
- partner valve position inside or outside control loop (see page 2 for details), chooseable even after the valve is already installed and under pressure.
- numeric presetting scale, visible from multiple angles
- easy locking of presetting
- rotating measuring station with built-in test plugs for 3 mm needles
- drain function via drain connection accessory (Code No. **003Z4096** or **003Z4097**)
- shut-off function separated from presetting,
- removable hand wheel for easy mounting,
- open-closed colour indicator.

**Impulse tube connection**

The impulse line must be connected to impulse tube connection piece (15). In working position, one of test plugs needs to be open while other closed. There are two possible configurations, with partner valve inside or outside control loop. It can be chosen by impulse tube connection side:

- Partner valve **outside** controlled loop: opened outlet test plug (**blue** marking). ASV-BD needs to be set to max setting (fully open). Flow verification is possible.
- Partner valve **inside** controlled loop: opened inlet test plug (red marking). Flow limitation with flow verification is possible.

**Note:**

**Default position** is opened inlet test plug (blue marking).

**Flow limitation**

Use the following procedure:

1. When valve is open the lock is released. Allen key can also be used.
2. The handle pops up and the required flow setting may be set.
4. Lock the setting by pressing the handle until click.
5. If needed, flow can be measured using Danfoss PFM or other brand of measuring instrument.

**Flow verification (in case ASV-BD is used outside controlled loop)**

Use the following procedure:

1. ASV-BD setting is at maximum value.
2. Flow can be measured using PFM 4000 or other brand of measuring instrument.
3. If pressure drop across the valve is too low for reliable flow measurement, ASV-BD needs to be set to lower setting to achieve high enough pressure drop across the valve.
4. After flow measurement, return the setting to maximum value and lock it by pressing the handle until click.

**Draining**

Use the following procedure to drain:

1. Close opened test plug.
2. Remove the impulse tube.
3. Dismount the hose connection.
4. Fit drain connection accessory (Code No. **003Z4096** or **003Z4097**).
5. Blue test plug opens the outlet while red test plug opens the inlet. Make sure not to use more than max. 3 turns. Drain connection and test plugs can rotate to any position.

**Note:**

**when draining, always keep same or higher static pressure on upper part of ASV-P/PV membrane. Therefore, always drain from return pipe first and remove impulse tube only after return pipe is empty. If draining is done from flow pipe first, membrane can be damaged.**

Design (continuous)

1. Shut-off knob
2. Shut-off spindle
3. Setting spindle
4. Scale disc
5. O-rings
6. Valve cone
7. Seat
8. Valve body

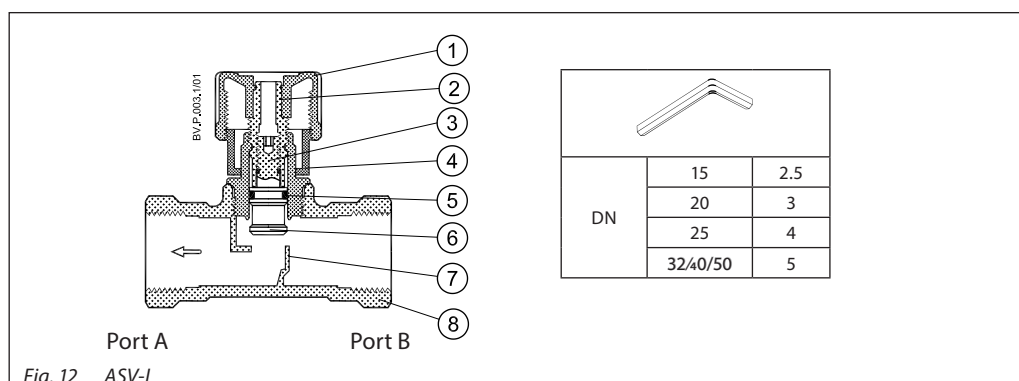

Fig. 12 ASV-I

ASV-I incorporates a double cone able to give maximum stroke limitation, thus achieving flow limitation. It also incorporates shut off function. ASV-I is equipped with the plugs for the flow measurement and a connection for the ASV-P/ASV-PV impulse tube.

Use the following procedure to limit the flow: turn the valve knob fully counter clockwise to open the valve. The mark on the knob will now be opposite »0« on the scale. Turn the valve knob clockwise to the required setting (e.g. for setting 2.2 the knob must be rotated two full turns and then forward to »2« on the scale. Hold the knob to keep the setting (e.g. 2.2) and using a

hexagon socket key turn the spindle fully counter clockwise (until a stop can be felt). Turn the valve knob fully counter clockwise so that the mark on the knob is opposite »0« on the scale.

The valve is now open as many turns from the closed position (2.2) as indicated by the conversion from required flow. To annul the setting, turn the hexagon socket key fully clockwise (until a stop can be felt).

Remember, at the same time the knob must be held on its »0« setting.

To read presetting valve has to be closed.

1. Shut-off knob
2. Shut-off spindle
3. O-rings
4. Valve cone
5. Seat
6. Valve body

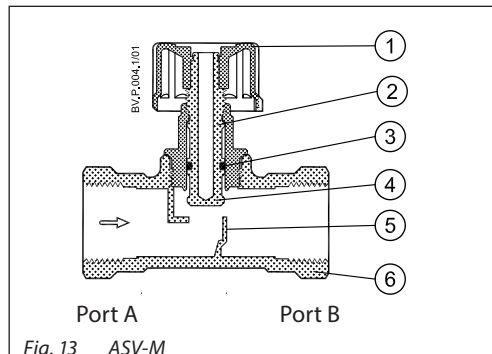
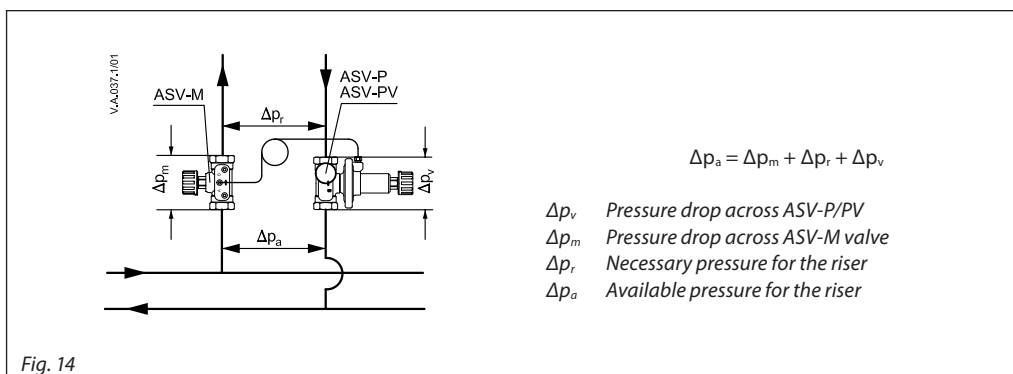

Fig. 13 ASV-M

ASV-M is designed to shut-off the pipe flow. ASV-M has a connection for an impulse tube to ASV-P/ASV-PV. It can be equipped with plugs for flow measuring (which are sold separately as accessories).

Sizing-design examples



$$\Delta p_a = \Delta p_m + \Delta p_r + \Delta p_v$$

- $\Delta p_v$  Pressure drop across ASV-P/PV
- $\Delta p_m$  Pressure drop across ASV-M valve
- $\Delta p_r$  Necessary pressure for the riser
- $\Delta p_a$  Available pressure for the riser

Fig. 14

1. Example

**Given:**  
 Radiator system with thermostatic radiator valves with pre-setting function.  
 Desired flow for the riser (Q):..... 1,500 l/h  
 Minimal available pressure for that riser ( $\Delta p_a$ ) .....70 kPa  
 Estimated pressure drop over the riser at the desired flow ( $\Delta p_r$ ) .....20 kPa

**Wanted:**  
 - Valve type  
 - Valve size  
 Since radiator valves has pre-setting function ASV-M is selected.  
 Since desired pressure drop over the riser is 20 kPa ASV-PV is selected.  
 ASV-PV should control 20 kPa pressure over the riser that means that 50 kPa out of 70 will be disposed over two valves.

$$\Delta p_v + \Delta p_m = \Delta p_a - \Delta p_r = 70 - 20 = 50 \text{ kPa}$$

We presume that dimension DN 25 is the right dimension for this example (please mind that both valves should be of the same dimension). As ASV-M DN 25 is to be fully open pressure drop is calculated by following equation:

$$\Delta p_m = \left(\frac{Q}{Kv}\right)^2 = \left(\frac{1.5}{4.0}\right)^2 = 0.14 \text{ bar} = 14 \text{ kPa}$$

or by reading from diagram in **Appendix A, fig. E** as follows:  
 Draw horizontal line from 1.5 m<sup>3</sup>/h (~1,500 l/h) trough the line that depicts dimension DN 25. From the intersection draw vertical line to read that pressure drop is 14 kPa.  
 Pressure drop over ASV-PV valve is therefore:

$$\Delta p_v = (\Delta p_a - \Delta p_r) - \Delta p_m = 50 \text{ kPa} - 14 \text{ kPa} = 36 \text{ kPa}$$

as can be read from diagram in **Appendix A, Fig. A.**

2. Example

Correcting the flow with the differential pressure setting.

**Given:**  
 Measured flow for the riser  $Q_1$ ..... 1,500 l/h  
 ASV-PV valve's setting  $\Delta p_r$  ..... 20 kPa

**Wanted:**  
 New valves' setting to increase the flow for 10 %,  $Q_2 = 1650 \text{ l/h}$ .

**Setting on the ASV-PV valve:**  
 When needed setting of the control pressure can be adjusted to particular value (ASV-PV from 5 to 25 kPa or 20 to 40 kPa).  
 With increasing/decreasing the setting it is possible to adjust flow trough the riser, terminal or similar. (100 % increase of control pressure will increase the flow for 41 %)

$$p_2 = p_1 \times \left(\frac{Q_2}{Q_1}\right)^2 = 0.20 \times \left(\frac{1650}{1500}\right)^2 = 24 \text{ kPa}$$

If we increase the setting to 24 kPa flow will be increased to 10 % to 1,650 l/h.

Sizing-design examples  
(continuous)

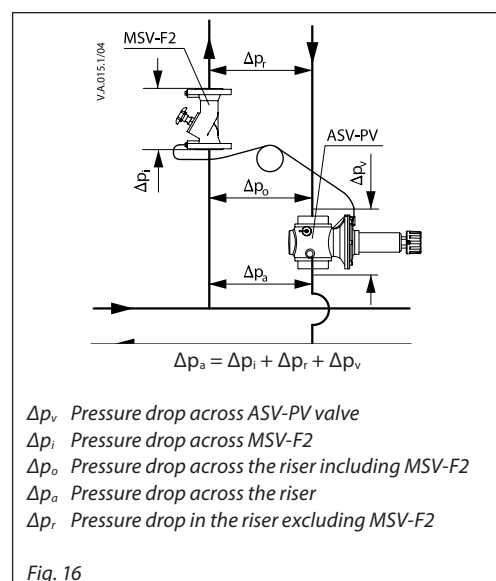
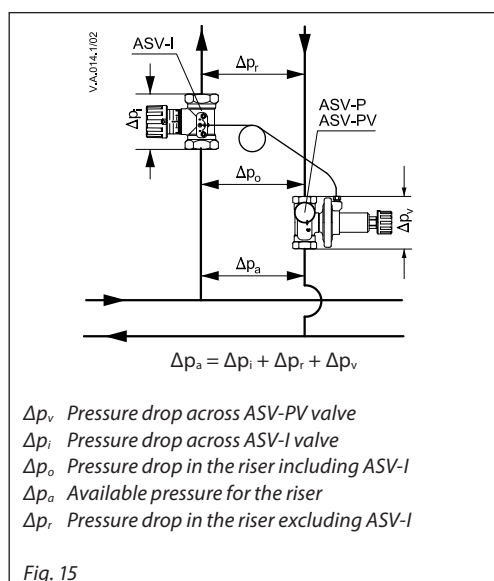

**3. Example**  
Limiting the flow with ASV-I valve

Given:  
 Desired flow for the branch (Q): ..... 880 l/h  
 ASV-PV and ASV-I (DN 25)  
 Setting on the ASV-PV valve ( $\Delta p_o$ ) ..... 10 kPa  
 Estimated pressure drop over the riser at desired flow ( $\Delta p_r$ ) ..... 4 kPa

Required:  
 Setting of the ASV-I valve to achieve desired flow

Solution:  
 When needed setting of the ASV-I can be adjusted to perform flow limitation function. ASV-I namely is inside the control loop of the pressure controller therefore adjusting ASV-I would result in adjusting flow limitation. (General rule is that 100 % increase of  $k_v$  value will increase the flow for 100 %)

$$k_v = \frac{Q}{\sqrt{\Delta p_v}} = \frac{0.880}{\sqrt{0.06}} = 3.6 \text{ m}^3/\text{h}$$

The result can be read as well from diagram in **Appendix A, Fig. D.**

At desired flow pressure drop over the entire branch is 4 kPa. Without using ASV-I flow through the branch at fully open control valve will be 58 % higher thus causing overflow (4 kPa allow 880 l/h, while 10 kPa allow 1390 l/h). With adjusting the ASV-I DN 25 on value 90 %  $k_v$  value (3.6 m<sup>3</sup>/h) we will limit the flow to 880 l/h as desired.

This value is obtained by following calculation:

$$\Delta p_i = \Delta p_o - \Delta p_r = 10 - 4 = 6 \text{ kPa.}$$

**4. Example**  
Flat station application

Given:  
 No. of flat stations connected to one riser ..... 5  
 Heating power of each station ..... 15 kW  
 Sanitary water heating on each station ..... 35 kW  
 Simultaneous factor (source TU Dresden) ..... 0.407  
 Desired flow for branch (Q): ..... 6,400 l/h  
 Minimal available pressure for that riser ( $\Delta p_a$ ) ..... 80 kPa  
 Estimated pressure drop over the riser at the desired flow ( $\Delta p_o$ ) ..... 50 kPa

Wanted:  
 - Valve type  
 - Valve size.

For maximum flow calculation in the riser, simultaneous factor is used since sanitary water consumption is temporary occurrence and is not used simultaneously in all apartments-flats. Since water flow through heat exchanger while heating sanitary water is not controlled, maximum flow needs to be limited as well.

Since desired pressure drop over the riser is 50 kPa ASV-PV with range between 0,35 and 0,75 bar (35 and 75 kPa) is selected.

Since 80 kPa is available for the riser,  $\Delta p_r$  shall be 30 kPa.

$$\Delta p_v = \Delta p_a - \Delta p_o = 80 - 50 = 30 \text{ kPa}$$

$$k_v = \frac{Q}{\sqrt{\Delta p_v}} = \frac{6.4}{\sqrt{0.3}} = 11.7 \text{ m}^3/\text{h}$$

For 6.400 l/h DN 50 size valve is selected as calculated above or by reading from diagram in **Appendix A, fig. B.** If needed, to limit the flow through the riser the valve ASV-I or MSV-F2 to be used.

**Measurement of flow and differential pressure**

ASV-BD (needle type) and ASV-I (rectus type) are equipped with two test plugs so that the differential pressure across the valve can be measured using Danfoss measuring equipment or any other measuring device. Using the pressure drop graph for ASV-BD (Appendix A, fig C) or ASV-I (Appendix A, fig D), the actual differential pressure across a valve can be converted to actual flow.

For rectus type test plugs: when the measuring equipment quick couplings are connected, the test plugs can be opened by giving them a half-turn counter clockwise with an 8 mm open-ended spanner. After measurement, the plugs must be closed again by turning them back clockwise and disconnecting the quick-couplings.

**Note:** When measuring sized flow, all radiator valves must be fully open (nominal flow).

**Measurement of differential pressure ( $\Delta p$ ) across riser.**

Fit a measuring connector (Danfoss code no. **003L8143**) on the ASV-P/PV balancing valve drain connection (DN 15-50) or threaded connection closer to the terminal unit (TU). Measurements must be taken between the test plug at ASV-BD/ASV-I/ASV-M/MSV-F2 valve port B and the measuring connector on the ASV-P/PV.

**Installation**

ASV-P, ASV-PV must be installed in the return pipe with flow in the direction of the arrow on the valve body. Partner valves (ASV-M/I/BD, MSV--F2) must be installed in the flow pipe, with flow in the direction of the arrow on the valve body. The impulse tube must be installed between partner valve and ASV-P/PV. The impulse tube must be flushed through before installation. ASV-PV and ASV-I/BD must in addition be installed as determined by installation conditions.

**Pressure testing**

Max. test pressure ..... 25 bar

When pressure testing the system you must secure that both sides of the membrane have the same static pressure to prevent damage of the pressure controller. That means the impulse tube must be connected and any needle valves must be open.

If ASV-P/PV DN 15-50 is installed in combination with ASV-M both valves must be open or closed (both valves must be in the same position!). If ASV-P/PV DN 15-50 is installed in combination with ASV-I /ASV-BD both valves must be open. During this operation (closing or opening the valves) please make sure that there is never lower pressure on upper side of the membrane to prevent damaging it .

**Starting**

During system start – opening the shut-off on ASV-PV and partner valve-please secure that there is the same static pressure on both sides or higher pressure on upper side of the membrane. If filling is done by opening ASV-PV and partner valve, please make sure there is a pressure on the upper side of the membrane by opening partner valve first before ASV-PV is opened.



Dimensions

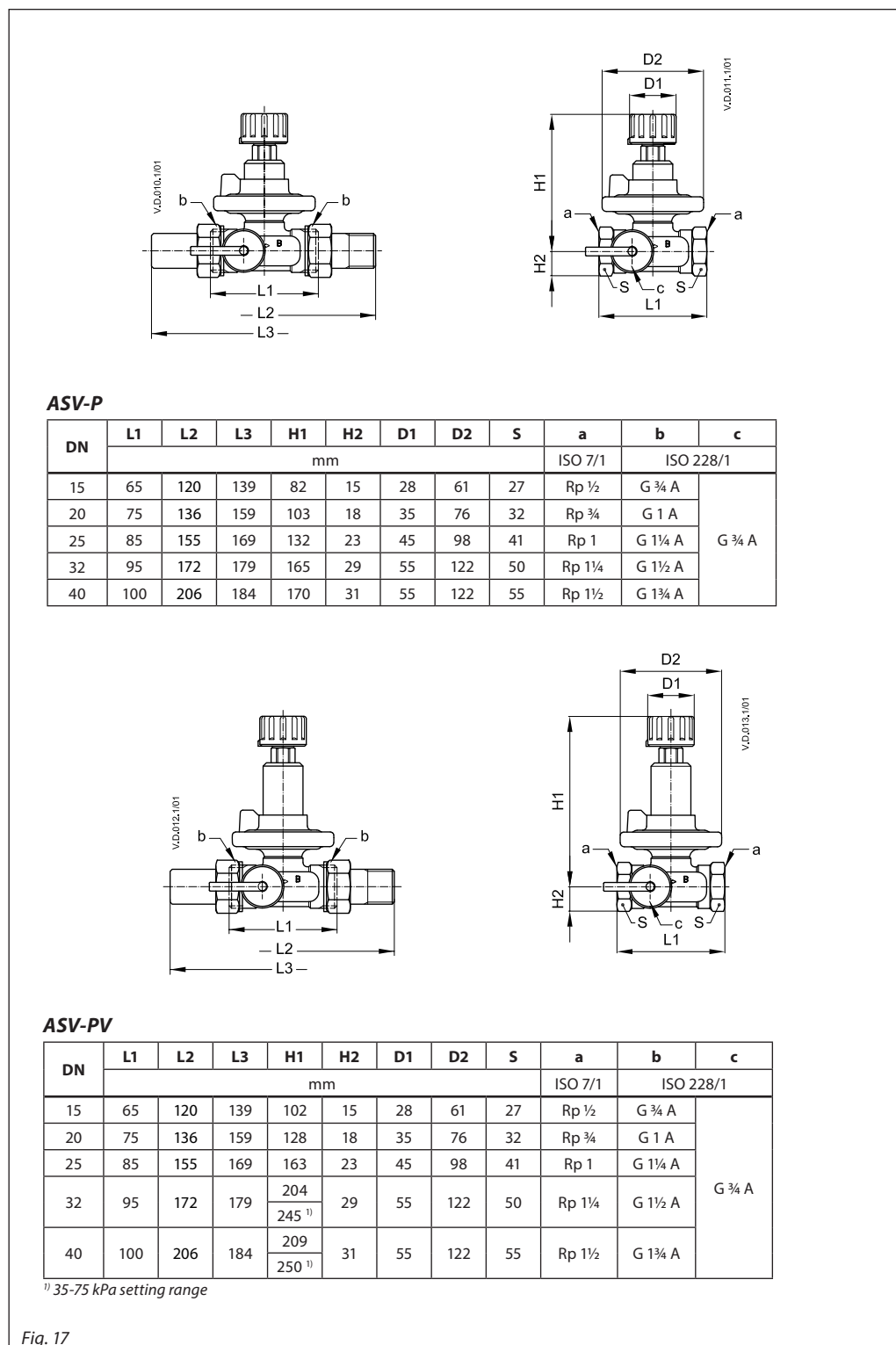

Dimensions  
(continuous)

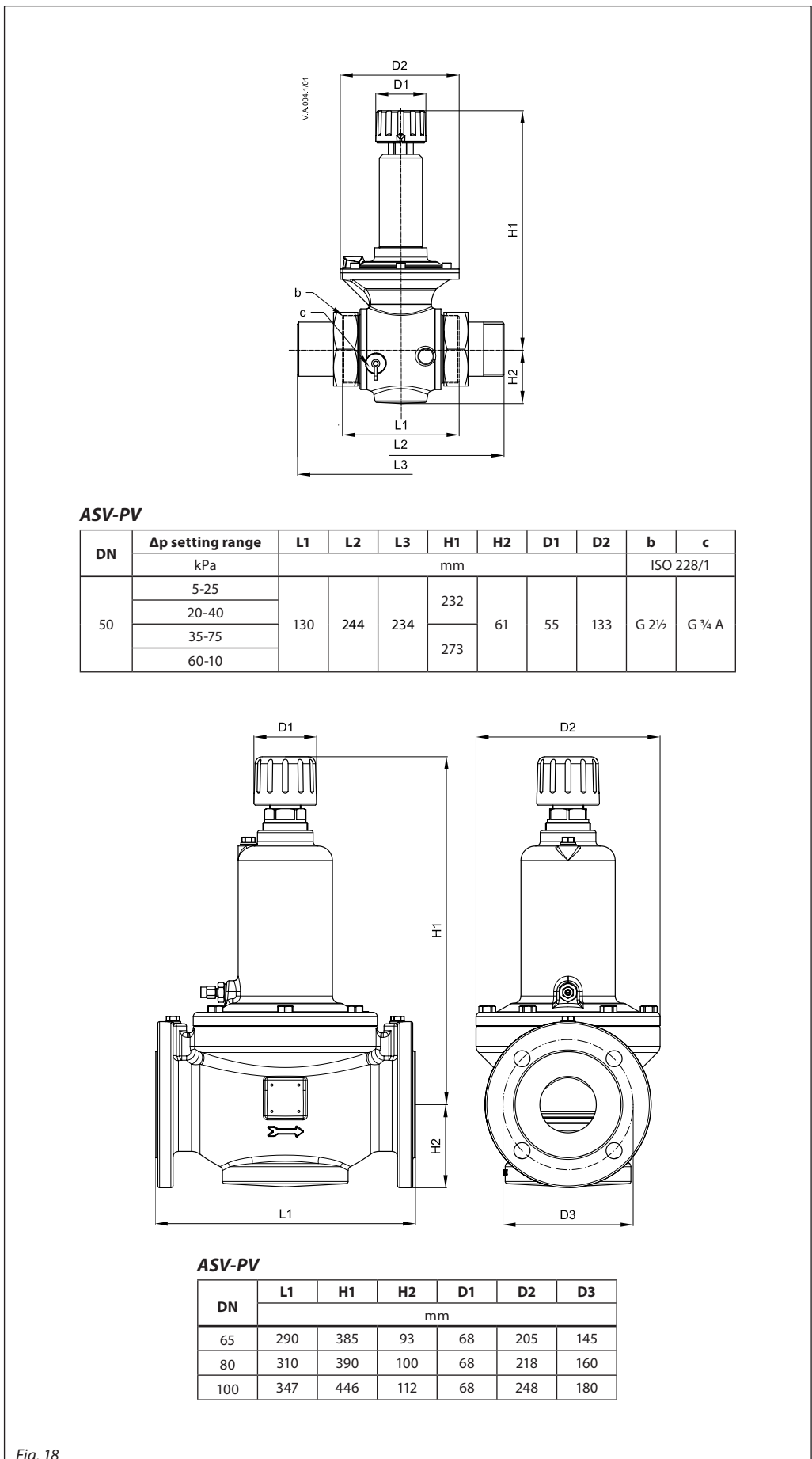
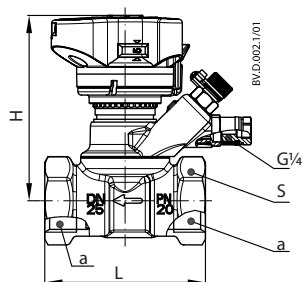

Fig. 18

Dimensions  
(continuous)



ASV-BD

DN	L	H	S	a
	mm			ISO 228/1
15	65	92	27	G ½
20	75	95	32	G ¾
25	85	98	41	G 1
32	95	121	50	G 1¼
40	100	125	55	G 1½
50	130	129	67	G 2

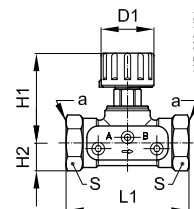
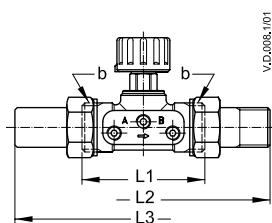

ASV-M

DN	L1	L2	L3	H1	H2	D1	S	a	b
	mm							ISO 7/1	ISO 228/1
15	65	120	139	48	15	28	27	Rp ½	G ¾ A
20	75	136	159	60	18	35	32	Rp ¾	G 1 A
25	85	155	169	75	23	45	41	Rp 1	G 1¼ A
32	95	172	179	95	29	55	50	Rp 1¼	G 1½ A
40	100	206	184	100	31	55	55	Rp 1½	G 1¾ A
50	130	246	214	106	38	55	67	-	G 2¼ A

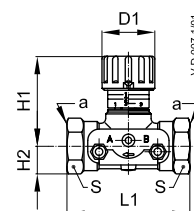
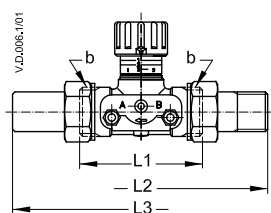

ASV-I

DN	L1	L2	L3	H1	H2	D1	S	a	b
	mm							ISO 7/1	ISO 228/1
15	65	120	139	48	15	28	27	Rp ½	G ¾ A
20	75	136	159	60	18	35	32	Rp ¾	G 1 A
25	85	155	169	75	23	45	41	Rp 1	G 1¼ A
32	95	172	179	95	29	55	50	Rp 1¼	G 1½ A
40	100	206	184	100	31	55	55	Rp 1½	G 1¾ A
50	130	246	214	106	38	55	67	-	G 2¼ A

Fig. 19

Appendix A-Sizing diagram

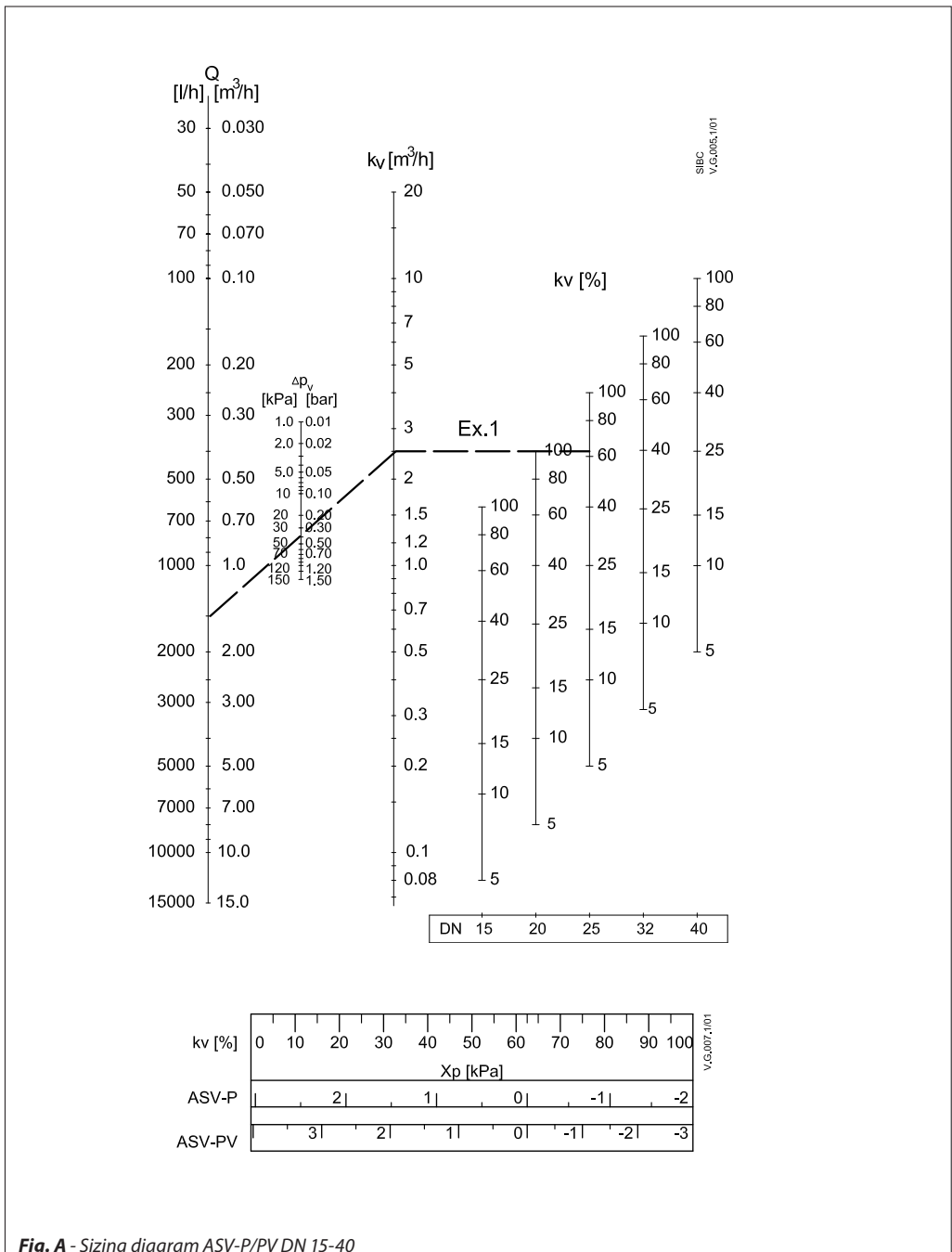

Appendix A-Sizing diagram

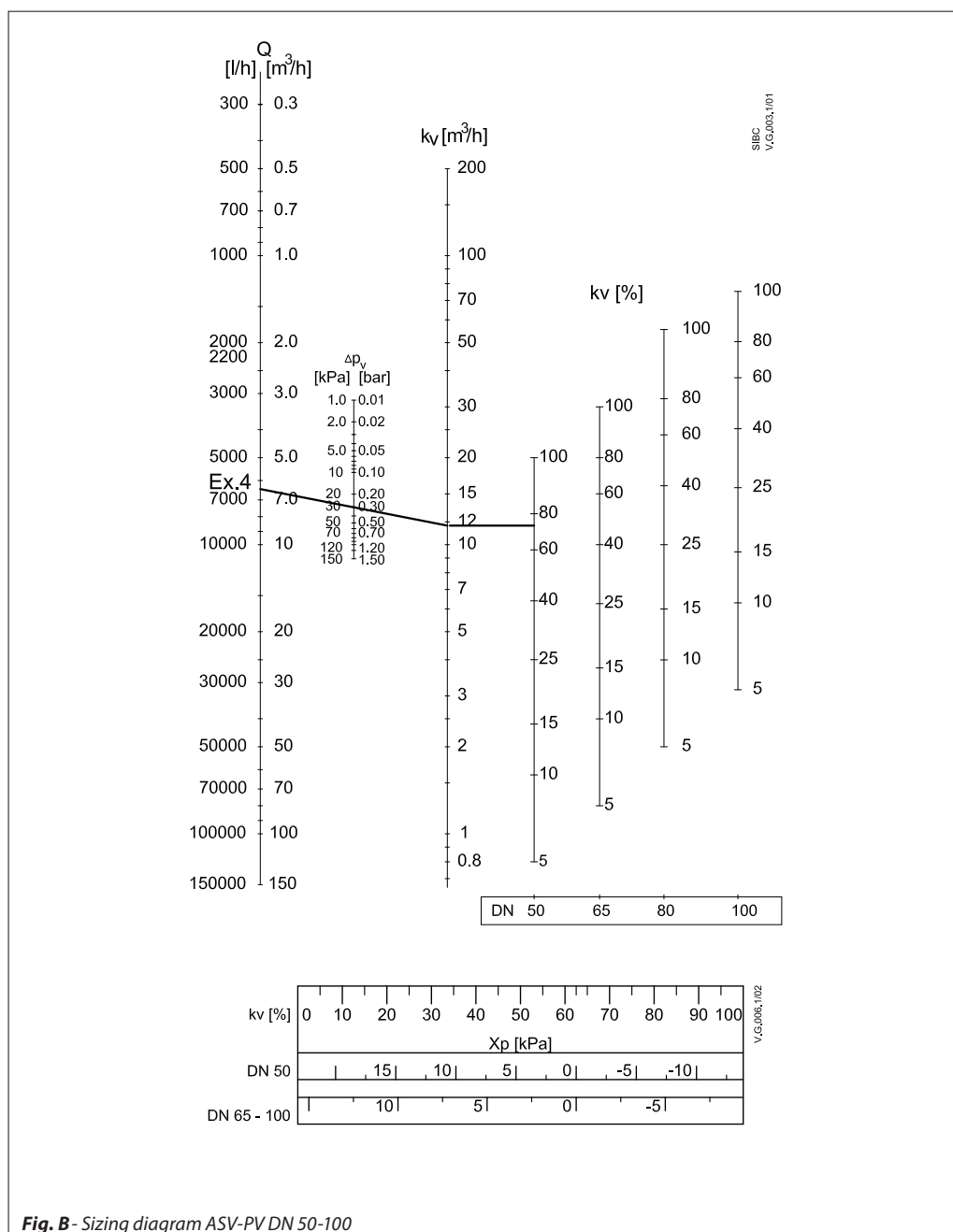

Fig. B - Sizing diagram ASV-PV DN 50-100

Appendix A-Sizing diagram

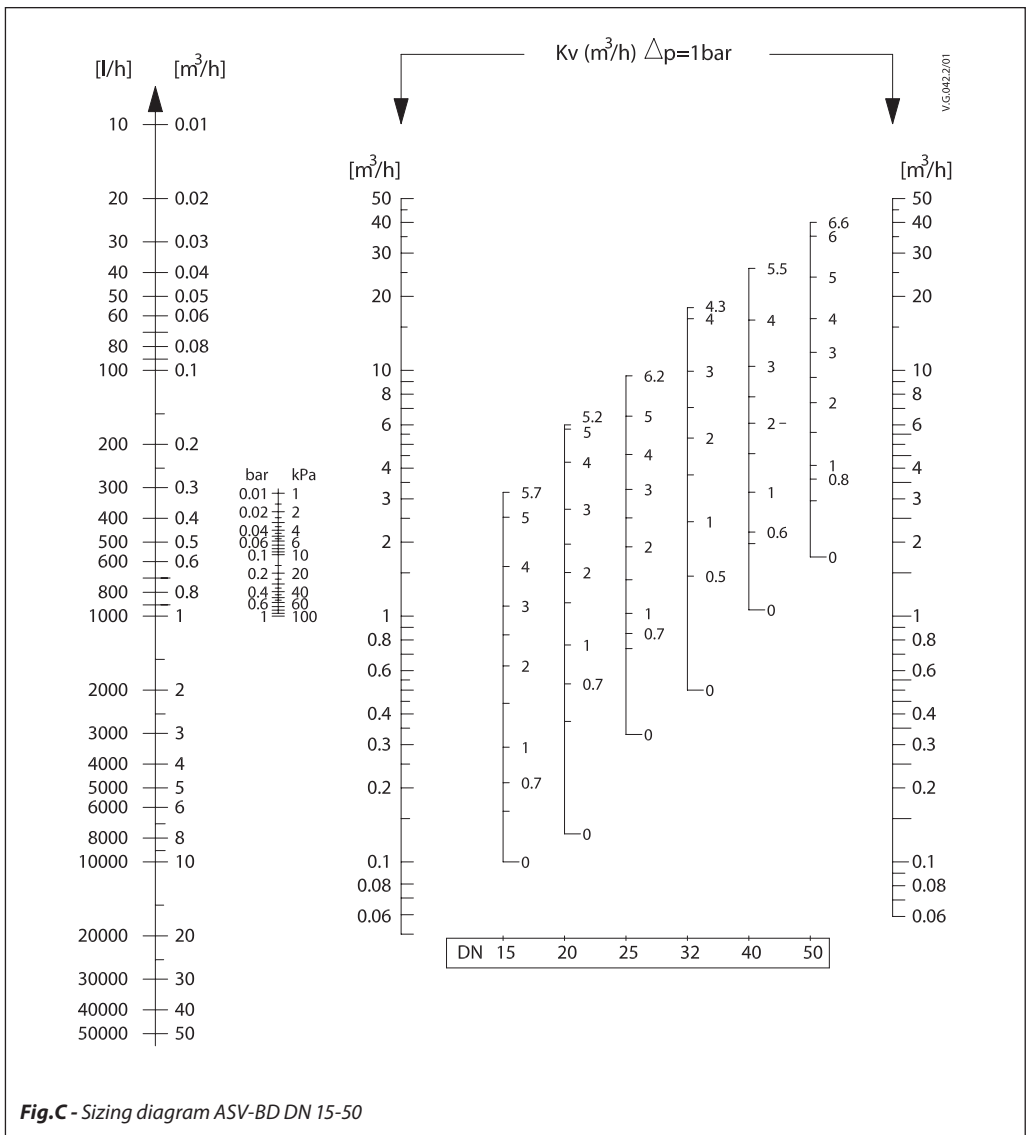

Fig.C - Sizing diagram ASV-BD DN 15-50

Appendix A

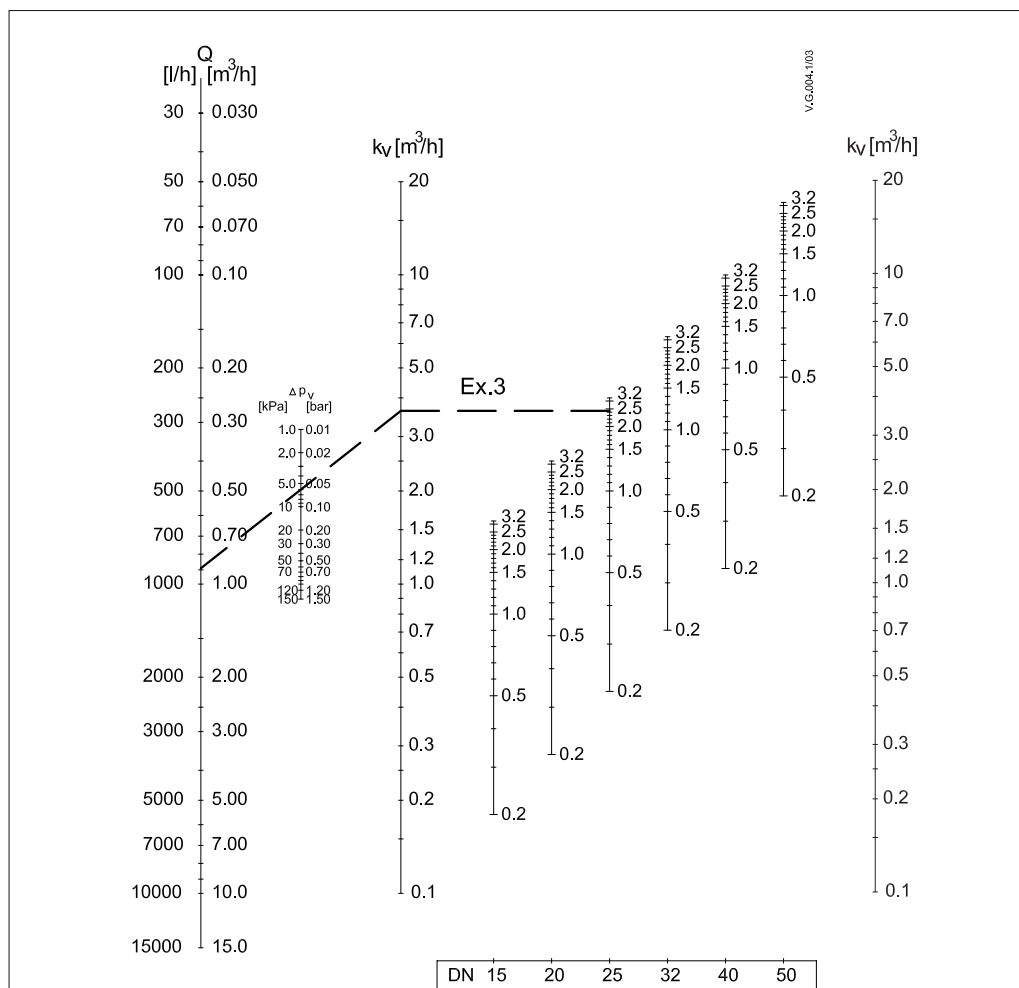

Fig. D Sizing diagram ASV-I, DN 15-50

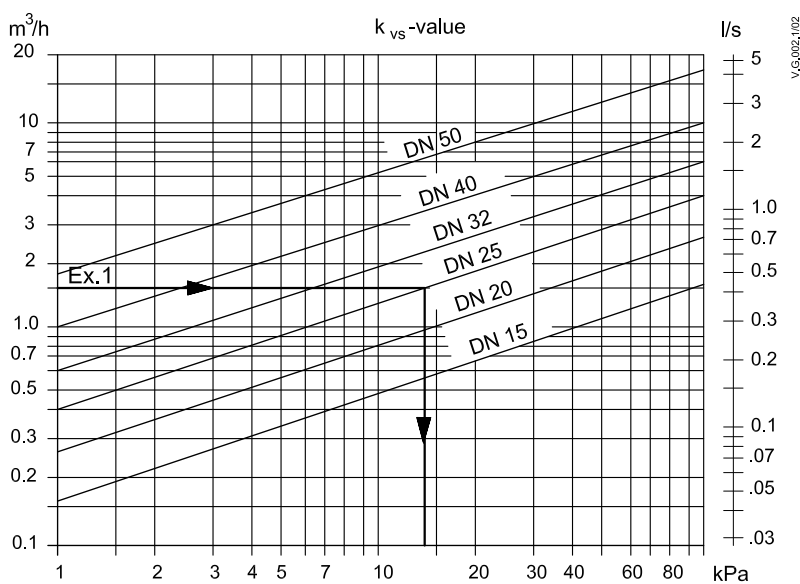

Fig. E Pressure drop over ASV-M valves, DN 15-50





# Data sheet

## Insulation, fittings

### Description

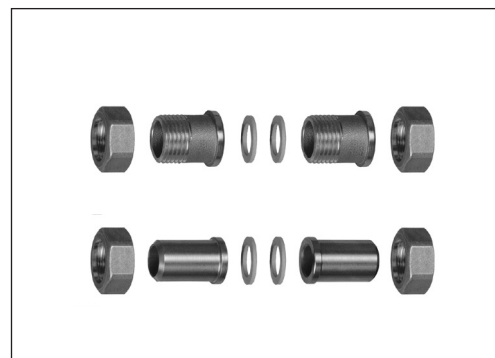
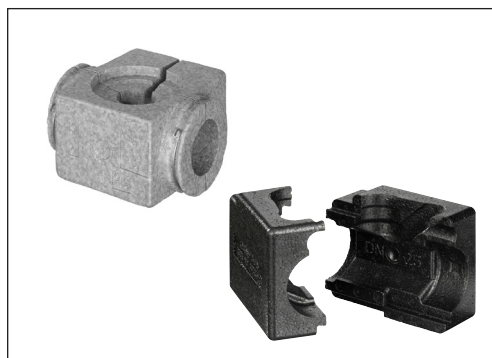

#### Insulation

The EPS styropor packaging in which the valve is supplied can be used as insulation in systems where the temperature does not exceed 80 °C under continuous operation.

ASV-BD valve is supplied together with EPP insulation cap. ASV-BD insulation cap offers click on feature for fast and easy mounting on the valve. Insulation cap in EPP is offered for use at higher temperatures, up to 120 °C.

Both materials (EPS and EPP) are approved in accordance with fire class standard B2, DIN 4102.

#### Fittings

For valves with external thread Danfoss offers threaded or welded tailpieces as accessory.

#### Materials

Nut .....brass  
 Tailpiece welding .....steel  
 Tailpiece threaded .....brass

### Ordering

#### EPP insulation cap for ASV

Connection	Code No.
DN 15	003L8170
DN 20	003L8171
DN 25	003L8172
DN 32	003L8173
DN 40	003L8139

#### EPP insulation cap for ASV-BD

Connection	Code No.
DN 15	003Z4781
DN 20	003Z4782
DN 25	003Z4783
DN 32	003Z4784
DN 40	003Z4785
DN 50	003Z4786

#### Fittings

Type	Comments	to pipe	to valve	Code No.
	Tailpiece threaded (1 pcs.)	R ½	DN 15	003Z0232
		R ¾	DN 20	003Z0233
		R 1	DN 25	003Z0234
		R 1 ¼	DN 32	003Z0235
		R 1 ½	DN 40	003Z0273
		R 2	DN 50 (2 ¼")	003Z0274 <sup>2)</sup>
			DN 50 (2 ½")	003Z0278 <sup>1)</sup>
	Tailpiece welding (1 pcs.)	DN 15	DN 15	003Z0226
		DN 20	DN 20	003Z0227
		DN 25	DN 25	003Z0228
		DN 32	DN 32	003Z0229
		DN 40	DN 40	003Z0271
		DN 50	DN 50 (2 ¼")	003Z0272 <sup>2)</sup>
			DN 50 (2 ½")	003Z0276 <sup>1)</sup>

**Note:** ASV-PV DN 50 (2 ½") and ASV-I/M DN 50 (2 ¼") have different size connection.

<sup>1)</sup> To use with ASV-PV DN 50 valves

<sup>2)</sup> To use with ASV-I and ASV-M DN 50 valves.

Dimensions - insulation

**ASV-I/M/P/PV**

DN	A	B	C	D
	mm			
15	61	110	111	37
20	76	120	136	45
25	100	135	155	55
32	118	148	160	70
40	118	148	180	70

**ASV-BD**

DN	A	B	C
	mm		
15	79	85	122
20	84	85	122
25	99	85	122
32	132	85	185
40	138	130	185
50	138	126	185

ASV-PV tender text

1. Tender text
  - a. Product is differential pressure controller for automatic hydronic balance of heating and cooling systems.
  - b. The differential pressure controller should be based on integrated membrane element.
  - c. When used in radiator heating application, for efficient and reliable performance 5-25kPa setting range should be used.
  - d. Valves should have shut-off function separated from the setting mechanism. Shut-off service function should be possible with a hand knob.
  - e. The setting of differential pressure should be hidden to prevent unauthorized change of setting.
  - f. The differential pressure setting should be linear throughout the setting range (1 turn 1 kPa or 1 turn 2 kPa depending on dimension).
  - g. The setting range should be interchangeable via spring change in dimensions DN 15-40 without draining the system. Spring should be changeable under pressure.
  - h. Drain function should be integrated in valve in dimension range of DN 15-40.
  - i. Packaging of differential pressure controller in the DN 15-40 range should contain impulse tube (1,5 m) and thermal insulation.
  - j. Valve should be delivered in reliable packaging for safe transport and handling.
2. Product characteristics:
  - a. Pressure class: PN 16
  - b. Temperature range: -10 ... +120 °C.
  - c. Connection size: DN15-100
  - d. Connection type (depending on dp setting range): Internal thread ISO 7/1 (DN15-40), External thread ISO 228/1 (DN15-50) and Flange EN 1092-2 (DN65-100)
  - e. Δp setting range: 5-25 kPa (DN15-50), 20-60 kPa (DN15-40), 20-40 kPa (DN 50-100), 35-75 kPa (DN 50-100) and 60-100kPa (DN65-100).
  - f. Installation: differential pressure controller should mounted on return pipe with connection via impulse tube to supply pipe.

Nominal diameter: \_\_\_\_\_  
 Connection: \_\_\_\_\_  
 Adjustment range from - to \_\_\_\_\_ kPa  
 Produced by: Danfoss Type: ASV-PV  
 EPP insulation: \_\_\_yes\_\_\_ / \_\_\_no\_\_\_  
 Ordering no.: 003L\_\_\_\_\_



