

G20 (T) (TD),
 G25 (T) (TD) &
 G30 (T) (TD)
 Rotary Screw
 Air Compressor
 Units
 - - -
 Installation
 And
 Start-up Data

Contents:	Page:
Quick Start	2
Safety Precautions	5
Unpacking and Inspection	6
Installation – Mechanical	7
Lubrication	10
Installation – Electrical	11
Start-up Procedures	14
Preventative Maintenance Schedule	15
Common Compressor Faults	17
Variable Speed Drive	18
Separator Filter & Refrigerated Air Dryer	21
Trouble-Shooting Guide	24
Warranty	27



Please read this manual before installing or using your Air Compressor Unit. It contains valuable information that will help in the receiving, installation, use, and maintenance of the Unit.

Please keep this manual in a safe place for future reference.

All of the information, policies, and procedures in this reference manual apply exclusively to DV Systems.

If you require assistance, please contact your local DV Systems Distributor or Authorized Service center. You may contact the manufacturer directly as follows:

Phone:	(705) 728-5657 (Canada) (704) 799-0046 (USA)	Web:	www.dvcompressors.com
Fax:	(705) 728-4974 (Canada) (704) 799-0355 (USA)	Email:	sales@dvcompressors.com (Canada) orders@dvcompressors.com (USA)

Quick Start

Mechanical Installation.

(Refer to Page 6)

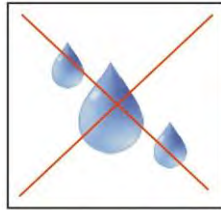

- The Unit should be located in a dry, clean, cool, dust free, and well ventilated area.
- Allow a minimum 18" (458mm) around and 36" (915mm) above Unit.
- The ambient temperature should be between 10°C and 40°C (50°F and 104°F).

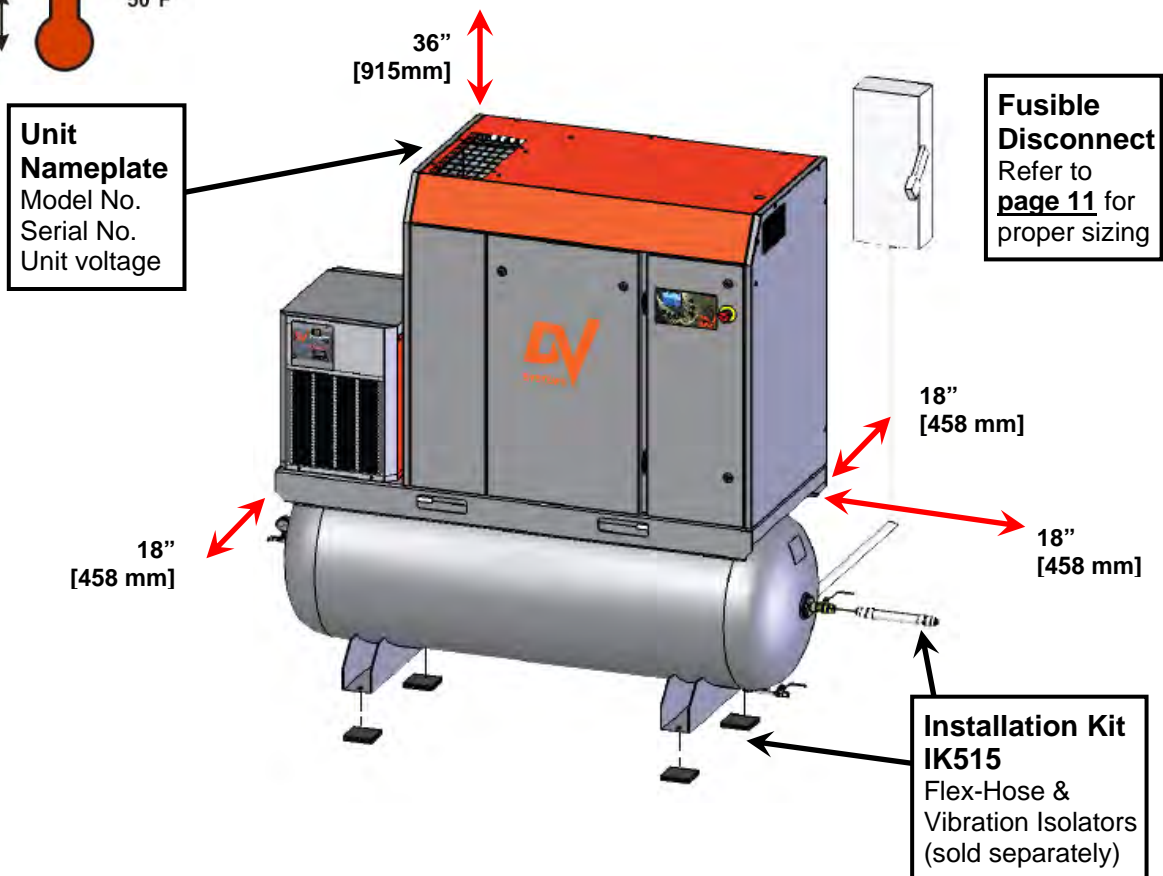

- Ensure that the floor under the Unit is smooth, level and capable of bearing the weight of the Compressor.
- If installed in a compressor room, ensure that the room is adequately ventilated

Note: Dimensions indicated are typical for all variations of 'G Series' Units, ie base mounted and horizontal.

Quick Start (cont'd)

Shipping Cleats.

- The 'G Series' Screw Units are shipped with (3) Shipping Cleats that must be removed prior to operating the Unit.
- (2) Cleats are located under the Belt / Pulley Housing as shown at right.
- (1) Cleat is located under the Motor Mount as shown at right.

(1) Cleat at Motor Mount



(2) Cleats at Belt / Pulley Housing

Lubrication.

(Refer to Page 10)

- Ensure the oil level in the Air End is to the level as shown while at rest.
- The Unit is equipped with the Sight Glass
- The oil level should be close to the center of the Oil Sight Glass, while at rest.
- **Check the oil after the Unit has been at rest for a minimum of 5 minutes.**

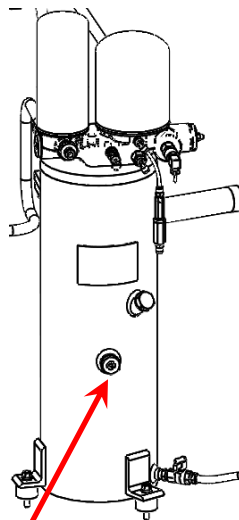

Correct
Oil Level



Rotation.

(Refer to Page 12)

- Units are equipped with Advanced Phase Detection feature which prevents Units from rotating in the reversed direction.
- An 'E:0090 Phase Sequence' Error will appear on the Controller Screen if the phase sequence is incorrect. If this occurs, simply switch the incoming leads 'L1' and 'L3' at the Control Panel

Note: Units with serial number 077690 and earlier may be equipped with Anti-Rotation Switches.

'E:0902 Anti Rotation' will appear on the Controller Screen if the rotation is incorrect. If this occurs, change 'L1' and 'L3' at the Control Panel.

Quick Start (cont'd)

Unit Operation.

Shown below is the 'CSC300' Controller which regulates the operation of the Unit. It is used to start and stop the Unit, and it provides information as to system pressure, temperature, etc.

Starting the Unit: Press the '**Start**' Button.

Stopping the Unit: Press the '**Stop**' Button

Note:

1. Do not stop the Unit using the 'Emergency Stop' Button unless there is a danger to the product or of personnel injury.
2. Do not stop the Unit by use of a disconnect or breaker.



Using the Emergency Stop Button, disconnect, or breaker to stop the Unit will not allow the Unit to go through an unloading sequence, and could result in damage to the Motor, Starter, or other electrical components. Damage caused in this manner is not covered by the manufacturers Warranty.



Start.
Starts the Unit.

Stop.
Causes the Unit to enter 'Idle' mode and then shut off.

Emergency Stop.
Will quickly shut the Unit off. Is only to be used in an emergency.



Digital Readout.
Indicates Unit pressure, temperature, etc.

Enter, Up, Down & Escape.
Used in the programming and changing of operating parameters of the Unit.

Safety Precautions

In order to operate the Compressor Unit safely and correctly, we have opted to use the following symbols to make you aware of important points. These points relate to user safety and preventing equipment problems. Please pay close attention to these sections.



Important safety Information.
A hazard that may cause serious injury or loss of life.

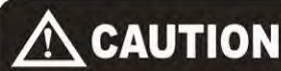





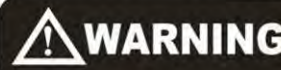

Important information that indicates how to prevent damage to equipment, or how to avoid a situation that may cause minor injury.



Information that you should pay special attention to.



The following hazards may occur during the normal use of the equipment. Please read the following chart.

<u>Area:</u>	<u>Hazard:</u>	<u>Safeguards:</u>
What to look for.	What may occur if precautions are not observed.	How to avoid the hazard.
	Tampering with the Unit while under full or partial pressure may cause an explosion.	Relieve all pressure from the Unit before attempting any repair or maintenance work.
	As the Unit starts and stops automatically, serious injury may result from working on the Compressor with the power still in the 'on' position.	Shut off all power to the Unit before attempting to repair or maintain the Compressor.
	As the Unit starts and stops automatically, do not come into contact with moving parts.	Shut off all power to the Unit before attempting to repair or maintain the Compressor.
	Air compressed by the Unit is not suitable for inhaling. It may contain vapours harmful to your health.	Never breath untreated compressed air produced by the Compressor.
	Compressor Air End, Motor, and Tubing become hot when running. Touching these areas may cause serious burns.	Never touch the Air End, Motor, or Tubing during or immediately after operation.
	As the electrical components on the Compressor are General Purpose, there is a potential for explosion, should vapours be present in the area.	Do not install in hazardous locations. The Compressor must be a minimum of 20 feet (6.1 meters) from any source of potentially explosive vapours.

Unpacking and Inspection

A white warning triangle with an exclamation mark inside, set against a black rounded rectangular background.

NOTE

Each DV Systems Air Compressor is carefully tested and inspected before shipment. Though every attempt is made to ensure the safe and complete shipment of our product, freight damage or misplacement of goods may occur.

Shipments of DV Systems products are the property of the Consignee when the products leave our facility. DV Systems Inc. is not responsible for any damages or shortages caused to the product after it has left our shipping dock.

It is the responsibility of the receiver of the goods, either the Distributor or Customer, to ensure that the product has been shipped in full, and has arrived in suitable condition. Damage to the product may not be visible at time of off-loading, but may only become apparent upon unpacking or start-up.

Some areas to initially check are as follows:

- a) Check for damage to the crating and/or packaging.
- b) Check the exterior of the Cabinet for damage, either cosmetic or mechanical.
- c) If there is mechanical damage, open the Cabinet to determine whether there is any internal damage to the Unit.

Should there be damage to the product or shortages in shipment:

- 1) Stop any further unpacking or operation of the product.
- 2) Make note of the problem on the Freight Bill, should it concern a shortage or visible damage to the product.
- 3) Should the damage be noticed only after the product has been received, contact the transport company immediately to file a claim.
Depending on the problem, it may be wise to photograph the damage. Also, it may be wise to discuss with the carrier representative the time allotted to give notice of loss or damage to the product; there may be guidelines which limit timeframes of same.
- 4) Do not attempt further unpacking or operation of the product. Also, do not discard any packing material used.
- 5) A Loss or Damage Claim must be submitted to the carrier and supported by the following documents:
 - Copy of Freight Bill of Lading
 - Copy of the Invoice and Estimate to repair, in case of damage
 - Damage Report
 - Copy of photos, if applicable

Installation – Mechanical

Moving of the Unit.

When moving the Air Compressor, the forklift or hand lift forks go under the Unit from the directions as indicated.

When lifting from position 'A', use extended forks.

Please be advised that care must be taken when moving and positioning the Units as they are top heavy.

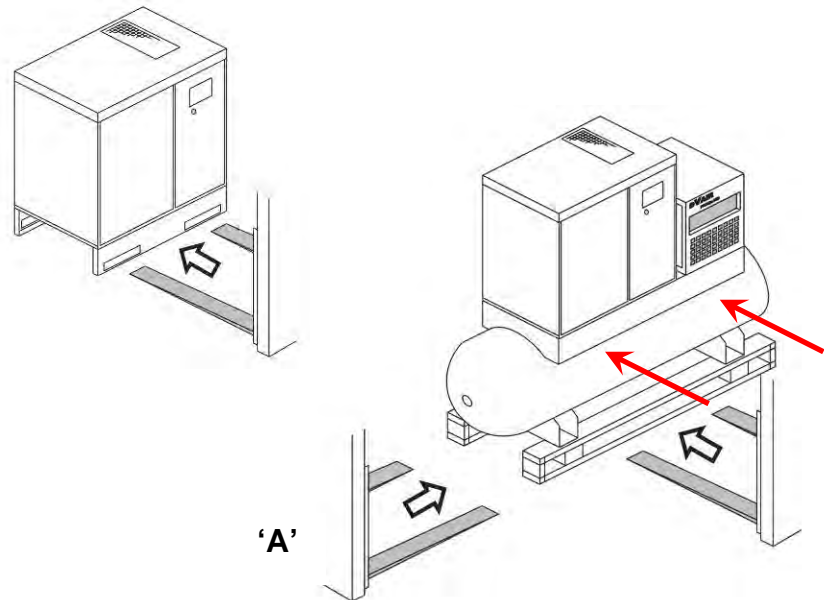

Location of the Unit.

Items to consider when installing the Unit are as follows:

- The Unit should be located in a dry, clean, cool, dust free, and well ventilated area. If possible, the Compressor should be located in a separate room or area, away from the general operations of the shop.
- Allow a minimum of 18" (458mm) around and 3 feet (915mm) above the Unit for easy access to the various sides, this being for both the proper ventilation of the Unit and ease of servicing.
- Ensure that the floor under the Unit is smooth, level and capable of bearing the weight of the Compressor. The Compressor must sit squarely on the floor.
- If installed in a compressor room, ensure that the room is adequately ventilated. (One Horsepower produces approximately 2500 BTU/HR.) See Pages 8 and 9.
- The ambient temperature should be between 50°F and 104°F (10°C to 40°C).

- If installing the Unit on a mezzanine, ensure that the structure can safely support the weight of the Unit. As well, the sound level of the Unit may increase due to the harmonics created by the structure; use Vibration Pads to lessen this.

Many common Compressor problems can be attributed to the location or installation of the Unit. Make sure the Unit is in a suitable location, and installed correctly.



The Compressor must not be operated in a confined area where the heat from the Unit cannot readily escape.

Installation – Mechanical (cont'd)

Shown below and on the following page are items which assist in making a good installation. These are both intake and exhaust ductwork, helping the Unit to a) draw in clean outside air and b) exhaust the warmer air away from the Unit. The warmer air may be used, with the inclusion of a damper in the exhaust ducting, to warm the interior of the building during the colder months of the year.

Intake and Exhaust Ducting – Base Mounted Unit

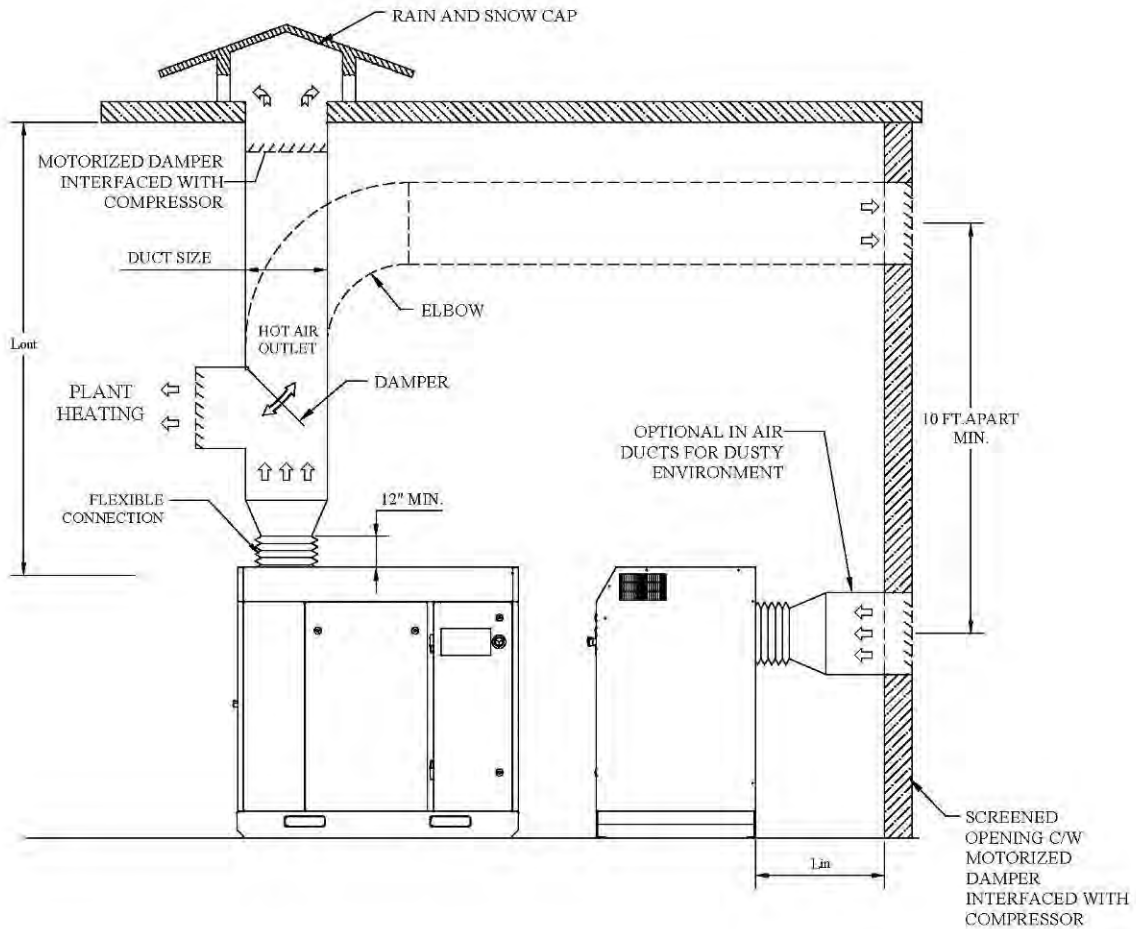

MODEL	HP	HEAT LOAD (BTU/HOUR)	COOLING AIR (CFM)	RECOMMEND MIN. DUCT SIZE	MAX. DUCT LENGTH $L_{in} + L_{out}$	AIR OUT OPENING AT COMPRESSOR
G20	20	50,928	1520	Ø 16" (CIRL.) 16" x 16" (RECT.)	70 Ft. (0 ELBOW) 45 Ft. (1 ELBOW) 20 Ft. (2 ELBOW)	OUTLET SIZE 7 11/16" x 16 5/16"
G25	25	63,660	1830	Ø 16" (CIRL.) 16" x 16" (RECT.)		INLET SIZE 11 5/8" x 14 1/4"
G30	30	76,392	1830	Ø 16" (CIRL.) 16" x 16" (RECT.)		

NOTE:

1. DUCTING SIZE BASED ON GALVANIZED STEEL DUCTS.
2. MAXIMUM PRESSURE DROP DUE TO DUCTING SYSTEM SHOULD BE WITHIN 0.1 IN. OF WATER.
3. ADDITIONAL VENTILATION SYSTEM NEEDED FOR PRESSURE DROP EXCEED ABOVE LIMIT.
4. OPERATION TEMPERATURE: MIN. 10°C (50°F) ~ MAX. 40°C (104°F).
5. ANY DEVIATION FROM ABOVE INSTALLATION, CONSULT DEVAIR TECHNICAL SUPPORT.

Installation – Mechanical (cont'd)

Intake and Exhaust Ducting – Tank Mounted Unit

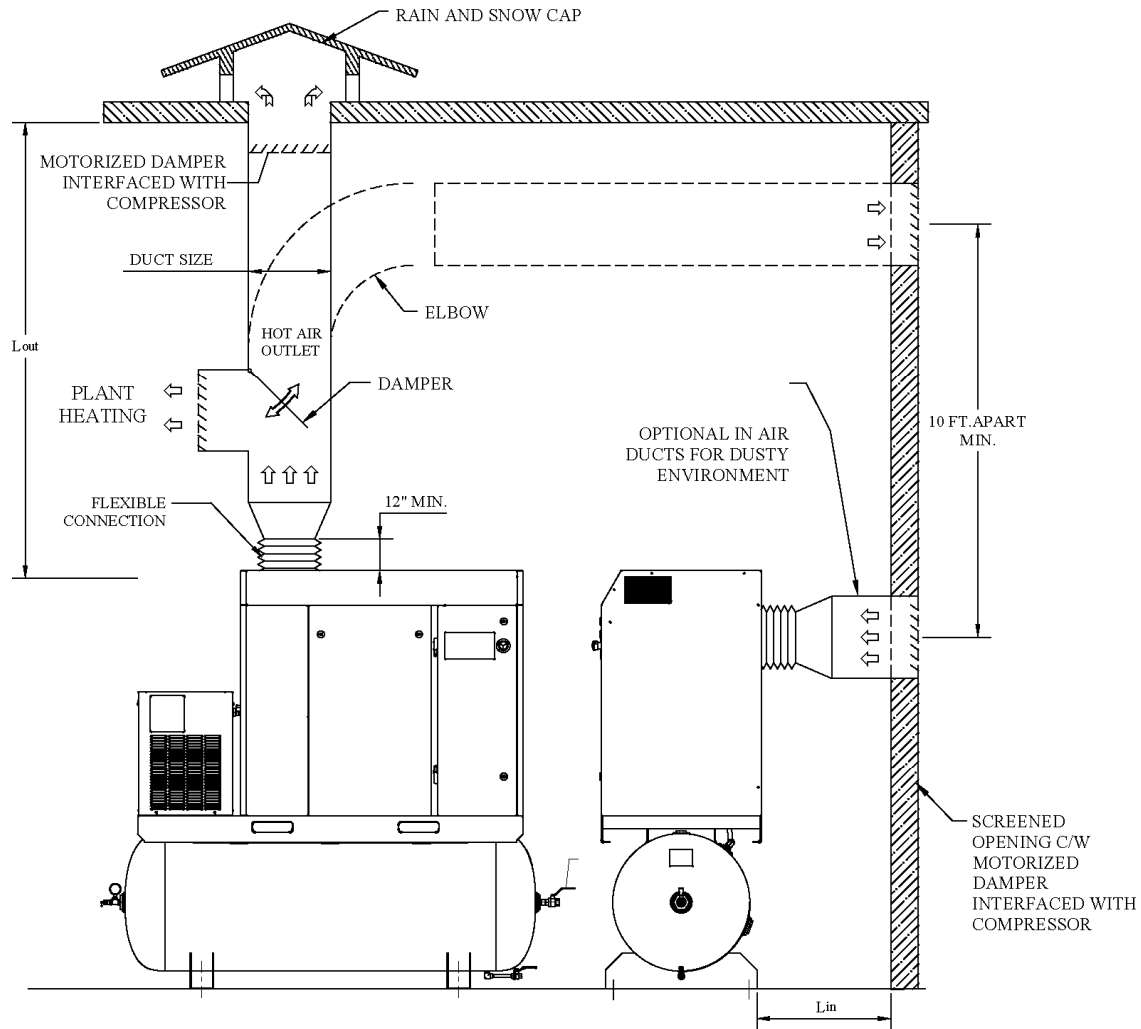

MODEL	HP	HEAT LOAD (BTU/HOUR)	COOLING AIR (CFM)	RECOMMEND MIN. DUCT SIZE	MAX. DUCT LENGTH $L_{in} + L_{out}$	AIR OUT OPENING AT COMPRESSOR
G20TD	20	50,928	1520	Ø 16" (CIRL.) 16" x 16" (RECT.)	70 Ft. (0 ELBOW) 45 Ft. (1 ELBOW) 20 Ft. (2 ELBOW)	OUTLET SIZE 7 11/16" x 16 5/16"
G25TD	25	63,660	1830	Ø 16" (CIRL.) 16" x 16" (RECT.)		INLET SIZE 11 5/8" x 14 1/4"
G30TD	30	76,392	1830	Ø 16" (CIRL.) 16" x 16" (RECT.)		

NOTE:

1. DUCTING SIZE BASED ON GALVANIZED STEEL DUCTS.
2. MAXIMUM PRESSURE DROP DUE TO DUCTING SYSTEM SHOULD BE WITHIN 0.1 IN. OF WATER.
3. ADDITIONAL VENTILATION SYSTEM NEEDED FOR PRESSURE DROP EXCEED ABOVE LIMIT.
4. OPERATION TEMPERATURE: MIN. 10°C (50°F) ~ MAX. 40°C (104°F).
5. ANY DEVIATION FROM ABOVE INSTALLATION, CONSULT DEVAIR TECHNICAL SUPPORT.

Lubrication

Initial Start-up.

Each Compressor Unit built is extensively tested at the factory before shipment. The Unit is shipped with the original oil in it as used for testing purposes.

Check the Oil level and for any Oil leaks on a daily basis. This must be done when the Unit is off. Top up the Oil level on a monthly basis.

Use only DV Systems 'DEV-3000' Synthetic Oil. Also, do not mix the 'DEV-3000' with any other lubricant.

Subsequent Oil Changes.

Drain the existing oil from the Unit. (Please be advised that the Unit cannot be drained fully of oil, as some oil may remain in various components ie Cooler, Tubing, etc.)

Fill the Oil Reservoir to the Metal Band on the External Oil Level Gauge as shown below. Do not under or overfill. See drawing below.

Use only DV Systems 'DEV-3000' Synthetic Oil, available in both 1 US gallon (3.8 litre) jugs or 5 US gallon (5 x 3.8 litre) pails. Any remaining oil may be used for 'top-ups'.

The 'MK-G20-30-1' Maintenance Kit includes:

- (1) 5 US Gallon Oil ('DEV-3000')
- (2) Oil Filter ('DSC-624')
- (1) Air/Oil Separator Filter ('DSC-001148')
- (2) Air Filter ('DSC-001961')
- (1) In Line Filter ('DSC-612')

The 'MK-G20-30-1' Kit is appropriate for Units of serial number '37162' and higher. Use 'MK-G20-30' Kit for Units of serial number '37135' and lower.

 **CAUTION**

Do not attempt to operate the Unit without first checking whether there is oil in the Oil Reservoir. Add oil as required. Serious damage may result from use, however limited, without oil.

 **CAUTION**

Use of improper oil may negatively affect Compressor performance or shorten Unit life. Resulting problems are not covered by the DV Systems Inc. Air Compressor Warranty.

 **CAUTION**

Condensation (water) may form in the Oil Reservoir with the oil. If this occurs, as the water will tend to settle on the bottom of the Reservoir, drain the water from the Reservoir until you notice oil draining. Top up the Reservoir with new oil using only the DV Systems 'DEV-3000' oil.

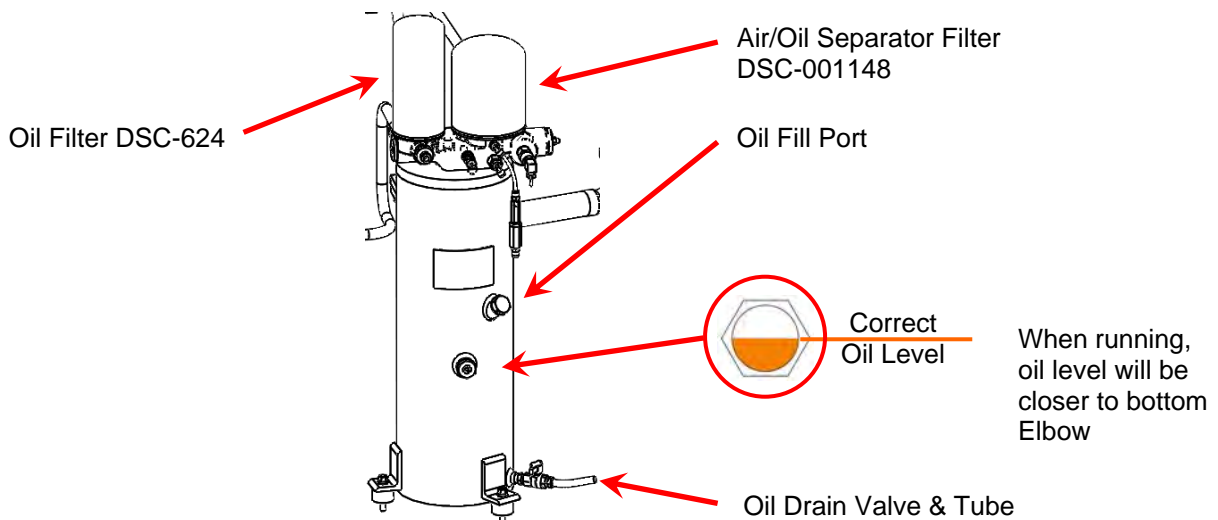

Installation - Electrical

General Information.

It is your responsibility to ensure that the Compressor Unit is electrically connected in a safe and correct manner. **Any electrical work should be carried out by a competent Electrician, and be done in such a way that it meets all applicable Codes and Regulations.**

Ensure that a suitable Fused Disconnect or Breaker (by others than DV Systems) is installed in the electrical supply before the Compressor Unit.

The sales drawing found at the back of this booklet indicates the amp rating for the Unit. This information is required in sizing a Disconnect, Fuses, and/or a suitable Breaker. As well, an electrical schematic is enclosed for reference.

Electrical wiring and conduit from the building supply, through the Compressor Cabinet, and to the Switch in the Compressor Control Panel, must be rated for 110°C (230°F) or higher.



- Failure to correctly connect the Compressor to your building's electrical services may result in serious personal injury or damage to the equipment.
- Install all covers and panels before applying power to the Unit.
- Before servicing the Unit, ensure the power source has been shut down and locked off.
- Read and understand the information contained in this manual before installing or operating the Unit.

Failure to observe any of the above precautions could result in severe personal injury or death, and/or damage to the Unit.

Fusible Disconnects.

- Ensure that all wiring, fusing, etc is done in a manner that meets with the appropriate codes and regulations.
- See the sales drawings and electrical schematic contained in this manual for information about Motor nameplate amps, this is used to determine the appropriate Disconnect / Breaker and Wiring sizes.
- Units equipped with Variable Speed Drives (VSDs) MUST use FAST-ACTING FUSES. Refer to the table below for fuse sizes.

Fixed Speed Units:

Use TIME-DELAY type fuse.

**Max. Allowable Fuse =
1.75 x Motor Full Load Amp**

VSD Units:

HP	Voltage	Fuse Type	Fuse Amp	DV Fuse Part No.	DV Disconnect Kit (Disconnect + Fuses)
25	200	DFJ/ HSJ	80	F080	FD-080
	230		70	F070	FD-070
	460		35	F035	FD-035
	575		35	F035	FD-035
30	200	DFJ/ HSJ	110	F110	FD-110
	230		80	F080	FD-080
	460		40	F040	FD-040
	575		35	F035	FD-035

Installation – Electrical (cont'd)



Do not attempt to operate the Unit without first checking whether there is oil in the Oil Reservoir. Add oil as required. Serious damage may result from use, however limited, without oil.

Electrical Connection.

The Electrician is to bring power to the Unit through the conduit hole located on the Top Panel. The Electrical Panel is accessible by means of opening the Unit Front RH Door as shown at right.

Refer to the enclosed sales drawing and electrical schematic in determining the correct Disconnect / Breaker and Wire size.

Bring power to L1, L2, L3

Conduit Opening

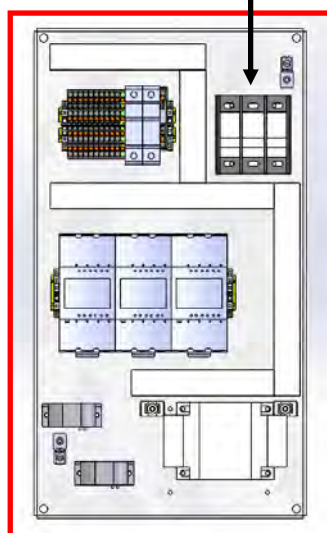

Motors.

Wiring must be done in a manner that the full Motor nameplate voltage +/- 10% is available at the Motor terminals during start-up. Contact your local Distributor or Service Centre if additional information is needed.

The Warranty that exists on the Electric Motor is that of the original manufacturer. In the event of a Motor failure, contact your DV Systems Distributor or Service Centre for the location of the nearest authorized Motor Service Centre.

Motor/Air End Rotation.

It is critical that the Motor and Air End in the Rotary Screw Unit be turning in the correct manner. Irreparable damage will be done if the Unit rotates in the opposite direction.

This unit is equipped with Advanced Phase Detection which prevents unit from rotating in the reverse direction. If the following error is visible on the Screen and the Unit will not start, simply switch power leads L1 and L3. Press the 'Reset' key on the Controller to reset the error message.

E:0090 Phase Sequence

Note: If the Motor is replaced or Motor Leads are re-wired, visually check for correct Motor Rotation before installing the belts.

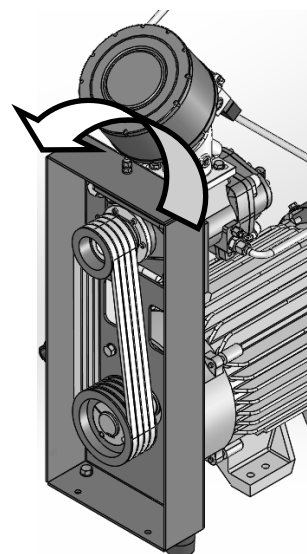



AC Motor Maintenance Instructions



Cleaning.

To ensure that the Motor operates at optimum temperatures and provides years of trouble-free service, periodically clean the outside of the Motor Housing of any build-up of dust, etc. Though it is not anticipated that, if installed correctly and in a suitable environment, there should be much build-up on the Motor, keeping the Housing clean will allow the Motor to operate more efficiently.

Lubrication.

This is a ball bearing motor. The bearings have been lubricated at the factory. Motors that do not have re-grease capability are factory lubricated for the normal life of the bearings.

Some motor designs use different bearings on each motor end. Noted below is a chart outlining the interval at which the bearings of Motor should be lubricated, this based on the Bearing Sizes. This must be part of a regular maintenance schedule.

Motor HP	Interval in Hours	Drive End *		Opposite Drive End **
		Weight of Grease Ounces (Grams)	Volume of Grease In ³ (Teaspoon)	Weight of Grease Ounces (Grams)
20 / 25 /30	2,000	0.61 (17)	1.2 (3.9)	0.23 (7.2)

*Drive End would be the end that is connected to the driven device (air end).

**Opposite Drive End would be the end that is connected to the fan assembly.

The above chart is based on a standard environment in which the Motor is operating of 40°C (104°F). For other conditions, please multiply the Hour Interval from the chart above by the factor as indicated below.

Severity of Duty	Factor	Environmental Conditions
Standard	1.0	40°C (104°F) , clean, little corrosion
Severe	0.5	50°C (122°F), moderate dirt, corrosion
Extreme	0.1	> 50°C (122°F), severe dirt, abrasive dust
Low Temperature	1.0	< 30°C (86°F)

Lubricant.

Baldor motors are pre-greased, normally with Mobil Polyrex EM. Equivalent and compatible greases are Texaco Polystar, Chevron SRI #2, and Shell Dolium BRB.

Start-up Procedures



Do not attempt to operate the Unit without first checking whether there is oil in the Oil Reservoir. Add oil as required. Serious damage may result from use, however limited, without oil.

Unit Controls

Start Button

Allows the Unit to start.



Stop Button

Use this to shut the Unit off. Allows the Unit to idle and then stop after several seconds.

Emergency Stop Button

Do not use to normally stop the Unit. To be used to stop the Unit in emergencies only. Normal use will damage electrical controls and Shaft Seal.

Initial Start-up

- 1) Remove the LH Front Access Panel, and ensure that there is sufficient Oil in the Oil Reservoir. Refer to the 'Lubrication' section (page 10) in this manual for proper type and level of Oil.
- 2) Do a visual inspection of the Unit, and ensure that all fasteners are sufficiently tightened. This must be done, as some fasteners may become loose in transit.

- 3) Place the Fused Disconnect / Breaker in the 'On' Position. Check that there is power to the Controller.
- 4) During normal operation of the Unit, keep the Access Panels closed at all times.
- 5) Ensure the Ball Valve on the Unit is closed, press the 'Start' Button, and run the Unit up to maximum pressure. The Unit will run up to approx. 120 psi (8.3bar), at which point the Motor will continue to run but not compress air.
- 6) Once the Unit reaches 120 psi (8.3bar), it will idle for 8 or 10 minutes and shut off. For VSD units, the unit will idle for 2 minutes and shut off.
- 7) Open the Ball Valve slightly and allow the air to bleed from the Tank. Once the pressure reaches approx 100 psi (6.9bar), the Unit will start and begin to compress air after a short delay. For VSD units, this pressure is 10 psi below the cut-out pressure.
- 8) Measure the amp draw as the Unit reaches maximum pressure.
- 9) Close the Ball Valve, allow the Unit to reach maximum pressure, idle, and shut off. Once off, check the various fittings etc inside the Cabinet to ensure there are no internal leaks.
- 10) Once you are confident that there are no internal leaks, the Unit will be ready for normal use.
- 11) Register the Unit to activate the Warranty by completing the Warranty Registration Card by Fax.



Do not place any materials in close proximity to the Compressor. Placing materials against or close to the Unit will limit the cooling required, and could lead to premature failure.



Shut off all power to the Compressor Unit before attempting any repair or maintenance.

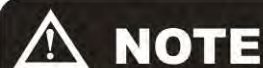

Adjusting the settings of the Controller could adversely affect the performance of the Unit. Only those individuals with knowledge of the Unit should make any adjustments.

Preventative Maintenance Schedule



When servicing the Air Compressor, shut off all power to the Unit, and drain it of air pressure.



It is the responsibility of the Compressor owner to ensure that a regular Maintenance Schedule is followed.

Noted on the following pages are general Maintenance guidelines based on average working conditions. Should the Unit be worked under extreme conditions, please contact your DV Systems Distributor for further input. As well, all maintenance/service work must be carried out by a qualified Technician.

The typical operating temperature of the Unit, this dependent on ambient temperatures, is between 70°C and 85°C (158°F and 185°F).

If the operating temperature of the Unit is too low (less than 70°C (158°F)):

- condensation will build up in the system and mix with the oil, causing internal component problems in the Unit
- Change the ambient conditions to increase the operating temperature.

If the operating temperature of the Unit is too high (above 85°C (185°F)):

- the oil will oxidize and lose it's properties, this causing internal damage to components as well
- to combat this, the oil must be changed more often than noted below.

Note: For Compressor Units used in an environment where the ambient temperature is above 32°C (90°F), the components marked with a '# ' (on the chart on the following page) must be changed more frequently.

Regular Maintenance Items.

DV Systems offers a Maintenance Kit for your Unit, namely:

MK-G20-30-1 20 to 30 HP 'G Series' Units
(Unit Serial # '37162' and higher)

Each Kit consists of the following items, these suitable for approximately 4000 hours of operation.

- | | | |
|-----|-------------------|--------------------------|
| (1) | DEV-3000 | 5 Gal. of Synthetic Oil |
| (2) | DSC-624 | Oil Filter |
| (1) | DSC-001148 | Air/Oil Separator Filter |
| (2) | DSC-001961 | Air Filter |
| (1) | DSC-612 | Inline Filter |

For Units with a serial number of '37135' and lower, order Kit 'MK-G20-30'.

Internal Access for Maintenance.

The internal components of the Unit are accessible for servicing by way of removing the LH Front Panel as shown.

The Belt access is by way of the RH Side Panel.

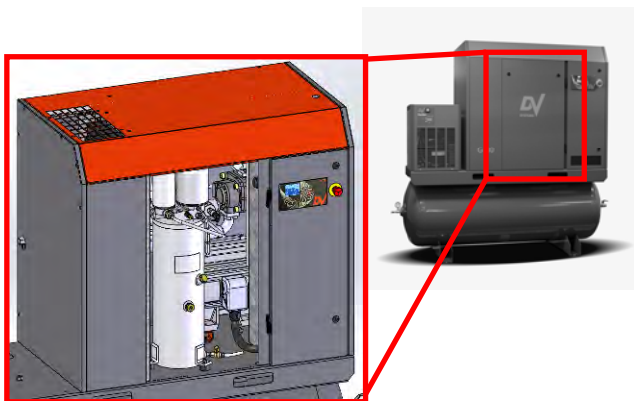



Preventative Maintenance Schedule (cont'd)

Maintenance Item:	Daily	Maintenance Interval (in 000's of Hours)																			
		2	4	6	8	10	12	14	16	18	20	22	24	26	28	30	32	34	36	38	40
Compressor Room																					
Temperature	Inspect	Ambient Temperature should be between 10°C and 40°C (50°F and 104°F)																			
Cleanliness	Inspect																				
Air Compressor Unit																					
Check Oil Level	Inspect																				
Replace Oil # (See Note b)	(1)				X				X				X			X			X		X
Replace Oil Filter #	(2)		X		X		X		X		X		X		X		X		X		X
Replace Air / Oil Separator #	(3)				X				X				X				X				X
Replace Air Intake Filter #	(4)	X	X	X	X	X	X	X	X	X	X	X	X	X	X	X	X	X	X	X	X
Check Belt Tension		X	X	X		X	X	X		X	X	X		X	X	X		X	X	X	
Replace Belts					X					X					X				X		X
Replace Tank Relief Valve							X							X					X		
Replace Solenoid (5)					X				X					X				X			X
Rebuild Intake Valve (6)					X				X					X				X			X
Rebuild Thermo Valve (7)							X							X					X		
Rebuild Minimum Pressure Valve (8)					X				X					X				X			X
Replace Scavenge Line Filter (9)					X				X					X				X			X
Motor Bearing Lubrication		Refer to Motor Manufacturer's Recommendations on Page 13																			

- Notes:**
- a) For Compressor Units used in an environment where the ambient temperature is above 32°C (90°F), or b) where the Unit temperature runs regularly above 80°C (175°F), the components marked with a '#' must be changed twice as often (example: in 4000 hours instead of 8000), and not as noted above.
 - b) The DV Systems Oil used in the Rotary Screw Units is rated as an 8000 hour Oil. A complete Oil change must be done every 8000 hours of Unit operation, or every 12 months, whichever occurs first. Please refer to the Warranty on Page 27 for further information.
 - c) If a component, during a regular inspection, has proven to be defective or unfit for regular operation, it must be repaired or replaced.

Parts and Repair Kits based on the above chart are as follows:

- | | | |
|-----|--------------------------------|---|
| (1) | Oil: | DEV-3000 |
| (2) | Oil Filter | DSC-624 |
| (3) | Air / Oil Separator: | DSC-001148 |
| (4) | Air Intake Filter | DSC-001961 (for Units of s/n '37162' and greater) |
| (4) | Air Intake Filter | DSC-001193 (for Units of s/n '37135' and lower) |
| (5) | Solenoid | DSC-002052 (for Units of s/n '37162' and greater) |
| (5) | 2 Way Solenoid | DSC-162 (for Units of s/n '37135' and lower) |
| (5) | 3 Way Solenoid | DSC-140 (for Units of s/n '37135' and lower) |
| (6) | Intake Valve Repair Kit | DSC-001999 (for Units of s/n '37162' and greater) |
| (7) | Thermo Valve Repair Kit: | DSC-111-1 |
| (8) | Minimum Pressure Valve Kit: | DSC-231 |
| (9) | Scavenge Line 'In Line' Filter | DSC-612 |
| | VSD Ambient Filter | DSC-001447 |
| | VSD Separation Foam | DSC-002897 |

As noted previously, the 'MK-G20-30-1' Maintenance Kit (for Unit serial numbers '37162' and higher) includes the following items:

- | | | |
|-----|-------------------|--------------------------|
| (1) | DEV-3000 | 5 Gal. of Synthetic Oil |
| (2) | DSC-624 | Oil Filter |
| (1) | DSC-001148 | Air/Oil Separator Filter |
| (2) | DSC-001961 | Air Filter |
| (1) | DSC-612 | In-Line Filter |



Common Compressor Faults

Common Faults.

Noted below are the most common Faults experienced.

'CSC300' Alarms.

There is an issue with the Unit, but it will still operate.

<u>Code:</u>	<u>Description:</u>	<u>Most Common Items to Check:</u>
A:0083	Motor phase imbalance	Check supply voltage, fuses and cable
A:0119	Delivery Pressure High	Solenoid not working, Intake Valve Orifice clogged, Transducer dirty or faulty, pressure changed incorrectly, alternate external pressure source
A:0129	Delivery Temperature High	Ambient temp high, Unit dirty, low oil level, no air flow through Unit, Temp Sensor defective
A:2816	Power Failure Occurred	Press 'Reset' Button and restart Unit
A:4819	Routine Service Due	Service Unit and reset Service Timer (Page 'P16' on Controller)
A:4809	Grease Service Due	Service motor and reset Grease Service Timer (Page 'P16' on Controller)

'CSC300' Shutdown Errors.

There is an issue with the Unit, and the Unit will not operate until the Fault has been addressed.

<u>Code:</u>	<u>Description:</u>	<u>Most Common Items to Check:</u>
E:0010	Emergency	Emergency stop switch is pressed
E:0070	Fan Motor Alarm	Check electrical connections
E:0082	Motor Overload	Motor drawing high amps, low voltage, high pressure settings, low oil level
E:0083	Motor phase Imbalance	Check motor connections in the control panel and motor connection box
E:0090	Phase Sequence	Rotation of Motor wrong, sequence order of supply cable incorrect
E:0091-0093	Phase L1/L2/L3 Fault	Check supply voltage, fuses and cable
E:0115	Delivery Pressure Sensor Fault	Transducer not making good electrical contact, or defective
E:0119	Delivery Pressure High	Solenoid Not working, Intake Valve Orifice clogged, Transducer dirty or faulty, pressure changed incorrectly, alternate external pressure source
E:0125	Delivery Temp Sensor Fault	Temperature Sensor not making good electrical contact, or defective
E:0129	Delivery Temperature High	Ambient temp high, Unit dirty, low oil level, no air flow through Unit, Temp Sensor defective
E:0902	Anti-Rotation	Rotation of Main Motor wrong, Solenoid Valve not relieving pressure
E:1902	Inverter Fault	Variable frequency drive tripped. Check VFD screen for more info.

Variable Speed Drive

Your DV Systems 'G Series' Rotary Screw Compressor Unit may have been equipped with an optional 'Variable Speed Drive', or 'VSD'. A Compressor with an integral VSD can handle the constant loads for an extended period of time (running at close to 100% duty cycle), but it can also run at slower speeds to accommodate lower air demands at other times of the day.

Variable Speed Drives can reduce the overall energy costs associated with operating the Compressor Unit by simply controlling the speed of the Motor and Air End to match consumption. As Rotary Screw Compressors using the variable speed technology match the varying air demands and therefore have the ability to impact your energy consumption, some energy providers have offered rebates when these Units are purchased. Consult your local energy provider to determine if this applies.

Shown below is a 'G Series' Unit with a Variable Speed Drive.

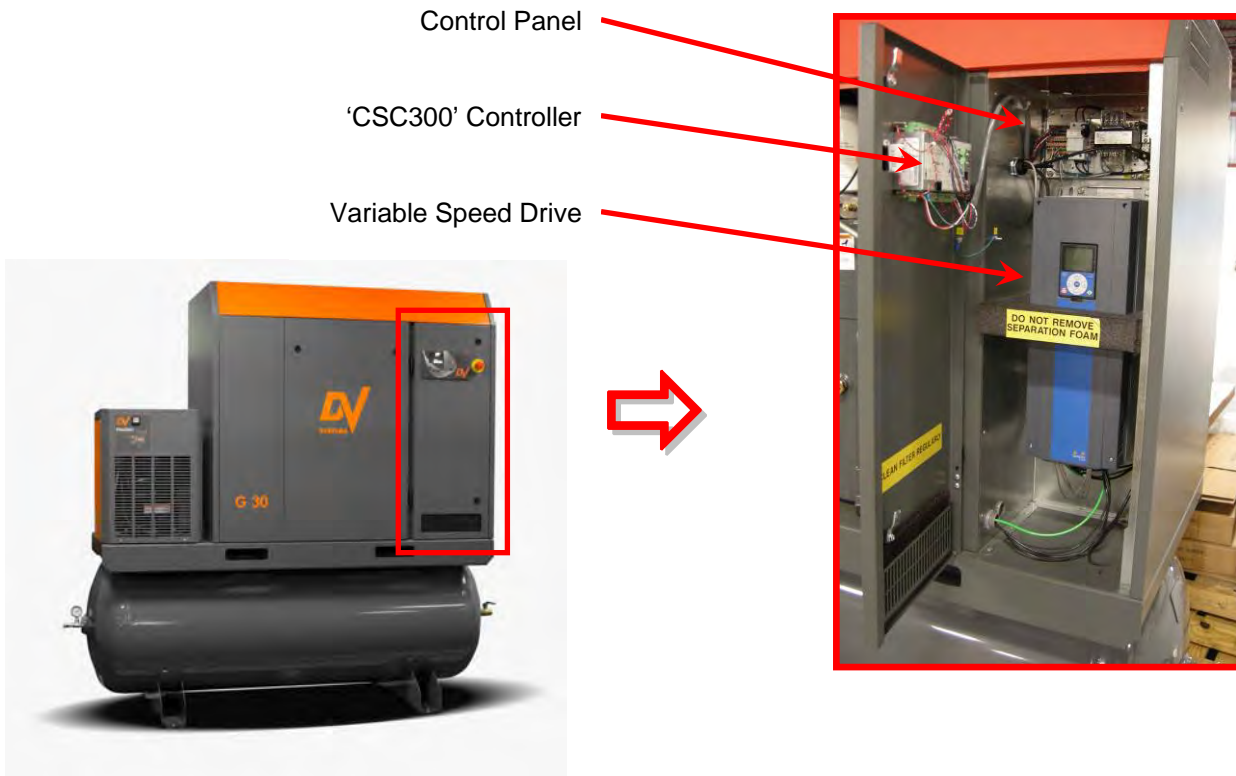

VSD Interface

The VSD Controller Interface is shown at right. It provides a means of operating, monitoring, and adjusting the parameters of the Variable Speed Drive.

Please note that adjustments to the parameters of the Variable Speed Drive should be made only by qualified Technicians, or with the guidance of factory trained personnel. Incorrect adjustments will affect the performance of the Unit, and could result in damage to the Drive.



Variable Speed Drive (cont'd)

Operating Screen

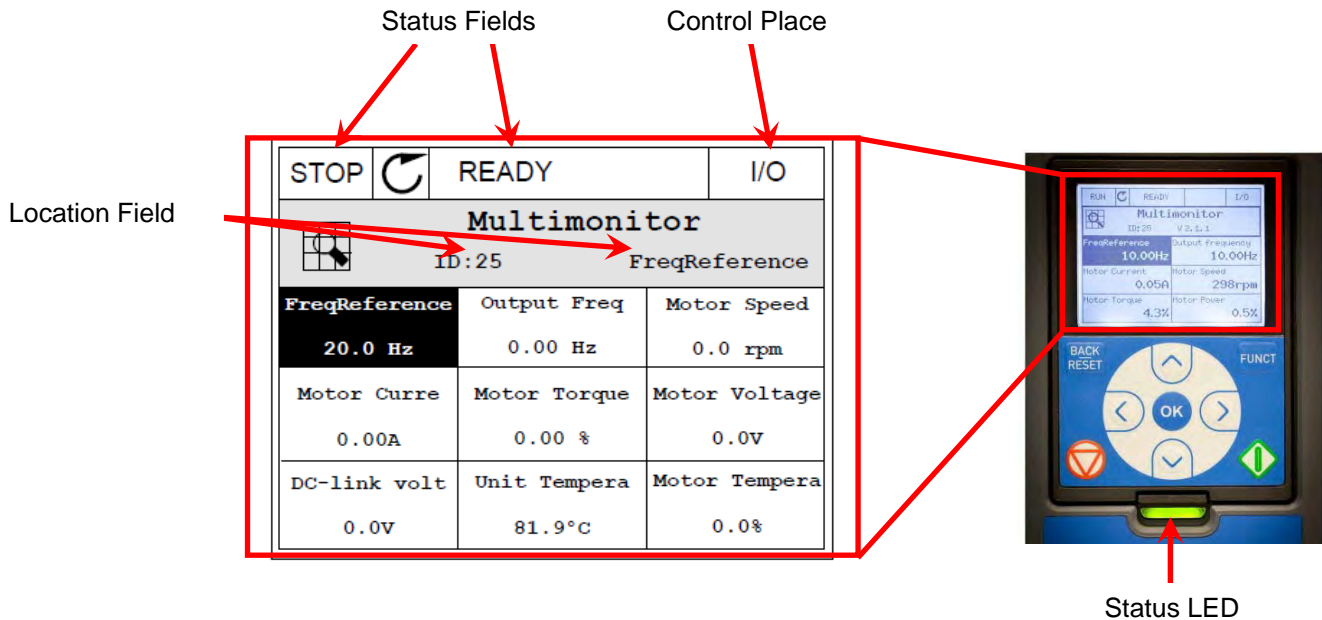

Typical Drive Status Indicators

The Status LED of the drive shows the status of the drive. It can show 5 different statuses.

Color of the LED light	Status of the drive
Blinking slowly	Ready
Green	Run
Red	Fault
Orange	Alarm
Blinking fast	Downloading software

The status of the drive is also indicated on its graphical display.

Status Fields: STOP / RUN and READY / NOT READY / FAULT

Control Place: PC / IO / KEYPAD / FIELDBUS. The default Control Place shall be 'I/O'.

Location Field: the parameter ID number and the current location in the manual.

Default page of the graphical display is set to Multimonitor. On this Multimonitor page, 9 drive status items are displayed.

- Output Frequency: The output frequency to the motor
- Frequency Reference: The frequency reference to motor control. It varies between min. and max. frequency.
- Analogue Input 2: The input speed signal as a percentage of the used range.
- Motor Current: The measured current at the motor leads
- DC Link Voltage: The measured voltage at the drive capacitors.
- Motor Speed: The actual speed of the motor.
- Unit Temperature: The heatsink temperature of the VFD.
- Motor Temperature: The calculated motor temperature in percentage of the nominal working temperature.
- Slot A DIN 1, 2, 3: The status of the digital input 1~ 3.



Variable Speed Drive (cont'd)

Common VSD Fault Codes

Noted below are the most common fault codes that may appear on the VSD. For a more thorough list, please check the manual which deals exclusively with the Vacon Variable Speed Drive and which accompanied the Unit.

Fault Code	Fault	Possible Causes:	Corrective Measures:
1	Over-current.	Current too high in Motor Cable.	Check loading. Check Motor. Check Cables.
2	Over-voltage.	The DC link voltage has exceeded the limits. - too short a deceleration time - high voltage spikes in supply	Make deceleration time longer. Check input voltage.
3	Earth Fault.	Insulation failure in Motor or wiring.	Check Motor wires and Motor.
7	Saturation.	- component failure	Cannot be reset. SWITCH OFF THE POWER and DO NOT RESTART THE DRIVE. Contact distributor.
9	Undervoltage	The DC link voltage is lower than the limits.	Check input voltage.
10	Input phase	- supply voltage malfunction - a defective fuse or malfunction in the supply cables	Check input voltage.
13	AC drive undertemperature	Heatsink temperature is below -10°C.	
14	AC drive overtemperature	Heatsink temperature is over 90°C. Overtemperature warning is issued when the heatsink temperature exceeds 85°C.	Check the amount and flow of cooling air. Check the heatsink for dust. Check the ambient temperature. Ensure the switching frequency is not too high in relation to ambient temperature and motor load
15	Motor stall.	Motor stall protection has tripped.	Check Motor and load.
16	Motor over-temperature.	Motor is overloaded.	Decrease motor load.
17	Motor under-load.	Motor under-load temperature has tripped.	Check load.
32	Fan cooling.	- Fan speed does not match the speed reference. - Fan life time (50,000 h) is reached.	Check drive fan. Contact Distributor.
41	IGBT temperature	The calculated IGBT temperature is too high.	Check loading. Check ambient temperature and amount of cooling air. Check parameter settings.
46	Real Time Clock	The voltage of the RTC battery is low.	Replace the battery.
50	AI low fault	Current at the analogue input is less than 4 mA. - control cable is broken or loose. - signal source has failed.	Check the current loop circuitry.
52	Keypad communication fault.	The data connection between the control keypad and the frequency converter is broken.	Check keypad connection and possible keypad cable.
54	Slot fault.	Defective option board or slot.	Check board and slot. Contact the nearest Distributor.

Separator Filter and Refrigerated Air Dryer

Your Unit may be equipped with a Separator Filter and an 'ASD Series' Refrigerated Air Dryer Unit as indicated below. These items are located in the compressed air lines after the air is compressed but before it enters the Air Receiver. This allows for what is termed a 'dry' Tank.

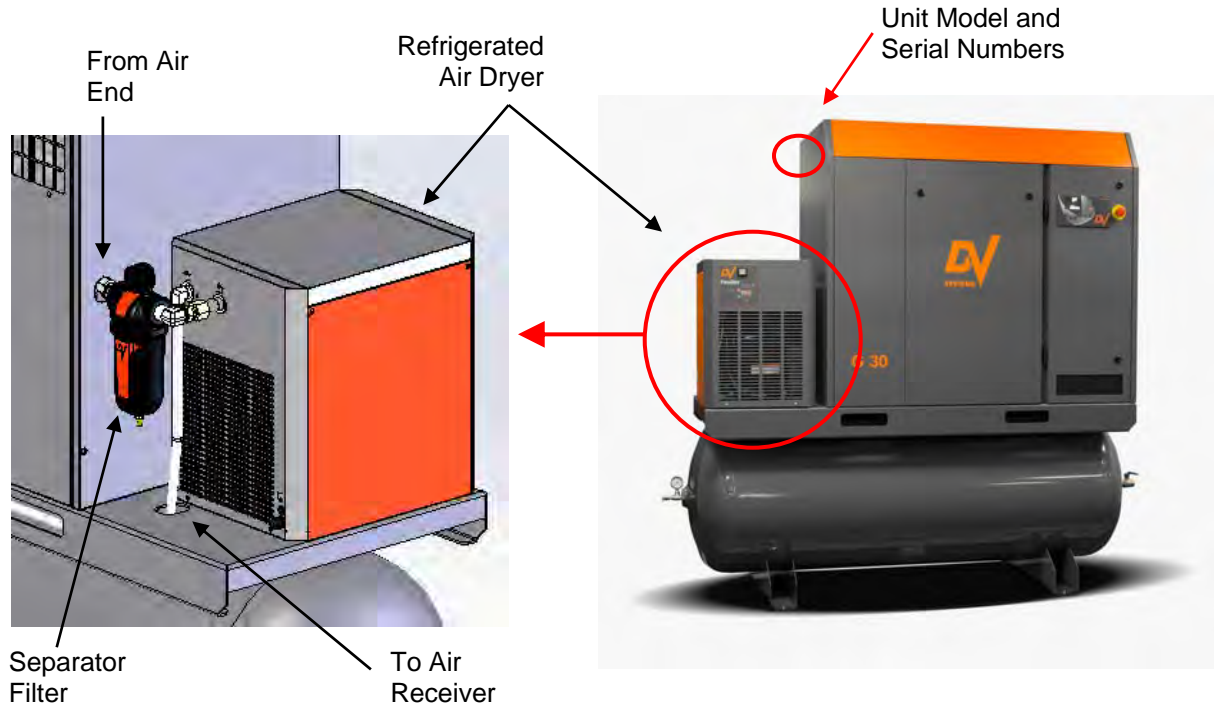

*Drains will discharge automatically under pressure. It is recommended that pneumatic drain tubes be anchored and filtered as per your local municipality regulations.

More detailed information concerning the Dryer Unit is included in the Dryer manual. The information contained in this manual is a 'quick reference' only.

Dryer Controls.

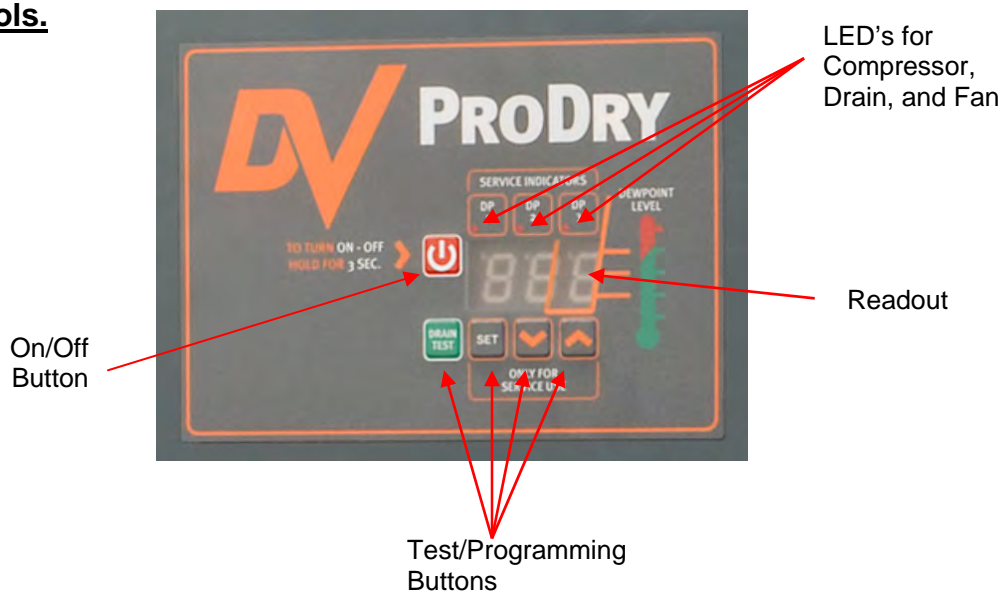

Separator Filter and Refrigerated Air Dryer (cont'd)

Typical Dryer Operation.

The Dryer will operate as follows:

- Pressing the 'On/Off' Button for 3 seconds will start the Unit
- There is a time delay of up to 2 minutes before the Refrigerant Compressor starts.
- The Condenser Fan will start approx. 30 seconds there-after.
- The Fan will not normally run at full speed, this indicated by a flashing LED
- The readout will initially show ambient temperature indicated by 3 horizontal bars on the readout
- Once the Fan and Compressor start, the dew point of the Unit will decrease to approx. 1°C, this indicated by 1 or no horizontal bars.
- Once at approx. 1°C, the Fan will stop, only to be called to run again once the temperature increases to approx. 5°C
- Pressing the 'On/Off' Button (when the Unit is operating) will run the Fan at full speed for several seconds, after which the Unit will stop. (The LED will be on continually while the Fan runs at full speed.)

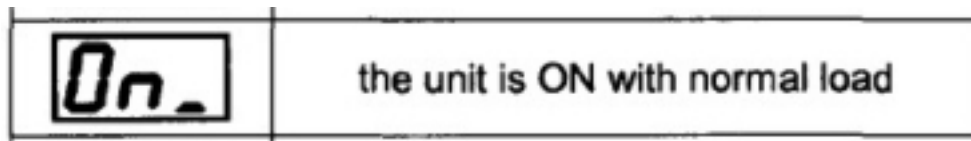

- As well as showing the dew point, the readout may indicate several fault codes as suggested below.

Typical Fault Codes.

The readout will indicate a variety of 'fault codes', the most common being as follows:

ESA

Energy Saving Mode.

- The Dew Point has been running at below -1°C for over 6 minutes.
- The Unit will automatically restart operation at 6°C.

PFI

Temperature Probe Alarm.

- The Temperature Probe is not working properly. It may not be connected to the Board, or the Probe may be defective.
- Replace the Probe if necessary.

HTA

High Temperature Alarm.

- The Dew Point has been running at above 12.5°C for over 6 minutes. The Unit must be manually turned off and on.
- The fault could be caused by a dirty radiator, high ambient temperature, a faulty Fan, or a faulty refrigerant Compressor, to name only a few.

Separator Filter and Refrigerated Air Dryer (cont'd)

Typical Separator Filter.

As previously noted, the Separator Filter is located between the Air End and the Refrigerated Dryer. It contains a 1 micron Separator Element which protects the Dryer Unit by removing liquids and solid particles 1 microns and larger.

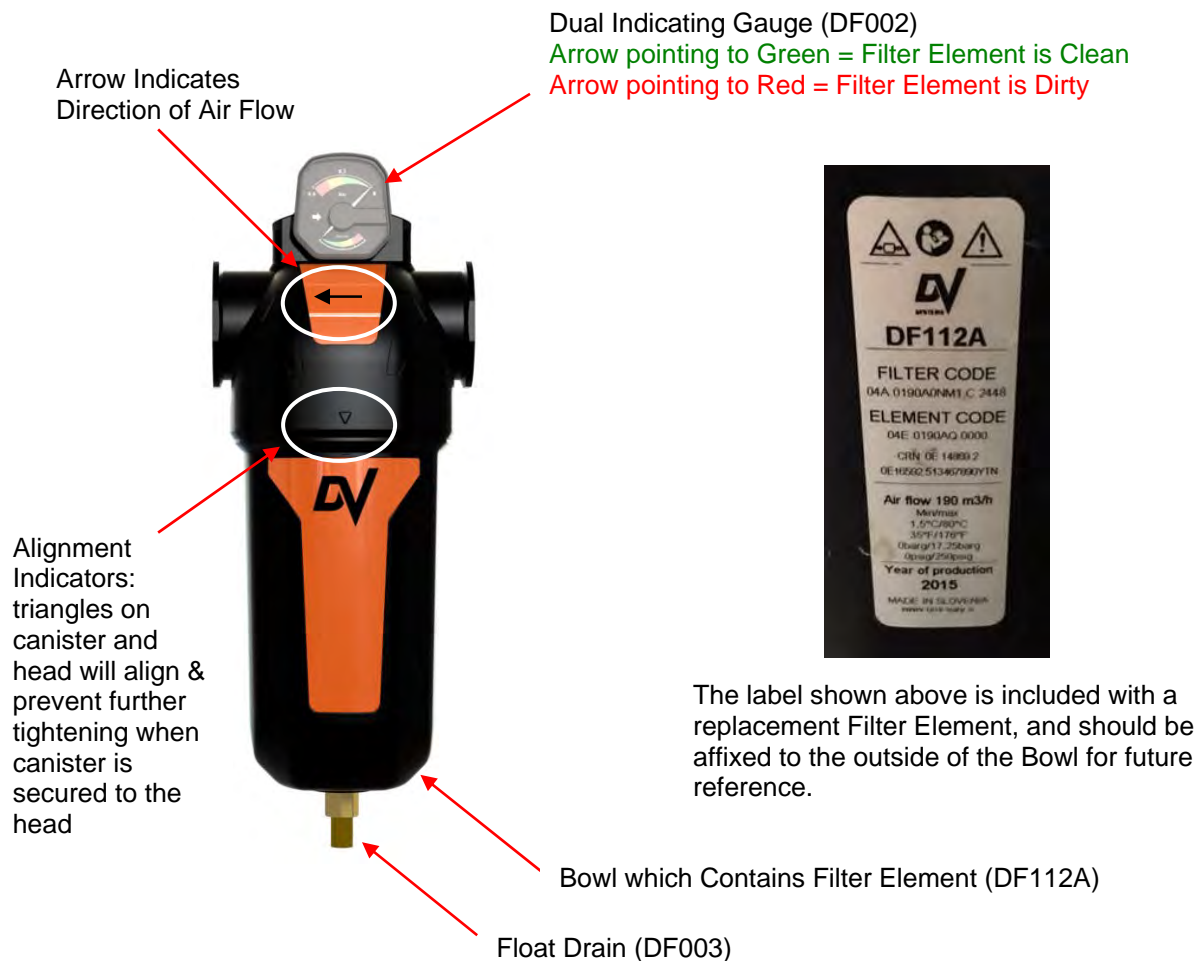

Filter Element Replacement.

To replace a dirty Filter Element:

- Shut the Compressor Unit off.
- Bleed any compressed air from the system to ensure there is no pressure at the Filter.
- Unscrew the Bowl from the assembly, exposing the dirty Filter Element.
- Pull the Filter Element out of the Canister Head
- Clean any debris from the inside of the Bowl
- Remove the O-ring from the inside of the Canister Head
- Install the new O-ring making sure it is properly seated
- Place the new 1 micron Separator Filter Element into the Bowl (the filter is self-centring).
- Screw the Canister with the Element inside it to the Canister Head until the indicators line up.
- Gauge will return to **green** when Filter is once again under pressure.

Trouble Shooting Guide



When servicing the Air Compressor, shut off all power to the Unit, and drain it of air pressure.

The 'Conditions', 'Causes', and 'Suggested Corrections' as indicated below and on the following page(s) are only a guideline for failures that we have found to be most common.

Though this information is provided in this booklet, it is assumed and expected that any personnel involved in the servicing of an Air Compressor Unit is knowledgeable with this type of equipment. Do not attempt to service a Compressor Unit unless you are familiar with it, as there are many issues that may come into play, the most important being personal safety and the welfare of the Unit.

Should you have any questions, or require servicing to your Unit, please contact your local DV Systems Distributor/Service Center.

<u>Condition:</u>	<u>Cause:</u>	<u>Suggested Correction:</u>
A. Unit won't start.	No power to the Unit.	Check that power at the disconnect or breaker is on. Also, check any primary and secondary fuses.
	Loose and/or missing wires in the electrical circuit.	Check that all wiring connections are tight. With a wiring schematic, check that all wiring is present and correct.
	Emergency Stop Button pressed in.	Release by twisting and pulling out.
	Motor Overload is tripped.	Reset the overload.
	Compressor over-heated and stopped.	Insufficient air flow to cool Unit. Ambient temperature too high. Heat Exchanger is dirty. Faulty Temperature Switch. Oil level is low.
	Compressor stopped by over-pressure.	Solenoid Valve faulty. Seals on Intake Valve leaking. Intake Valve Spring broken. Pressure Transducer stopped Unit. Lower maximum pressure setting.
	Unit has 'timed out' / shut off because pressure has not gone below cut-in pressure of 100 psi.	Drop pressure below 100 psi.
Power interruption.	Reset the Unit.	



Trouble Shooting Guide (cont'd)

<u>Condition:</u>	<u>Cause:</u>	<u>Suggested Correction:</u>
B. No or Insufficient Air Flow.	Air Filter is dirty. Oil Separator is blocked. Intake Valve is faulty. Air leaks in the system. Pressure limits are incorrectly set. Blowdown Solenoid Valve is open. Belt are broken or slipping	Replace the Air Filter. Replace the Oil Separator. Repair or replace the Intake Valve. Check the Unit and system for air leaks. Adjust the pressure settings. Check the wiring to the Solenoid and replace as necessary. Check Belt tension and that Belts are in good condition.
C. Unit is overheating.	Ambient temperature is too high. Blocked air circulation at the Unit. Heat Exchanger is dirty. Oil level is too low. Using wrong type of compressor oil. Thermo Valve is faulty. Oil Filter is blocked. Temperature Sensor is faulty. Thermostat is faulty. Pressure is too high. Cabinet door/panel is open/off.	Check cooling air circulation. Check the air circulation in and around the Unit. Clean the Heat Exchanger Add oil as required. Change to the factory recommended oil. Check and repair as necessary. Replace the Oil Filter. Check the wiring to the Temperature sensor. Replace the Sensor if necessary. Replace the Thermostat. Lower the pressure setting. Secure the door/panel to the Unit.
D. Compressor Starts Slowly.	Intake Valve not functioning properly. Ambient temperature is too low. Minimum Pressure Valve leaking back to Air End. Minimum Pressure Valve setting is too high. Using wrong type of oil.	Check Intake Valve operation. Repair or replace as required. Stop and restart once ambient increases. Repair or replace the Minimum Pressure Valve. Adjust Minimum Pressure Valve setting to 65 psi. Change to factory recommended oil.



Trouble Shooting Guide (cont'd)

<u>Condition:</u>	<u>Cause:</u>	<u>Suggested Correction:</u>
E. Intake Valve Leaks Oil When Unit Stops.	<p>Intake Valve Seal leaks.</p> <p>Intake Valve stuck in open position.</p> <p>Blowdown Solenoid not functioning.</p>	<p>Repair using an Intake Valve Repair Kit.</p> <p>Repair or replace the Intake Valve.</p> <p>Replace the Solenoid.</p>
F. Oil Consumption is Too High.	<p>Oil level is too high.</p> <p>Oil Return Line (Scavenge Line) is blocked.</p> <p>Oil Separator is saturated with oil.</p> <p>Wrong type of oil used.</p> <p>Unit is operating at too high a temperature.</p> <p>Oil leak.</p> <p>Unit load is light or excessive load/idle cycles.</p>	<p>Reduce the oil level to the proper level.</p> <p>Clean and/or replace the Scavenge In-Line Filter.</p> <p>Replace the Oil Separator.</p> <p>Change to factory recommended oil.</p> <p>See 'Section C'.</p> <p>Repair oil leak.</p> <p>Ensure Unit is set to operate at correct pressures, and there is a <u>minimum</u> of 10 psi differential. Also the Unit could be oversized for the tank capacity.</p>
G. Compressor Surges.	<p>Restriction in Heat Exchanger or Hoses.</p> <p>Pressure Transducer setting is incorrect or malfunctioning.</p> <p>Blockage at Unit outlet.</p> <p>Dryer is freezing up, not allowing air to pass through.</p> <p>Air Receiver is too small.</p>	<p>Flush out or replace.</p> <p>Set pressure as per instructions or replace.</p> <p>Check for obstructions in outlet piping.</p> <p>Check that the Dryer parameters are correct. Increase dew point to 2.0 if required.</p> <p>Use a <u>minimum</u> 120 Gallon Tank.</p>
H. High Power Consumption.	<p>Improper air pressure settings.</p> <p>Blowdown Solenoid is not functioning.</p> <p>The voltage in the building is too low or there is a phase imbalance.</p> <p>The Motor is failing.</p>	<p>Reset the pressure as per factory defaults.</p> <p>Inspect or replace as necessary.</p> <p>Contact an Electrician to verify.</p> <p>Have Motor inspected.</p>
I Fault Alarms.	<p>Emergency Stop.</p> <p>High Temperature.</p> <p>Low Temperature.</p> <p>High pressure.</p>	<p>Ensure Emergency Stop Button is not pressed in.</p> <p>See 'Section C'.</p> <p>Ambient temperature is too low. Increase to 10°C.</p> <p>Check the pressure settings, the Pressure Transducer and the wiring to the Transducer.</p>



Limited Warranty : G Series Screw Compressors

The manufacturer warrants the product manufactured by it and sold to the original purchaser, when properly installed, operated, applied, and maintained in accordance with procedures and recommendations outlined in the manufacturer's instruction manuals, to be free of defects in material and workmanship for a period of one (1) year from the date of installation, not to exceed eighteen (18) months from the date of manufacture, provided such defect is discovered and brought to the manufacturer's attention within the aforesaid warranty period, conditional upon the following:

- 1) Genuine 'DEV-3000' Lubricant and Parts are used for the full warranty period.
- 2) The Unit is maintained in accordance with the manufacturer's instruction manual for the Unit, with the following minimum maintenance requirements:
 - A) Complete Oil change every 8000 hours (not to exceed 12 months) from the date of initial start-up using 'DEV-3000' Lubricant. When operating in adverse conditions, Oil changes must be done more frequently.
 - B) Oil Filter must be changed every 4000 hours (not to exceed 6 months) from the date of initial start-up using the appropriate DV Systems part. When operating in adverse conditions, Oil Filter changes must be done more frequently.
 - C) Air Intake Filter must be changed every 2000 hours (not to exceed 6 months) from the initial date of start-up using the appropriate DV Systems part. When operating in adverse conditions, Air Intake Filter changes must be done more frequently.
 - D) Air/Oil Separator Filter must be changed every 8000 hours (not to exceed 12 months) from the date of initial start-up using the appropriate DV Systems part. When operating in adverse conditions, Air/Oil Separator changes must be done more frequently.
 - E) Appropriate and complete maintenance records must be kept by the End User. As well, the End User must retain copies of invoices indicating the timely purchase of the DV Systems Compressor Oil and maintenance/service parts. All records and invoices must be kept for the duration of the manufacturer's warranty period.
- 3) Disclaimer:
 - A) The following items are considered normal wear items, and are warranted for a period of one (1) year from the date of installation, not to exceed eighteen (18) months from the date of manufacture; the Shaft Seal on the Air End Drive Shaft, the Intake Valve Assembly (and its components), and the Minimum Pressure Valve.
 - B) All electrical components are warranted for a period of one (1) year from the date of installation, not to exceed eighteen (18) months from the date of manufacture.

An additional four (4) year extended Air End Warranty and a four (4) year extended Three Phase Baldor Motor Warranty are available on those Units that:

- A) have been registered with the manufacturer within thirty (30) days from the date of purchase, this done by returning the 'DV Systems Rotary Screw Compressor Start-Up Sheet' and
- B) have been maintained in accordance with the manufacturer's instruction manual as noted in '2' above.

The manufacturer will repair or replace any product or part determined to be defective by the manufacturer within the warranty period, provided such defect occurred in normal service and is not the result of misapplication, misuse, abuse, neglect, incorrect maintenance, accident, or normal wear. Normal maintenance items requiring routine replacement are not warranted. Please refer to the appropriate service bulletin to determine normal maintenance requirements.

The warranty covers parts and labour for the warranty period (excluding the Three Phase Baldor Motors. Labour is not covered in the (4) year extended Baldor Motor Warranty.) Either repair or replacement shall be at the sole option of the manufacturer. Any service performed on the product by anyone other than the manufacturer must first be authorized by the manufacturer. Unauthorized service voids the warranty and any resulting charge or subsequent claim will not be paid.

Products repaired or replaced under warranty shall be warranted for the unexpired portion of the warranty applying to the original product, based on the original date of invoice as outlined above.

There is no other expressed warranty. Implied warranties including those of merchantability and fitness for a particular purpose are limited to one (1) year from the date of invoice to the extent permitted by law and any and all implied warranties are excluded. This is the exclusive remedy. Liability for consequential damages under any and all warranties are excluded to the extent exclusion is permitted by law.

This warranty gives you specific rights, and you may also have other rights within your jurisdiction.

This warranty does not cover:

- 1) Merchandise that has become inoperative because of ordinary wear, misuse, neglect, accident, or improper and unauthorized repair or alteration.
- 2) Electric Motors manufactured and identified as the product of another company.
- 3) Compressor Units that have not been properly maintained in accordance with the recommended maintenance and lubrication change procedures and/or that have been subject to inordinate use through being inadequately sized or poorly installed.
- 4) Compressor Units using other than the recommended lubricant.
- 5) Costs occasioned by the removal, replacement, or repair of merchandise (other than by DV Systems) without previous authorization from DV Systems.
- 6) Expenses incurred in travel or lodging beyond a 100 kilometre (60 mile) distance from the nearest DV Systems Authorized Service Centre.
- 7) Expenses incurred in the return of equipment for inspection purposes to the manufacturer's facility. All returns must be pre-authorized, returned 'Freight Prepaid', and accompanied by a 'Return Material Authorization (RMA) Number' (obtainable through DV Systems).
- 8) Products, parts, materials, components, or accessories manufactured by others or supplied in connection with the sale of the manufacturer's products.
- 9) Repair and transportation costs of merchandise determined not to be defective under the terms and conditions of this warranty.
- 10) The cost of rental or loaner equipment while the customer's original equipment is being assessed, repaired, or replaced.
- 11) Consequential damages in the event of product failure.

All decisions by DV Systems Inc. with regard to this policy shall be final. DV Systems will not be responsible for any claimed defective materials returned other than in accordance with this statement of policy or without our prior authorization.

DV Systems Inc. (Canada)
490 Welham Road
Barrie, Ontario, L4N 8Z4, Canada
Tel: (705) 728-5657
Fax: (705) 728-4974

DV Systems, Ltd. (USA)
128-B Talbert Road
Mooresville, NC, 28117, USA
Tel: (704) 799-0046
Fax: (704) 799-0355

MODEL NO.	HP	PRESSURE PSI	SCFM @ MAX. PRESSURE	NOMINAL SOUND @ 1 METRE	MOTOR NAMEPLATE AMP				WEIGHT LBS
					3-PHASE				
					200V	230V	460V	575V	
G20	20	100-120	82	67 dBA	53	46	23	18.4	1120
		125-145	73						
G25	25	100-120	100	68 dBA	65	56	28	22.7	1120
		125-145	91						
G30	30	100-120	116	69 dBA	78	68	34	27	1120
		125-145	106						

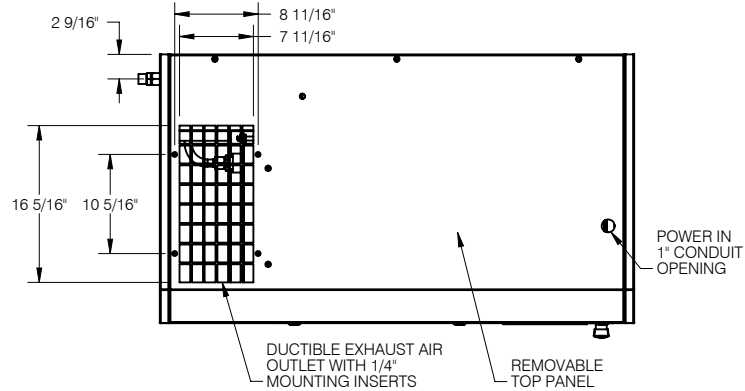

INSTALLATION REQUIREMENTS

1. MAINTAIN 3 FEET DISTANCE FROM WALLS AND OTHER OBJECTS FOR PURPOSE OF COOLING AND SERVICING
2. COMPRESSOR MUST BE LEVEL AND ANCHORED DOWN TO SOLID LEVEL FLOOR.
3. AMBIENT CONDITIONS:
10°C (50°F) MIN. 40°C (104°F) MAX.
4. APPROACH TEMP. FROM TANK 5°C (41°F).

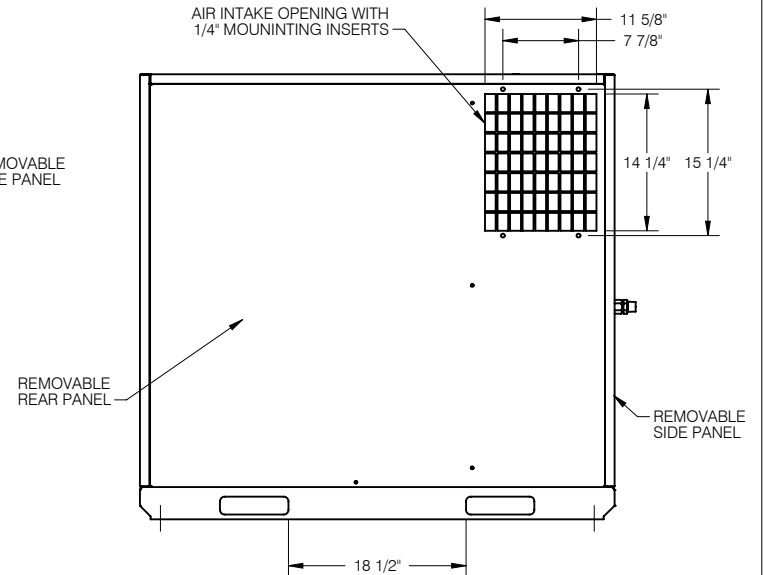
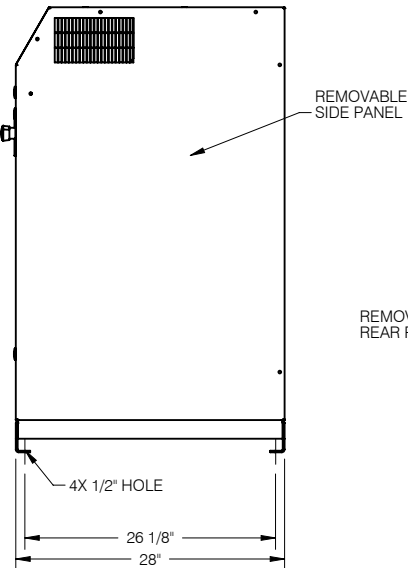
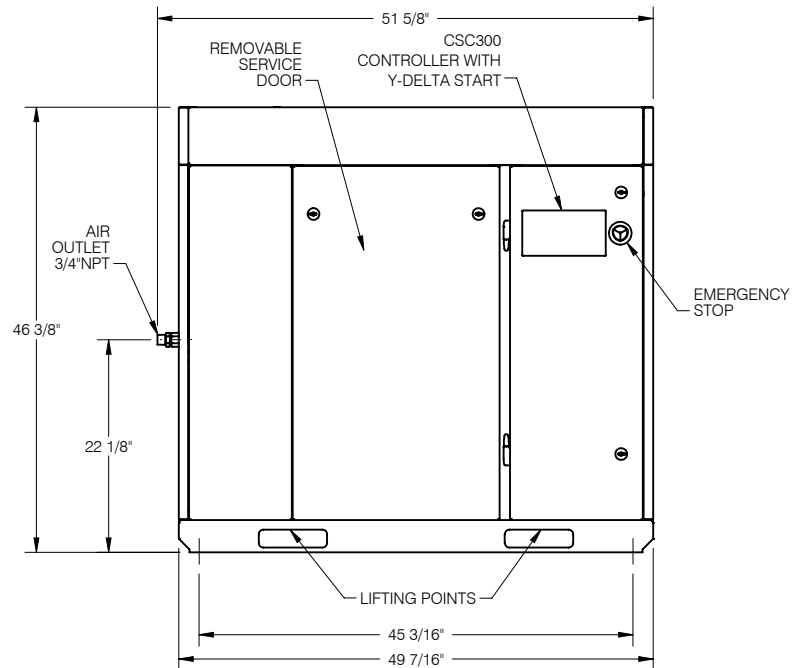

IMPORTANT NOTE: This print is the confidential property of DV SYSTEMS, INC. It is not to be used or reproduced in any manner, nor submitted to other parties for examination without the prior approval of DV SYSTEMS, INC. DV SYSTEMS, INC. is continually trying to improve its products, specifications subject to change without notice.



NAME OF PROJECT				DESCRIPTION OF DRAWING	
G20-30 SCREW COMPRESSOR				SALES-ENGINEERING DRAWING	
DRAWN BY	CHECKED BY	DATE	SCALE	DRAWING NO.	SHT NO/REV.
LT		2/13/17	N.T.S	G20 G25 G30	

MODEL NO.	HP	PRESSURE PSI	SCFM @ MAX. PRESSURE	NOMINAL SOUND @ 1 METRE	MOTOR NAMEPLATE AMP				AIR RECEIVER GAL.	DRYER	FILTER ELEMENT	WEIGHT LBS
					3-PHASE							
					200V	230V	460V	575V				
G20TD	20	100-120	82	67 dBA	53	46	23	18.4	120	ASD-100 115V, 60Hz, 11.6A	1 MICRON	1683
		125-145	73									
G25TD	25	100-120	100	68 dBA	65	56	28	22.7	120	ASD-100 115V, 60Hz, 11.6A	1 MICRON	1683
		125-145	91									
G30TD	30	100-120	116	69 dBA	78	68	34	27	120	ASD-100 115V, 60Hz, 11.6A	1 MICRON	1683
		125-145	106									

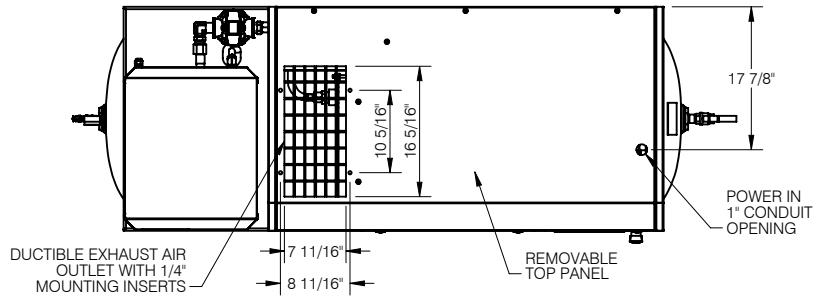

INSTALLATION REQUIREMENTS

1. MAINTAIN 3 FEET DISTANCE FROM WALLS AND OTHER OBJECTS FOR PURPOSE OF COOLING AND SERVICING
2. COMPRESSOR MUST BE LEVEL AND ANCHORED DOWN TO SOLID LEVEL FLOOR.
3. AMBIENT CONDITIONS:
10°C (50°F) MIN. 40°C (104°F) MAX.
4. APPROACH TEMP. FROM TANK 5°C (41°F).

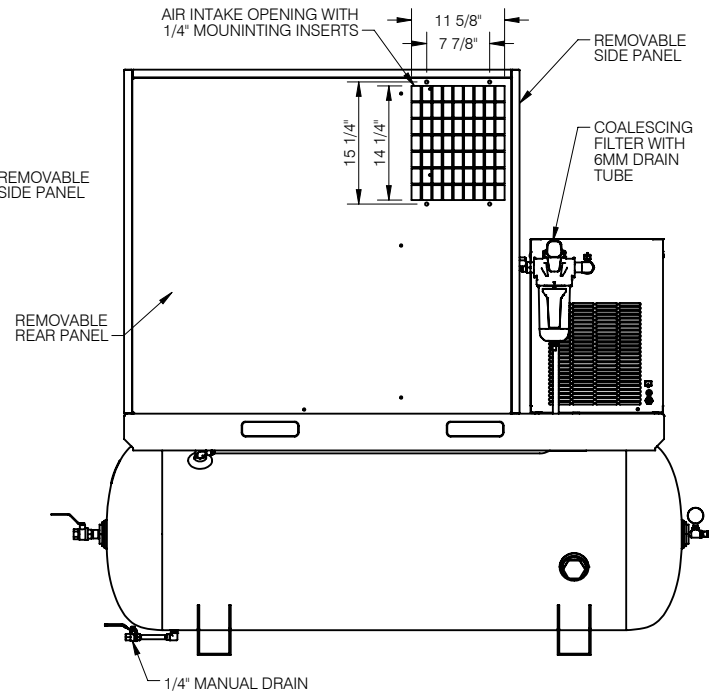
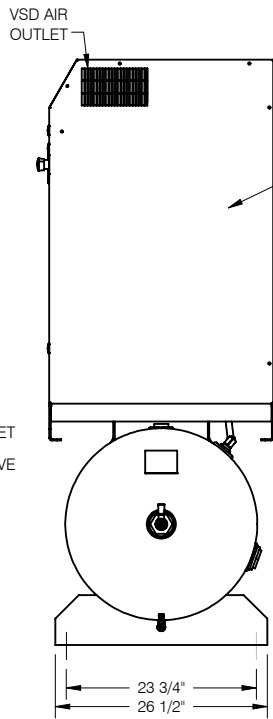
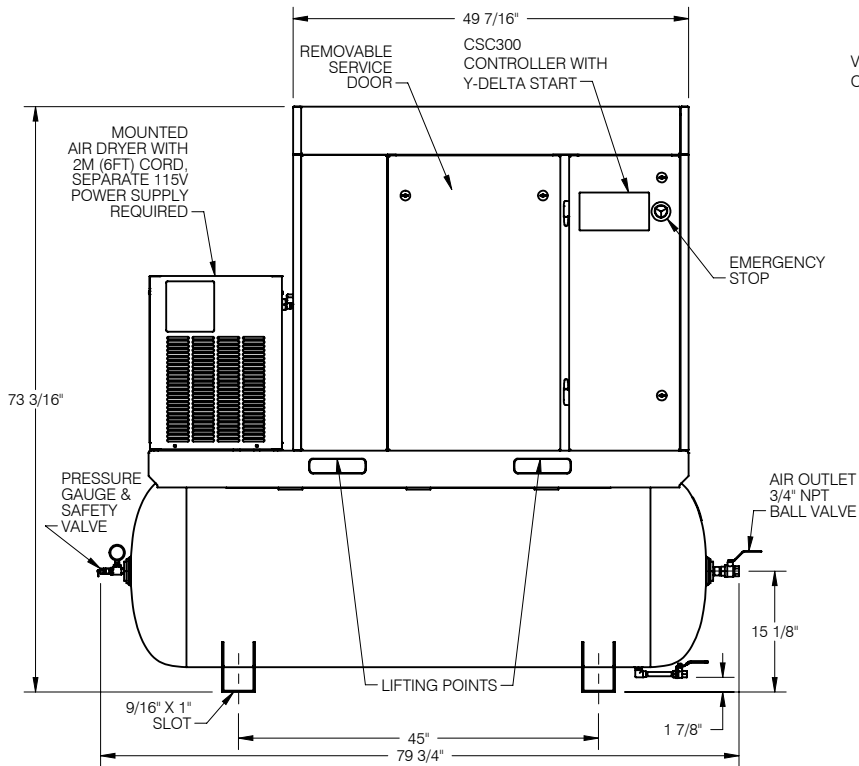

IMPORTANT NOTE: This print is the confidential property of DV SYSTEMS, INC. It is not to be used or reproduced in any manner, nor submitted to other parties for examination without the prior approval of DV SYSTEMS, INC. DV SYSTEMS, INC. is continually trying to improve its products, specifications subject to change without notice.



NAME OF PROJECT				DESCRIPTION OF DRAWING	
G20-30TD SCREW COMPRESSOR WITH DRYER				SALES-ENGINEERING DRAWING	
DRAWN BY	CHECKED BY	DATE	SCALE	DRAWING NO.	SHT NO/REV.
LT		1/05/17	N.T.S	G20TD G25TD G30TD	

MODEL NO.	HP	PRESSURE PSI	SCFM @ 120, 145 PSI			NOMINAL SOUND @ 1 METRE	MOTOR NAMEPLATE VOLTAGE*				WEIGHT LBS
			100% CAP.	70% CAP.	40% CAP.		3-PHASE				
			200V	230V	460V		575V				
G25VSD	25	110-120	100	70	40	68 dBA	65	56	28	22.7	1195
		135-145	96	67	38						
G30VSD	30	110-120	116	81	46	69 dBA	78	68	34	27	1195
		135-145	112	78	45						

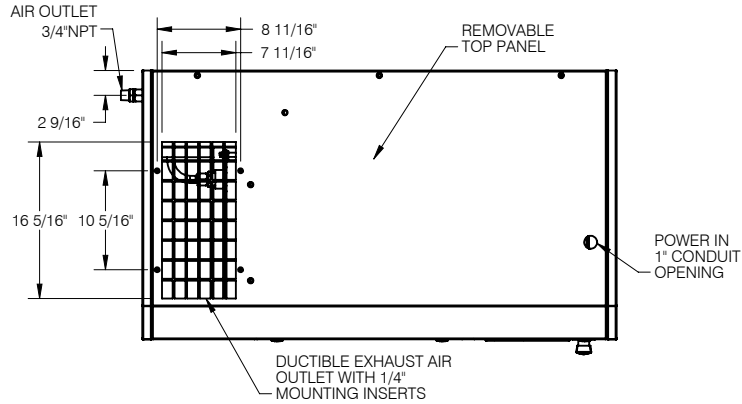

VOLTAGE	PHASE	FUSE TYPE	FUSE AMP	
			25 HP	30 HP
200	3	J FAST-ACTING (DFJ/HSJ)	80	110
230			70	80
460			35	40
575			35	35

*MOTOR AMP IS 100% OF FULL LOAD, @70% & 40% THE AMP WILL DECREASE PROPORTIONALLY

INSTALLATION REQUIREMENTS

1. MAINTAIN 3 FEET DISTANCE FROM WALLS AND OTHER OBJECTS FOR PURPOSE OF COOLING AND SERVICING
2. COMPRESSOR MUST BE LEVEL AND ANCHORED DOWN TO SOLID LEVEL FLOOR.
3. AMBIENT CONDITIONS: 10°C (50°F) MIN. 40°C (104°F) MAX.
4. APPROACH TEMP. FROM TANK 5°C (41°F).

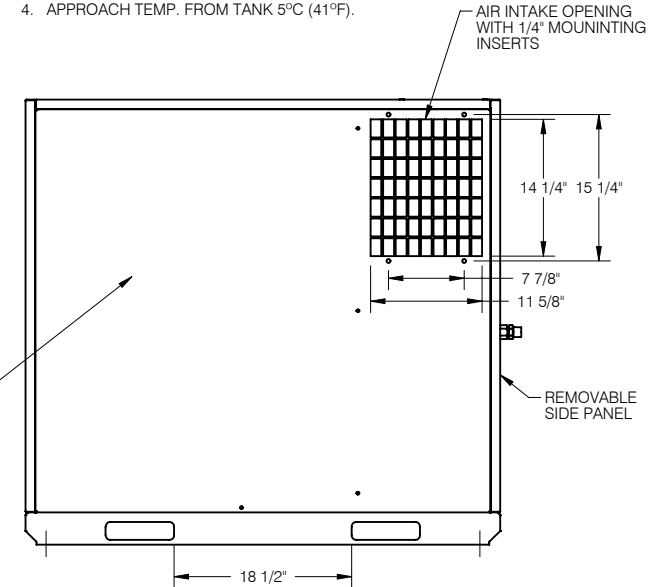
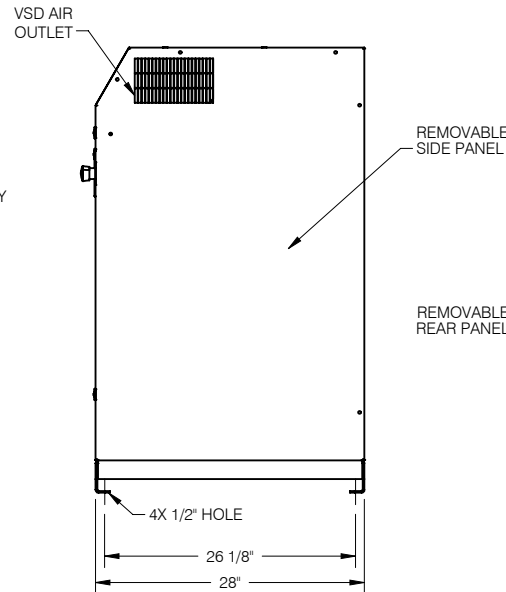
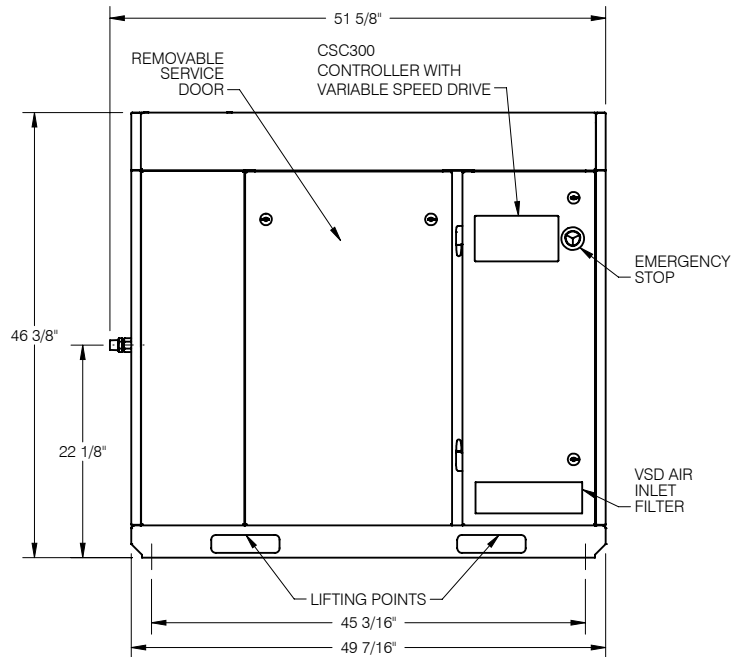

IMPORTANT NOTE: This print is the confidential property of DV SYSTEMS, INC. It is not to be used or reproduced in any manner, nor submitted to other parties for examination without the prior approval of DV SYSTEMS, INC. DV SYSTEMS, INC. is continually trying to improve its products, specifications subject to change without notice.



NAME OF PROJECT				DESCRIPTION OF DRAWING		
G25-30VSD SCREW COMPRESSOR				SALES-ENGINEERING DRAWING		
DRAWN BY	CHECKED BY	DATE	SCALE	DRAWING NO.	SHT NO	REV.
LT		2/13/17	N.T.S	G25VSD G30VSD		

MODEL NO.	HP	PRESSURE PSI	SCFM @ 120, 145 PSI			NOMINAL SOUND @ 1 METRE	MOTOR NAMEPLATE VOLTAGE*				AIR RECEIVER GAL.	DRYER	FILTER ELEMENT	WEIGHT LBS
			100% CAP.	70% CAP.	40% CAP.		3-PHASE							
			200V	230V	460V		575V							
G25TDVSD	25	110-120	100	70	40	68 dBA	65	56	28	22.7	120	ASD-100 115V, 60Hz, 11.6A	1 MICRON	1758
		135-145	96	67	38									
G30TDVSD	30	110-120	116	81	46	69 dBA	78	68	34	27	120	ASD-100 115V, 60Hz, 11.6A	1 MICRON	1758
		135-145	112	78	45									

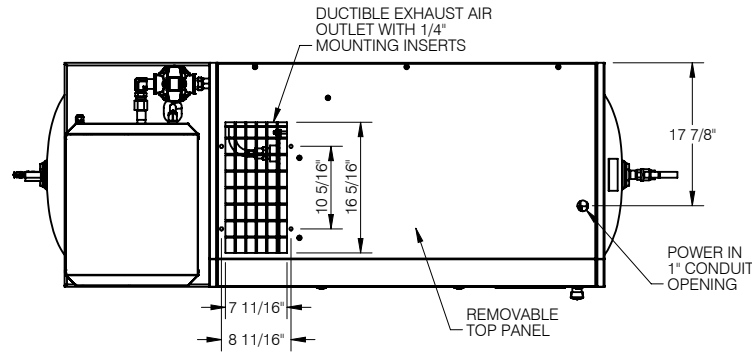

VOLTAGE	PHASE	FUSE TYPE	FUSE AMP	
			25 HP	30 HP
200	3	J FAST-ACTING (DFJ/HSJ)	80	110
230			70	80
460			35	40
575			35	35

*MOTOR AMP IS 100% OF FULL LOAD, @70% & 40% THE AMP WILL DECREASE PROPORTIONALLY

INSTALLATION REQUIREMENTS

1. MAINTAIN 3 FEET DISTANCE FROM WALLS AND OTHER OBJECTS FOR PURPOSE OF COOLING AND SERVICING
2. COMPRESSOR MUST BE LEVEL AND ANCHORED DOWN TO SOLID LEVEL FLOOR.
3. AMBIENT CONDITIONS: 10°C (50°F) MIN. 40°C (104°F) MAX.
4. APPROACH TEMP. FROM TANK 5°C (41°F).

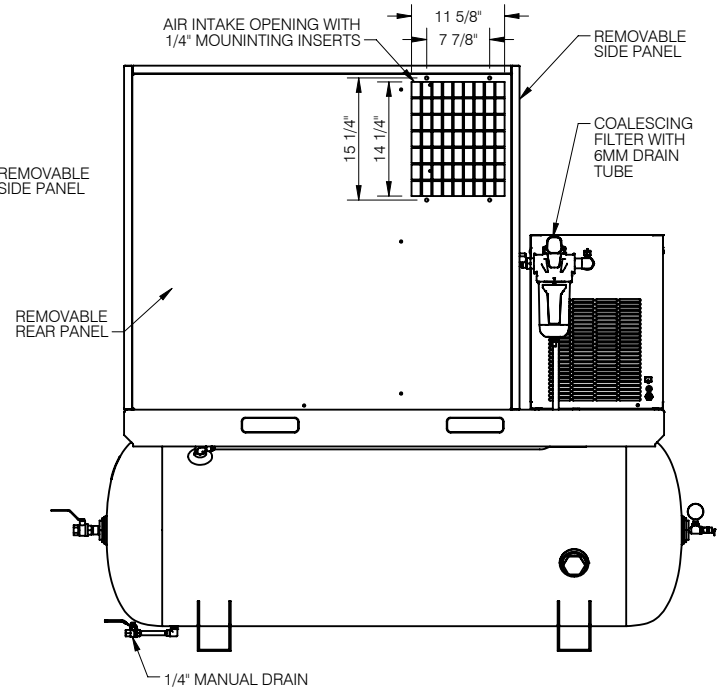
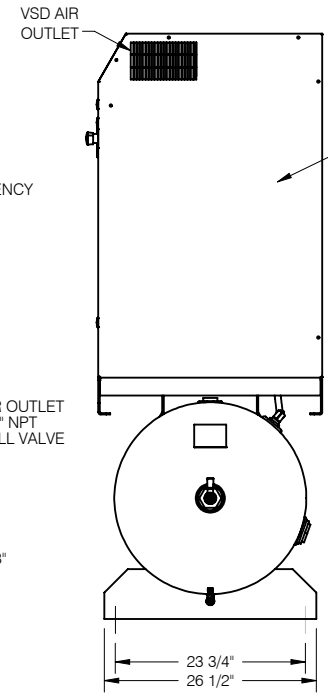
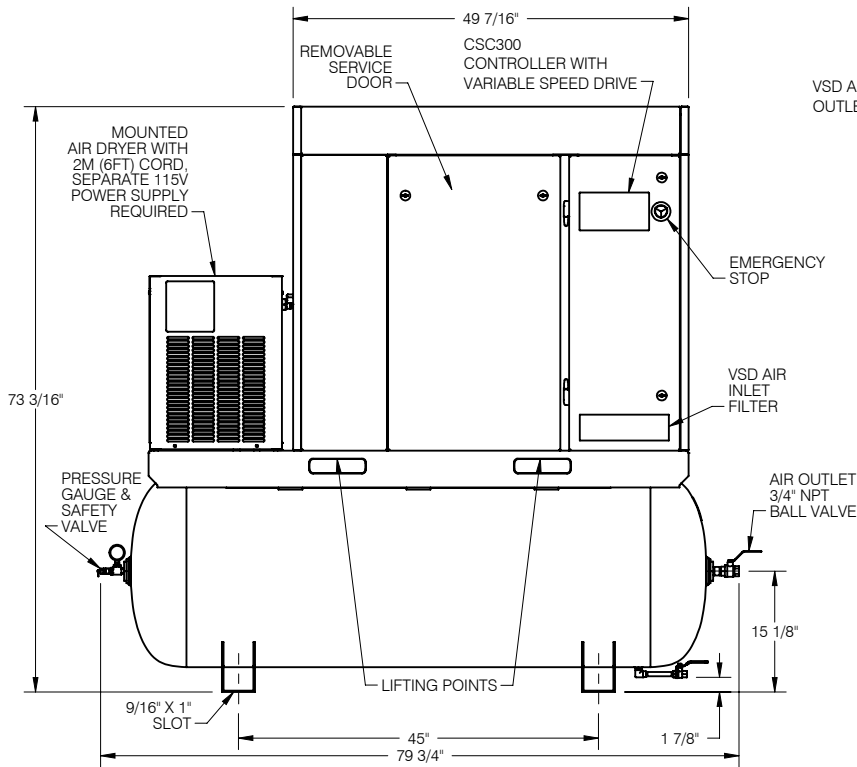

IMPORTANT NOTE: This print is the confidential property of DV SYSTEMS, INC. It is not to be used or reproduced in any manner, nor submitted to other parties for examination without the prior approval of DV SYSTEMS, INC. DV SYSTEMS, INC. is continually trying to improve its products, specifications subject to change without notice.



NAME OF PROJECT				DESCRIPTION OF DRAWING	
G25-30TDVSD SCREW COMPRESSOR WITH DRYER				SALES-ENGINEERING DRAWING	
DRAWN BY	CHECKED BY	DATE	SCALE	DRAWING NO.	SHT NO/REV.
LT		1/05/17	N.T.S	G25TDVSD G30TDVSD	

ITEM NO.	PART NUMBER	DESCRIPTION	QTY.
1	DSC-002961	INVERTER G25-200V, G30-230V	1
	DSC-002962	INVERTER G30-200V	
	DSC-002963	INVERTER G30-460V	
	DSC-002964	INVERTER G25-575V, G30-575V	
	DSC-002965	INVERTER G25-230V INVERTER G25-460	
2	SS-13	5/16-18 X 7/8 HHCS	4
3	SS-1503	5/16" LOCKWASHER	8
4	SS-02002	5/16-18 THREADED INSERT	4
5	SS-1524	5/16" FLAT WASHER	6
6	DSC-001158	BELT G20 120PSI	4
	DSC-001159	BELT G25	
	DSC-001160	BELT G30	
	DSC-001417	BELT G20 145PSI	
7	DSC-001669	AIR END BUSHING G20, G30	1
	DSC-001670	AIR END BUSHING G25	
8	PU-9253	AIR END PULLEY G20 120PSI, G30 120 PSI	1
	PU-9254	AIR END PULLEY G25	
	PU-9256	AIR END PULLEY G20 145PSI, G30 145PSI	
9	DSC-001155	MOTOR BUSHING G25, G30	1
	DSC-001396	MOTOR BUHSING G20	
10	PU-9254	MOTOR PULLEY G20	1
	PU-9255	MOTOR PULLEY G25 120PSI, G30	
	PU-9257	MOTOR PULLEY G25 145PSI	

ITEM NO.	PART NUMBER	DESCRIPTION	QTY.
11	SS-45	1/2-13 X 1.125" HHCS	4
12	SS-1506	1/2" MEDIUM LOCKWASHER	10
13	ACC-9079	VIBRATION ISOLATOR	4
14	DSC-002927	MOTOR-AIR END FRAME	1
15	SS-73	1/2-13 X 1.125" HHCS	4
16	SS-81	5/8-11 X 1-3/4 HEX BOLT GR.5	4
17	SS-1508	5/8" MEDIUM LOCKWASHER	8
18	SS-1529	5/8" FLAT WASHER	4
19	MH-9078	MOTOR HARNESS G20-25-200V, G30-200V	1
	MH-9079	MOTOR HARNESS G20-230V	
	MH-9080	MOTOR HARNESS G20-460V	
	MH-9081	MOTOR HARNESS G20, G25-575V	
	MH-9082	MOTOR HARNESS G25-230V, G30-200V	
	MH-9083	MOTOR HARNESS G25-460V	
	MH-9084	MOTOR HARNESS G30-460V	
	MH-9085	MOTOR HARNESS G30-575V	
	MH-9086	MTR HARN. G25VSD-200V, G25-30VSD-230V	
	MH-9087	MTR HARNESS G25-30VSD-460V	
MH-9088	MOTOR HARNESS G25,30VSD-575V		
20	DSC-001142	M16-2.0 X 30MM GR12.9 SHCS	4
21	DSC-001110	AIR END PLATE	1
22	SS-33	3/8-16" X 4" HHCS	1

ITEM NO.	PART NUMBER	DESCRIPTION	QTY.
23	SS-1502	3/8" LOCKWASHER	2
24	SS-657	3/8-16 HEX NUT	2
25	DSC-001111	AIR END MOUNTING BAR	2
26	DSC-614	SHAFT KEY G-SERIES AIR END	1
27	DSC-001186	AIR END G-SERIES	1
28	MO-9300	MOTOR 20HP 200/60/3	1
	MO-9301	MOTOR 20HP 230-460/60/3	
	MO-9302	MOTOR 20HP 575/60/3	
	MO-9267	MOTOR 25HP 200/60/3	
	MO-9268	MOTOR 25HP 230-460/60/3	
	MO-9269	MOTOR 25HP 575/60/3	
	MO-9270	MOTOR 30HP 200/60/3	
MO-9271	MOTOR 30HP 230-460/60/3		
MO-9272	MOTOR 30HP 575/60/3		
29	DSC-002895	MOTOR ISOLATOR STUD	2
30	SS-50	1/2-13 x 1.5" HHCS	2
31	DSC-657	FAN & BUSHING ASSEMBLY G20	1
	DSC-001151	FAN & BUSHING ASSEMBLY G25-30	
32	SS-11	5/16-18 X 1/2 HHCS	4
33	DSC-002930	FAN SHROUD	1
34	DSC-002255	FAN SHROUD GASKET	1

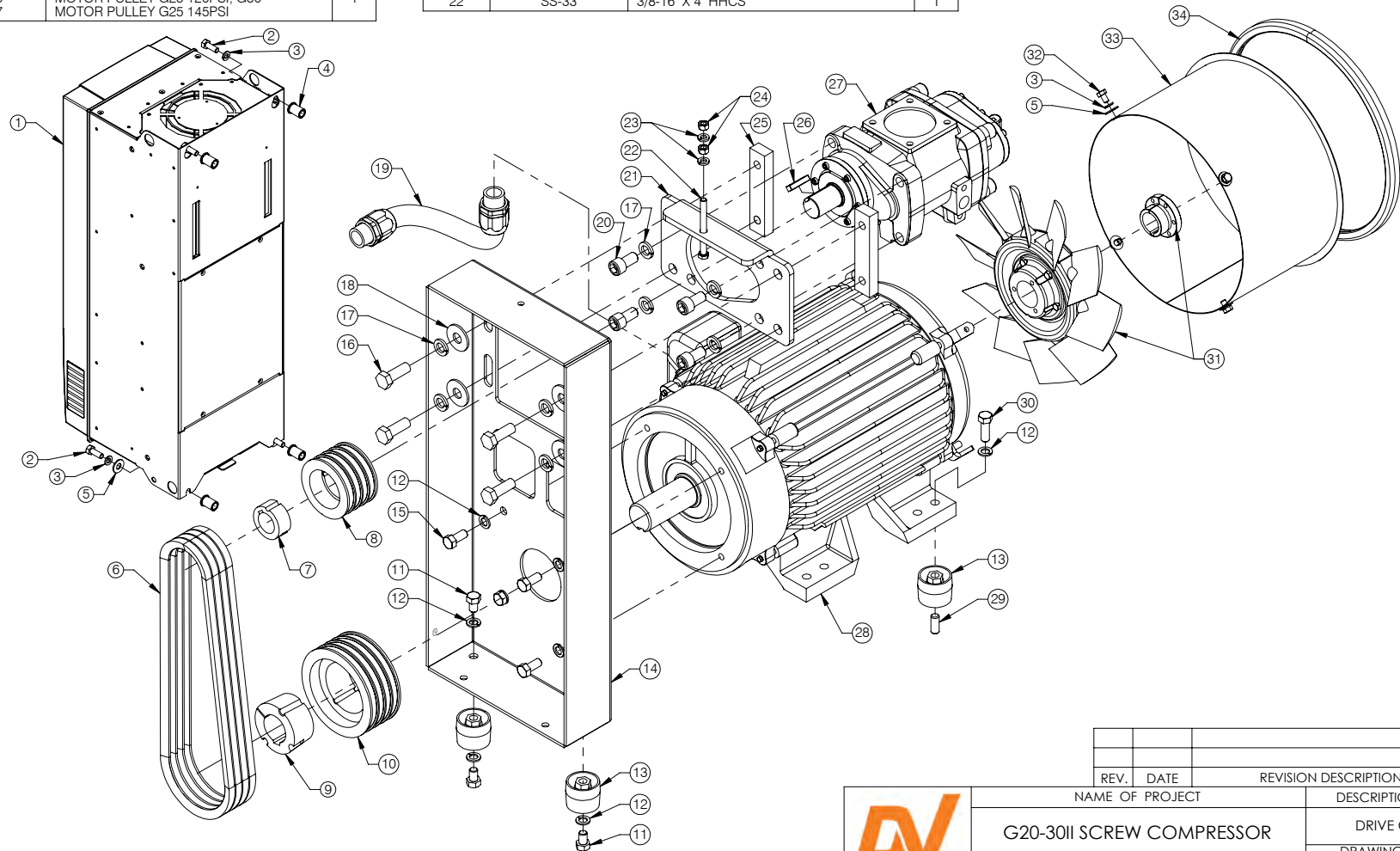

REV.	DATE	REVISION DESCRIPTION	PCN NO.



NAME OF PROJECT				DESCRIPTION OF DRAWING	
G20-30II SCREW COMPRESSOR				DRIVE COMPONENTS	
DRAWN BY	CHECKED BY	DATE	SCALE	DRAWING NO.	SHT NO/REV.
LT		2/08/17	N.T.S	G20-30II	D1

IMPORTANT NOTE: This print is the confidential property of DV SYSTEMS, INC. It is not to be used or reproduced in any manner, nor submitted to other parties for examination without the prior approval of DV SYSTEMS, INC.

ITEM NO.	PART NUMBER	DESCRIPTION	QTY.
1	DSC-001961	G-SERIES AIR FILTER	1
2	DSC-001962	G-SERIES INTAKE FILTER CLAMP	1
3	DSC-001965	G-SERIES INTAKE VALVE COLLAR	1
4	SS-10114	M10 X 30MM HHCS	4
5	SS-1525	3/8" FLAT WASHER	7
6	DSC-001960	G-SERIES INTAKE VALVE	1
7	DSC-002044	O-RING AIR END-INTAKE VALVE	1
8	DSC-001186	AIR END G-SERIES	1
9	DSC-200	BONDED WASHER 1/2" BSPP	1
10	DSC-001214	ADAPTER 1/2"BSPP - JIC 8	1
11	DSC-001907	OIL SIGHT GLASS 3/4" BSPP	1
12	DSC-002259	COPPER WASHER 3/4"BSPP WD	1
13	DSC-618	OIL FILL PLUG 3/4" BSPP	1
14	DSC-120	BONDED WASHER 3/4" BSPP	6
15	DSC-001393-2	AIR/OIL RECEIVER G-SERIES II	1
16	DSC-001146	G20-30 FLEXI HOSE GASKET	2
17	R-8504	PE TUBING 1/2" OD	1
18	DD-00091	3/8"NPT X 1/2"DIA PNEU. FITTING	1
19	DSC-002828	BALL VALVE 3/8" NPTF X 3/8" NPTF	1
20	DSC-002826	ADAPTER 3/8"NPT(M) - 3/8"NPT(M)	1
21	DSC-244	M12 HC LOCKWASHER	8
22	DSC-294	M12-1.75 X 30 SHCS	8
23	DSC-001330	VIBRATION ISOLATOR	3
24	SS-1502	3/8" LOCKWASHER	3
25	SS-657	3/8-16 HEX NUT	3
26	DSC-002880	FLEXI-HOSE G-SERIES II	1
27	DSC-002884	3/4 STEEL TUBE OIL FROM COOLER	1
28	DSC-002887	3/4 STEEL AIR OUT	1
29	DSC-124	ADAPTER 1-1/4"BSPP(M) - JIC 12	1
30	DSC-002724	O-RING C-SERIES THERMOVALVE INLET	1
31	DSC-002882	O-RING G-SERIES A/O INLET	1
32	DSC-122	BONDED WASHER 1-1/4"BSPP	1
33	DSC-121	ADAPTER R3/4" - JIC12	4
34	SS-01926	3/8-16 X 1-3/4 SHCS	4
35	DSC-624	OIL FILTER	1
36	DSC-002881	MANIFOLD ASSEMBLY G-SERIES II	1
37	DSC-628	MANIFOLD SCAVENGE LINE O-RING	1
38	DSC-288	MANIFOLD ASSEMBLY O-RING	1
39	DSC-567	ADAPTER R3/4" - JIC8	1
40	DSC-002886	1/2 STEEL TUBE OIL RETURN	1
41	DSC-001667	COPPER SEALING RING 1/8"BSPP	2
42	DSC-001235	G20-30 SEPARATOR TUBE	1
43	DSC-001148	AIR/OIL SEPARATOR FILTER	1
44	DSC-002883	3/4 STEEL TUBE OIL TO COOLER	1
45	DSC-001150	HEAT EXCHANGER	1
46	SS-725	5/16" HEX NUT	6
47	SS-1503	5/16" LOCKWASHER	6
48	SS-1524	5/16" FLAT WASHER	12
49	SS-159	5/16-18 X 3.75" HHCS	6
50	DSC-002151	ADAPTER 1"NPT(M) - JIC 12	2
51	DSC-002888	3/4 STEEL TUBE DRYER INLET	1
52	DSC-237	ADPTR 3/4"NPT(M)-JIC12(M) (FLR-MTD ONLY)	1

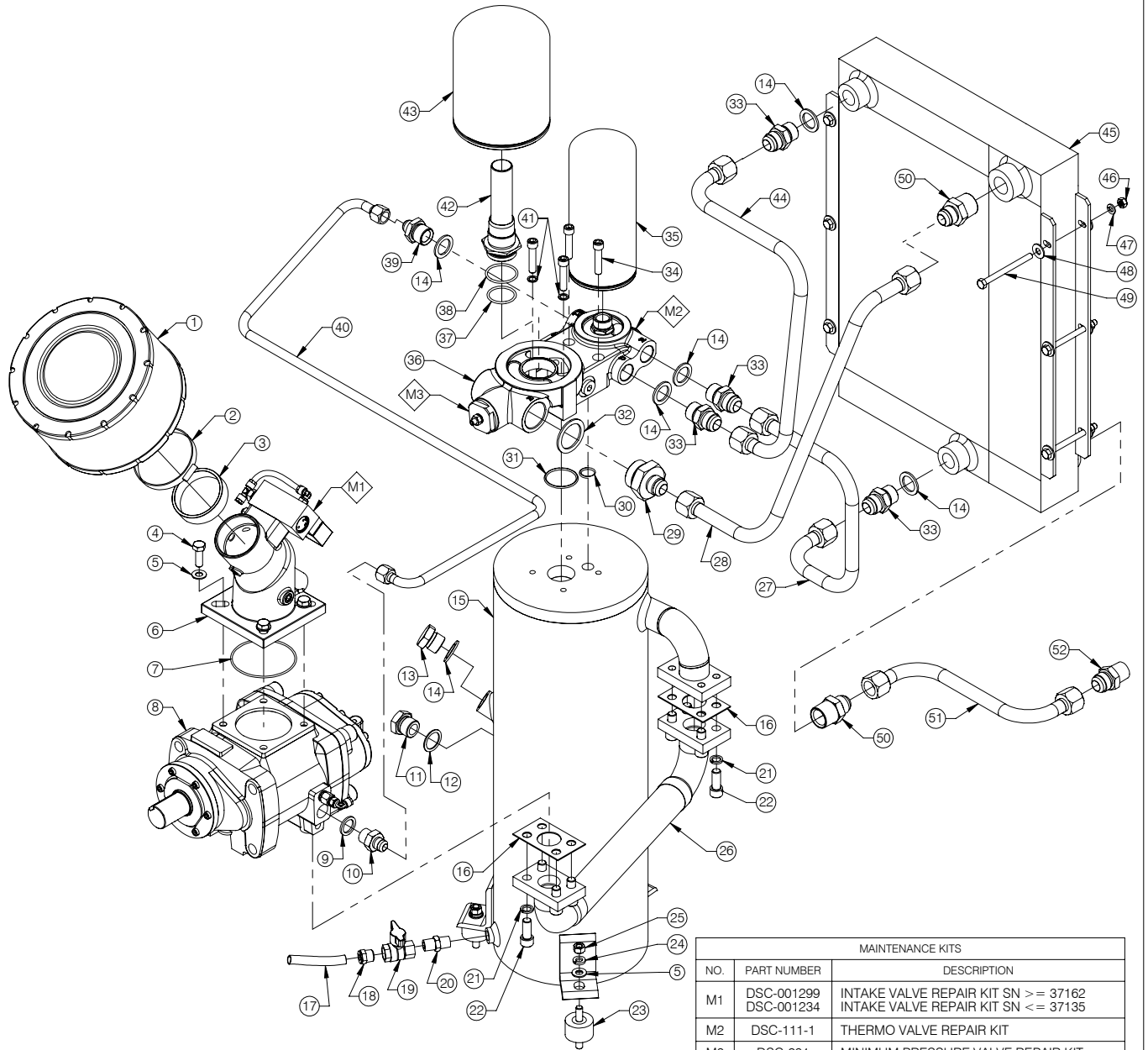

MAINTENANCE KITS		
NO.	PART NUMBER	DESCRIPTION
M1	DSC-001299 DSC-001234	INTAKE VALVE REPAIR KIT SN >= 37162 INTAKE VALVE REPAIR KIT SN <= 37135
M2	DSC-111-1	THERMO VALVE REPAIR KIT
M3	DSC-231	MINIMUM PRESSURE VALVE REPAIR KIT
---	MK-G20-30-1 MK-G20-30	4000 HOUR MAINTENANCE KIT SN >= 37162 4000 HOUR MAINTENANCE KIT SN <= 37135

IMPORTANT NOTE: This print is the confidential property of DV SYSTEMS, INC. It is not to be used or reproduced in any manner, nor submitted to other parties for examination without the prior approval of DV SYSTEMS, INC.

REV.	DATE	REVISION DESCRIPTION	PCN NO.



NAME OF PROJECT				DESCRIPTION OF DRAWING	
G20-30II SCREW COMPRESSOR				SYSTEM COMPONENTS	
DRAWN BY	CHECKED BY	DATE	SCALE	DRAWING NO.	SHT NO/REV.
LT		2/17/17	N.T.S	G20-30II	D2

ITEM NO.	PART NUMBER	DESCRIPTION	QTY.
1	DSC-001186	AIR END G-SERIES	1
2	DSC-001960	G-SERIES INTAKE VALVE	1
3	DSC-381	PNEUMATIC TUBE BLACK 8MM OD	2
4	DSC-002209	INTAKE VALVE CONTROL BLOCK	1
5	DSC-376	PNEUMATIC ELBOW 1/8"BSPP X 8MM	1
6	DSC-002052	SOLENOID G-SERIES N.C.	1
7	DSC-002872	SOLENOID CABLE G-SERIES	1
8	DSC-263	1/8" BONDED WASHER	1
9	DSC-677	ORIFICE 1MM	1
10	DSC-185	PNEUMATIC ELBOW 1/8"BSPP X 6MM	1
11	DSC-001217	BONDED WASHER 1/4" BSPP	2
12	DSC-001238	TEMPERATURE SENSOR CSC200300	1

ITEM NO.	PART NUMBER	DESCRIPTION	QTY.
13	DSC-110	PNEUMATIC TEE 1/4"BSPP X 8MM	1
14	DSC-712	THERMO VALVE CAP	1
15	DSC-711	THERMO VALVE CAP O-RING	1
16	DSC-120	BONDED WASHER 3/4" BSPP	3
17	DSC-567	ADAPTER R3/4" - JIC8	1
18	DSC-001564	ADAPTER 1/4"BSPPM - 1/4"NPTF	1
19	TIA-5165	SAFETY VALVE 1/4" 165 PSI	1
20	DSC-158	PNEUMATIC ELBOW 1/4"BSPP X 6MM	1
21	DSC-427	BONDED WASHER 3/8"	2
22	DSC-278	ADAPTER 3/8"BSPP X 1/4"BSPP	2
23	DSC-377	PNEUMATIC ELBOW 1/4"BSPP X 8MM	1
24	DSC-382	PNEUMATIC TUBE NATURAL 6MM OD	2

ITEM NO.	PART NUMBER	DESCRIPTION	QTY.
25	DSC-002872	SOLENOID CABLE ASSEMBLY G	1
26	DSC-001237	PRESSURE TRANSDUCER CSC200300	1
27	DSC-175	PNEUMATIC STRAIGHT 1/8" X 6MM	2
28	DSC-001358	CHECK VALVE 1/8"NPT(F)	1
29	DSC-612	INLINE FILTER	1
30	DSC-002881	MANIFOLD ASSEMBLY G-SERIES II	1
31	DSC-002717	PLUG 3/8" BSPP	1

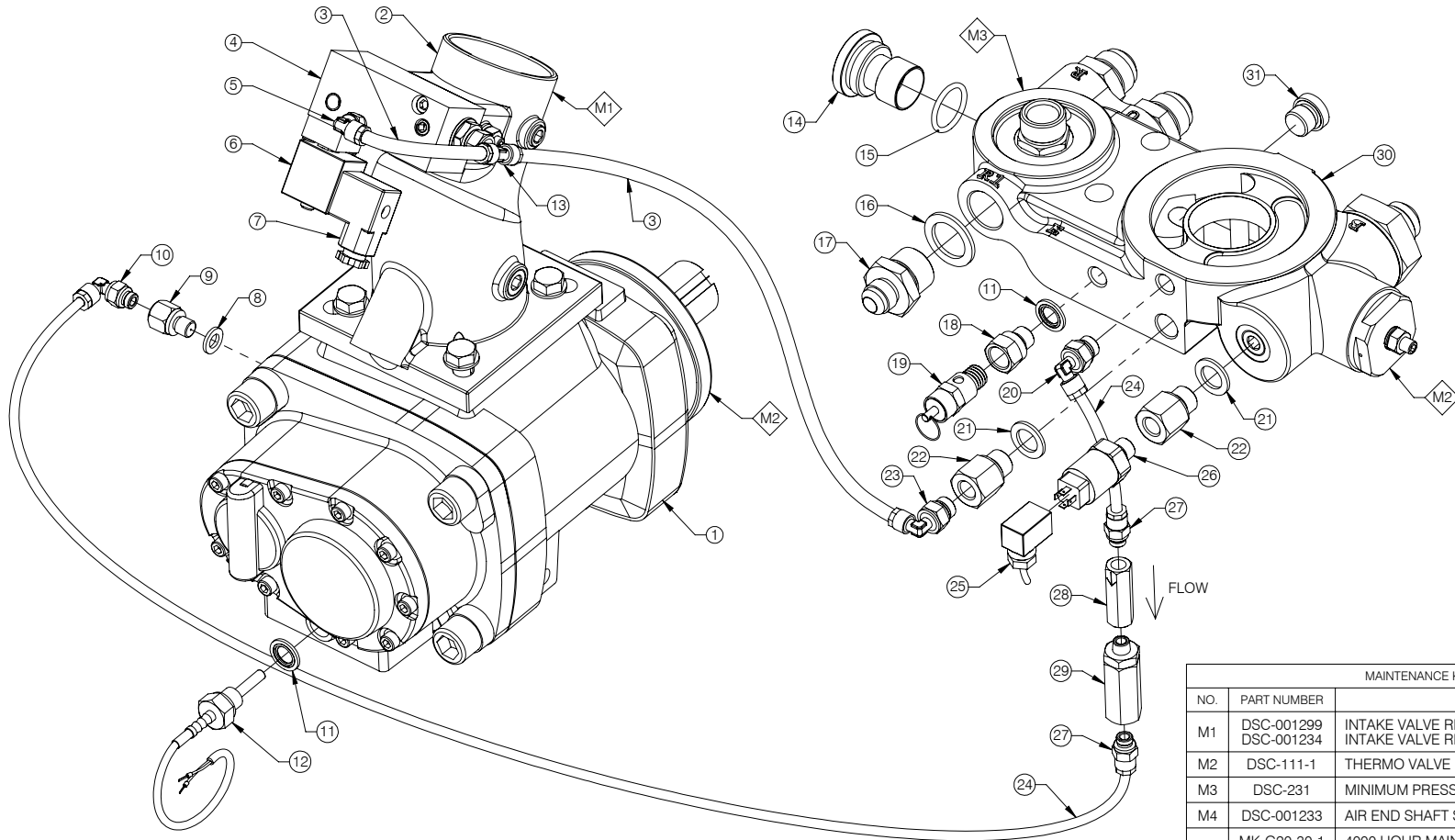

MAINTENANCE KITS		
NO.	PART NUMBER	DESCRIPTION
M1	DSC-001299	INTAKE VALVE REPAIR KIT SN >= 37162
	DSC-001234	INTAKE VALVE REPAIR KIT SN <= 37135
M2	DSC-111-1	THERMO VALVE REPAIR KIT
M3	DSC-231	MINIMUM PRESSURE VALVE REPAIR KIT
M4	DSC-001233	AIR END SHAFT SEAL KIT
---	MK-G20-30-1	4000 HOUR MAINTENANCE KIT SN >= 37162
	MK-G20-30	4000 HOUR MAINTENANCE KIT SN <= 37135

IMPORTANT NOTE: This print is the confidential property of DV SYSTEMS, INC. It is not to be used or reproduced in any manner, nor submitted to other parties for examination without the prior approval of DV SYSTEMS, INC.

REV.	DATE	REVISION DESCRIPTION	PCN NO.



NAME OF PROJECT				DESCRIPTION OF DRAWING	
G20-30II SCREW COMPRESSOR				PNEUMATIC COMPONENTS	
DRAWN BY	CHECKED BY	DATE	SCALE	DRAWING NO.	SHT NO/REV.
LT		2/10/17	N.T.S	G20-30II	D3

POWER CIRCUIT SCHEMATIC

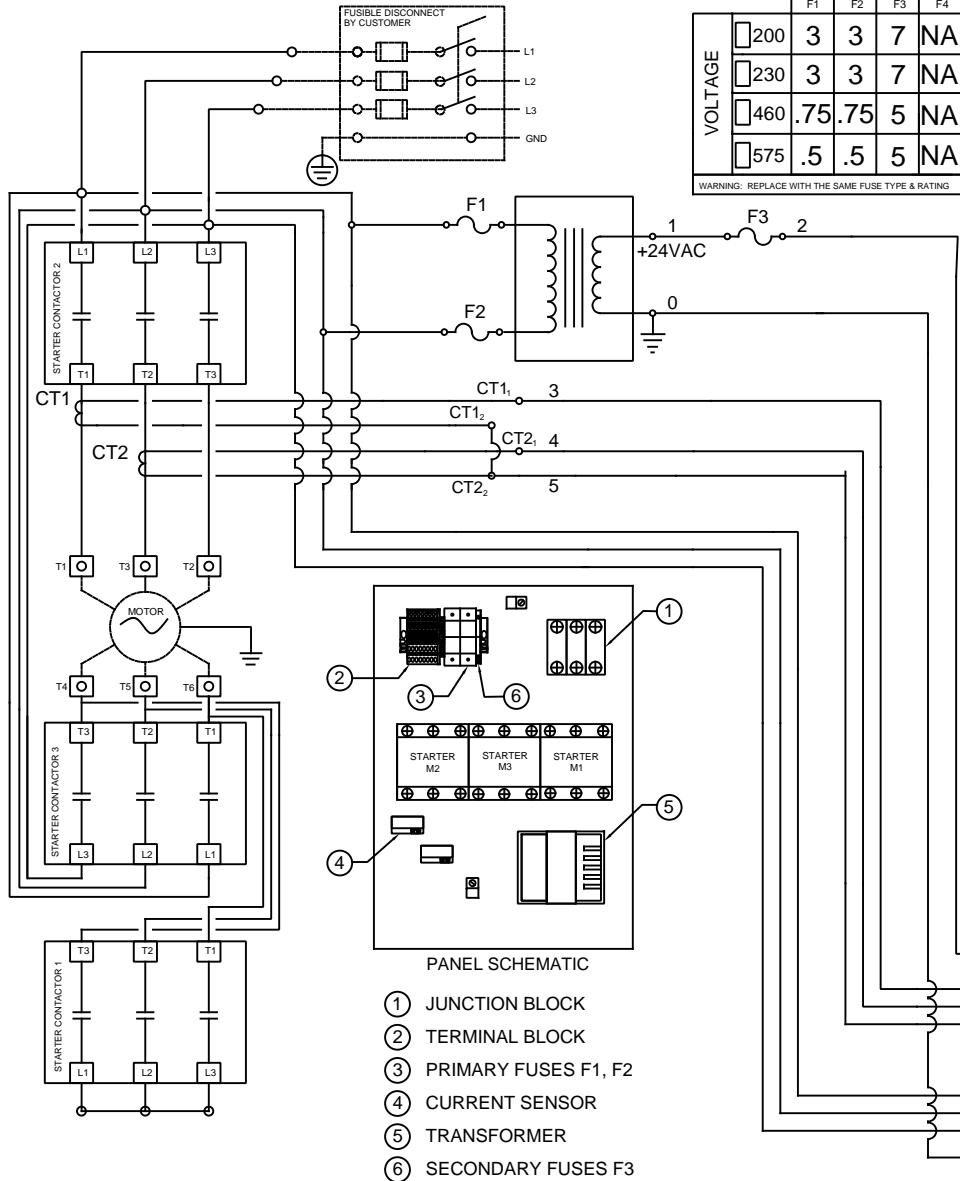

- PANEL SCHEMATIC
- ① JUNCTION BLOCK
 - ② TERMINAL BLOCK
 - ③ PRIMARY FUSES F1, F2
 - ④ CURRENT SENSOR
 - ⑤ TRANSFORMER
 - ⑥ SECONDARY FUSES F3

FUSE TABLE					
		ATOR, CC		5MM	
		F1	F2	F3	F4
VOLTAGE	200	3	3	7	NA
	230	3	3	7	NA
	460	.75	.75	5	NA
	575	.5	.5	5	NA

WARNING: REPLACE WITH THE SAME FUSE TYPE & RATING

REV.	DATE	REVISION DESCRIPTION	PCN NO.
C	01/29/16	G-SERIES 575V SEC. FUSE RATING CORRECTED	---
D	02/15/17	DISCONNECT NOTES REMOVED	---

- E - EMERGENCY STOP
 - CT1 - CURRENT TRANSFORMER #1
 - CT2 - CURRENT TRANSFORMER #2
 - M1 - STARTER COIL 1
 - M2 - STARTER COIL 2
 - M3 - STARTER COIL 3
 - P - PRESSURE TRANSDUCER
 - S - SOLENOID N.O.
 - T - TEMPERATURE SENSOR
 - RSS - REMOTE START/STOP, N/O
- (FIELD OPTION:
INSTALL RSS TO #17 AND #12
TERMINAL BLOCK. INSTALL WIRE
FROM #17 TO DI5. ON P18 CHANGE
P18.08 FROM 'OFF' TO 'DI REMOTE START'.
ON P10 CHANGE P10.12 FROM 'KEYPAD'
TO 'EQUIPMENT DI'.)
X07 - R7 AND R8 FOR PROGRAMMABLE RELAY
OUTPUT FUNCTION

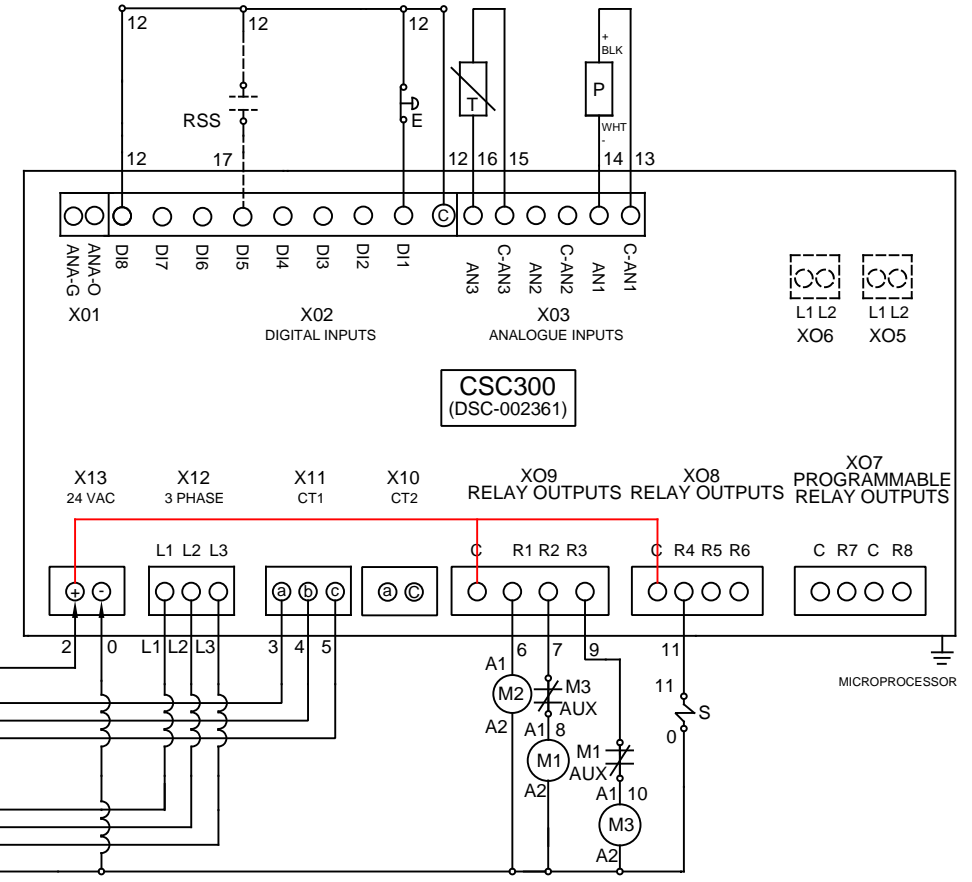

IMPORTANT NOTE: This print is the confidential property of DV SYSTEMS, INC. It is not to be used or reproduced in any manner, nor submitted to other parties for examination without the prior approval of DV SYSTEMS, INC. DV SYSTEMS, INC. is continuously trying to improve its products, specifications subject to change without notice.

FRACTIONAL DIMENSIONS: ±1/32
DECIMAL DIMENSION: ±.005
ANGLES: ±1°
*UNLESS OTHERWISE SPECIFIED



NAME OF PROJECT				DESCRIPTION OF DRAWING			
G-SERIES FIXED SPEED COMPRESSOR CSC300 CONTROLLER				ELECTRICAL SCHEMATICS WITH MICROPROCESSOR			
DRAWN BY		CHECKED BY		DATE		SCALE	
EH				01/29/16		N.T.S.	
				DRAWING NO.		SHT NO/REV	
				CSC300G		D	

REV.	DATE	REVISION DESCRIPTION	PCN NO.
	01/27/17	NEW PRODUCT	15-24

- E - EMERGENCY STOP
- P - PRESSURE TRANSDUCER
- S - SOLONOID N.C.
- T - TEMPERATURE SENSOR
- RSS - REMOTE START/STOP

(FIELD OPTION:
 INSTALL RSS TO #16 AND #10 TERMINAL BLOCK.
 INSTALL WIRE FROM #16 TO DI5. ON P18 CHANGE P18.08 FROM 'OFF' TO 'DI REMOTE START'.
 ON P10 CHANGE P10.12 FROM 'KEYPAD' TO 'EQUIPMENT DI')
 X07 - R7 AND R8 FOR PROGRAMMABLE RELAY OUTPUT FUNCTION

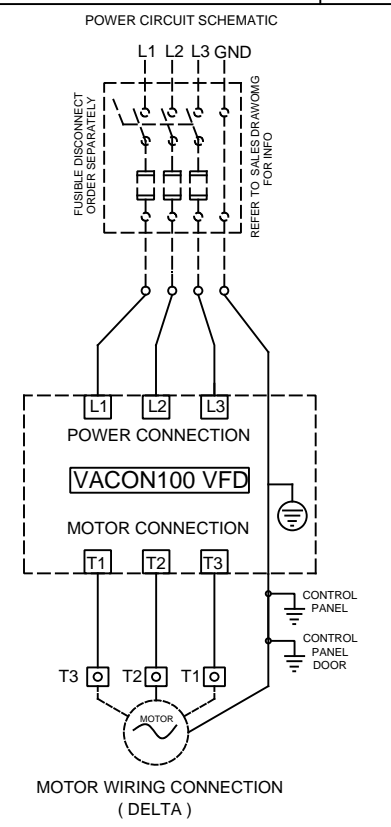
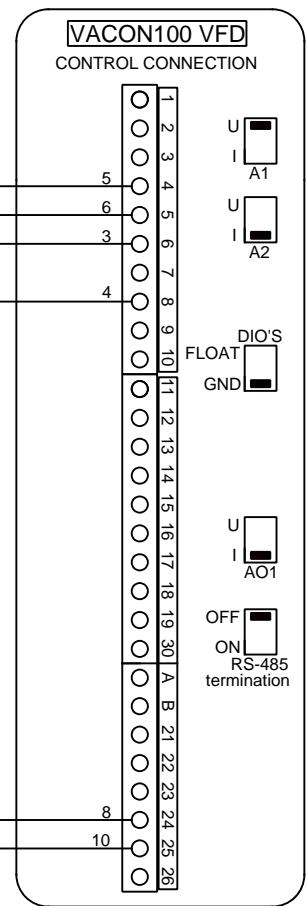
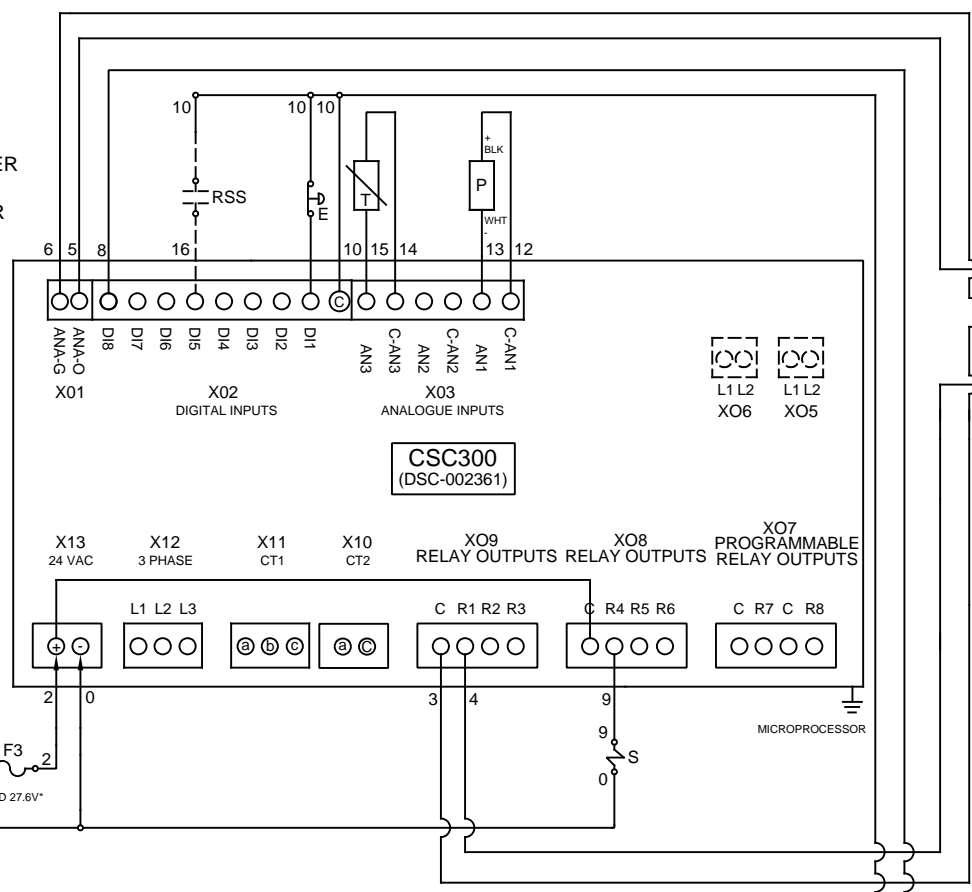

VOLTAGE	FUSE TABLE			
	ATOR F1	CC F2	3MM F3	5MM F4
200	1.5	1.5	5	NA
230	1.5	1.5	5	NA

WARNING: USE THE SAME FUSE TYPE & RATING

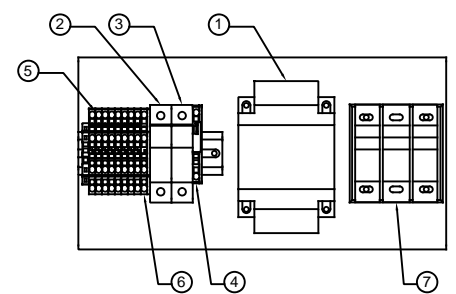

- PANEL SCHEMATIC
- ① TRANSFORMER
 - ② PRIMARY FUSE F1
 - ③ PRIMARY FUSE F2
 - ④ SECONDARY FUSE F3
 - ⑤ TERMINAL BLOCK
 - ⑥ GROUND TERMINAL
 - ⑦ POWER BLOCK

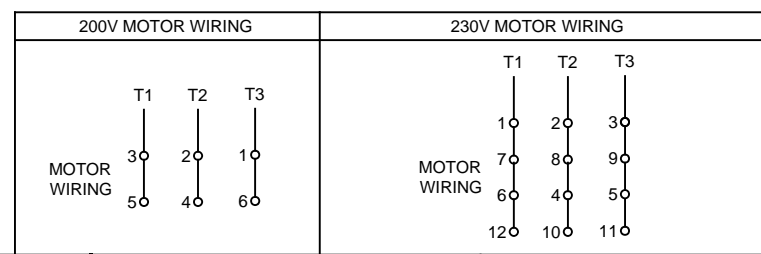

IMPORTANT NOTE: This print is the confidential property of DV SYSTEMS, INC. It is not to be used or reproduced in any manner, nor submitted to other parties for examination without the prior approval of DV SYSTEMS, INC. DV SYSTEMS, INC. is continuously trying to improve its products, specifications subject to change without notice.

FRACTIONAL DIMENSIONS: $\pm 1/32$
 DECIMAL DIMENSION: $\pm .005$
 ANGLES: $\pm 1^\circ$
 *UNLESS OTHERWISE SPECIFIED



NAME OF PROJECT				DESCRIPTION OF DRAWING		
SCREW COMPRESSOR VARIABLE SPEED CONTROLS G25-30 II, 200/230V				ELECTRICAL SCHEMATICS CSC300 & VACON 100 VFD		
DRAWN BY CHECKED BY DATE SCALE				DRAWING NO. SHT NO REV		
E.H.				GII-VSD-CSC300-200230		

REV.	DATE	REVISION DESCRIPTION	PCN NO.
	01/27/17	NEW PRODUCT	15-24

E - EMERGENCY STOP
 P - PRESSURE TRANSDUCER
 S - SOLENOID N.C.
 T - TEMPERATURE SENSOR
 RSS - REMOTE START/STOP
 (FIELD OPTION:
 INSTALL RSS TO #16 AND
 #10 TERMINAL BLOCK.
 INSTALL WIRE FROM #16
 TO DI5. ON P18 CHANGE
 P18.08 FROM 'OFF' TO
 'DI REMOTE START'.
 ON P10 CHANGE P10.12
 FROM 'KEYPAD' TO
 'EQUIPMENT DI')
 X07 - R7 AND R8 FOR
 PROGRAMMABLE RELAY
 OUTPUT FUNCTION

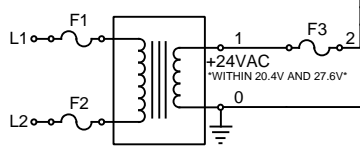
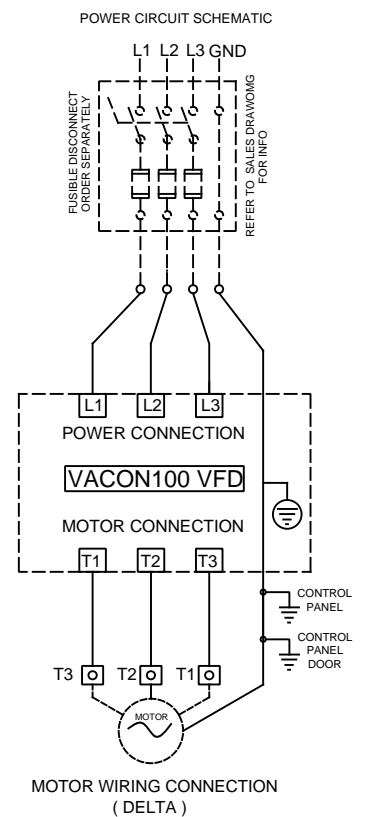
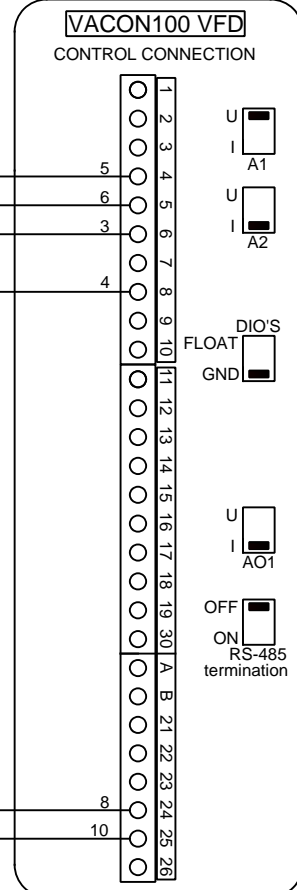
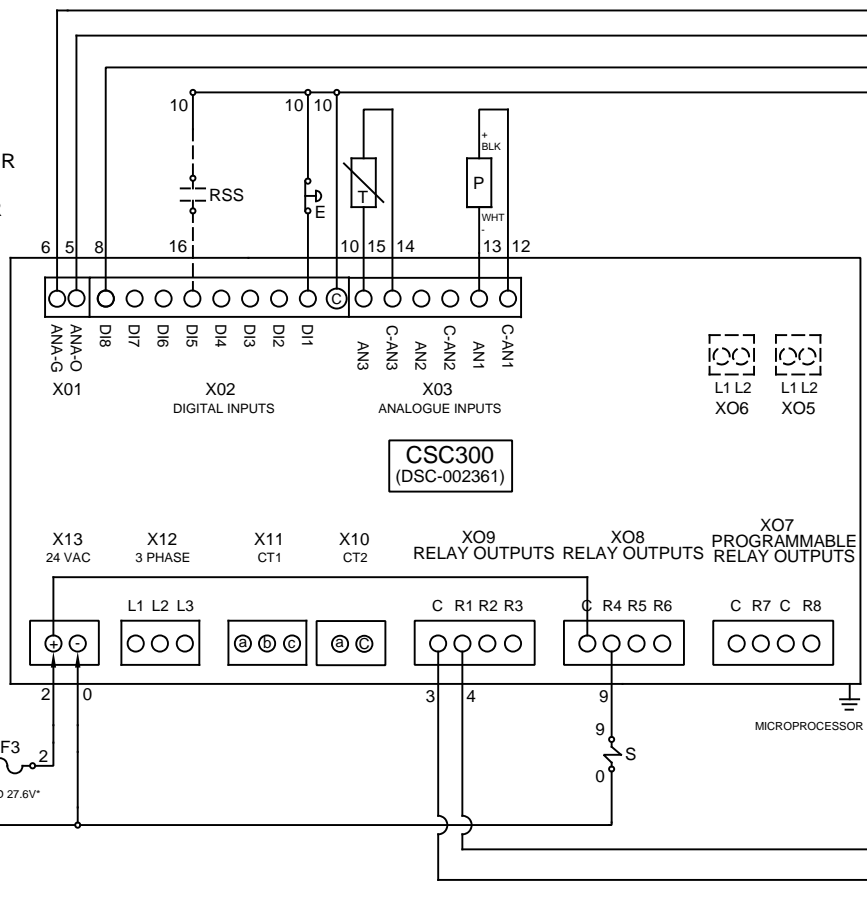

VOLTAGE	FUSE TABLE			
	ATOR F1	CC F2	3MM F3	5MM F4
460	.75	.75	5	NA
575	.5	.5	5	NA

WARNING: USE THE SAME FUSE TYPE & RATING

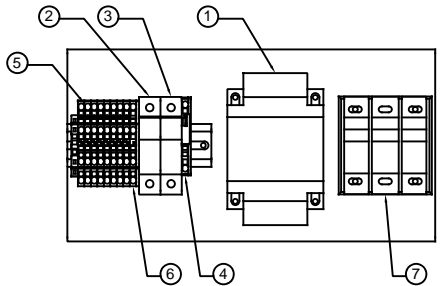

- PANEL SCHEMATIC
- ① TRANSFORMER
 - ② PRIMARY FUSE F1
 - ③ PRIMARY FUSE F2
 - ④ SECONDARY FUSE F3
 - ⑤ TERMINAL BLOCK
 - ⑥ GROUND TERMINAL
 - ⑦ POWER BLOCK

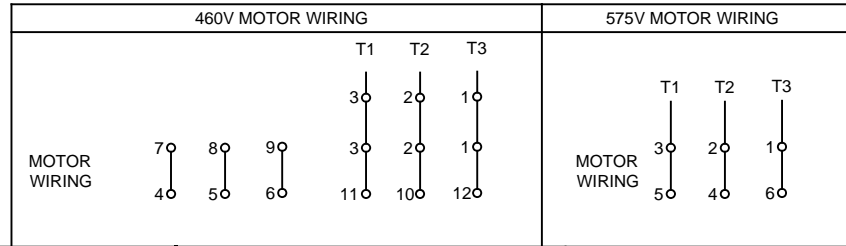

IMPORTANT NOTE: This print is the confidential property of DV SYSTEMS, INC. It is not to be used or reproduced in any manner, nor submitted to other parties for examination without the prior approval of DV SYSTEMS, INC. DV SYSTEMS, INC. is continuously trying to improve its products, specifications subject to change without notice.

FRACTIONAL DIMENSIONS: $\pm 1/32$
 DECIMAL DIMENSION: $\pm .005$
 ANGLES: $\pm 1^\circ$
 *UNLESS OTHERWISE SPECIFIED



NAME OF PROJECT				DESCRIPTION OF DRAWING		
SCREW COMPRESSOR VARIABLE SPEED CONTROLS G25-30 II 460/575V				ELECTRICAL SCHEMATICS CSC300 & VACON100 VFD		
DRAWN BY		CHECKED BY	DATE	SCALE	DRAWING NO.	SHT NO/REV
E.H.			01/24/17	N.T.S.	GII-VSD-CSC300-460575	