

Data sheet

Electric regulating valves

Type CCMT 2 - CCMT 8 / CCMT 16 - CCMT 42



The CCMT is an electrically operated valve designed specifically for operation in CO₂ systems.

The CCMT valve concept is designed to fulfil global refrigeration requirements.

The valve is capable of functioning either as an expansion valve, as a pressure regulator for the gascooler or as a gas bypass valve with back-pressure regulation in transcritical or subcritical applications.

Features

- Designed for CO₂ systems with maximum working pressure of 140 bar / 2030 psig.
- Applicable to R744 (CO₂) and other common refrigerants. The CCMT is compatible with the oil types PAG, POE and PVE.
- Regulating cone ensures optimum regulating accuracy, particularly at part load.
- Patented cone and balance design.
- The PEEK seat provides excellent valve tightness and robustness.
- Combined butt weld and solder connections.
- Top part with built-in strainer / filter.
- MOPD up to 90 bar / 1305 psi
- CCMT 16 – CCMT 42 is designed with integrated pressure transmitter.
- Standard M12 connector for simple and flexible connection to the motor driver.
- Low weight and compact design.
- Easy to service. Insert easily taken out by removing top part.
- For manual operation and service of the CCMT an AST-g service driver is available.



For more information on the product, please scan the QR code.

Technical data

Parameter	CCMT 2 – CCMT 8	CCMT 16 - CCMT 42
Compatibility refrigerants	R744 and other refrigerants. Not applicable for flammable refrigerants and Ammonia.	R744 and other refrigerants. Not applicable for flammable refrigerants and Ammonia.
Refrigerant oils	PAG, POE and PVE	PAG, POE and PVE
MOPD	90 bar / 1305 psi	90 bar / 1305 psi
Max. working pressure (PS/MWP)	140 bar / 2030 psig	140 bar / 2030 psig
Refrigerant temperature range*	-40 – 60 °C / -40 – 140 °F	-40 – 60 °C / -40 – 140 °F
Ambient temperature	-40 – 60 °C / -40 – 140 °F	-40 – 60 °C / -40 – 140 °F

* Measured at inlet of the valve

Material specification	Stainless steel	Stainless steel
Expected lifetime	Min. 15 years	Min. 10 years
Build in strainer / filter	Yes, 6 slots, 1.1 mm height x 10 mm wide	Yes, 250 micron
Comply with P.E.D.	Fluid group I / Article 3, paragraph 3	Fluid group I / Article 3, paragraph 3
Approval	CE and UL approved	CE, UL, EAC, cUL, CRN

Electrical data

Parameter	CCMT 2 – CCMT 8	CCMT 16 - CCMT 42
Stepper motor type	Bi-polar - permanent magnet	Bi-polar - permanent magnet
Motor enclosure	IP 67	IP 67
Step mode	2 phase full step, microstepping (recommended)	2 phase full step, microstepping (recommended)
Phase resistance	52 Ω ±10%	29 Ω ±10%
Phase inductance	85 mH	36.7 mH
Phase current	Using chopper drive: 100 mA RMS -4 % +15 %	Using chopper drive: 300 mA RMS -4 % +15 %
Holding current	Voltage driver: Depends on application. Current controller: Full current allowed	Not needed.
Duty cycle	100% duty cycle is allowed / 20% recommended	100% duty cycle is allowed / 20% recommended
Max. total power	Voltage drive: 5.5 W Current drive: 1.3 W (UL: NEC class 2)	Voltage drive: 10W Current drive: 2.8 W
Step rate	Chopper current drive: Max. 300 steps/sec. (Recommended step rate: 200 steps/sec.) Constant voltage drive: Max. 150 steps/sec.	Chopper current drive: Max. 300 steps/sec. (Recommended step rate: 200 steps/sec.) Constant voltage drive: Max. 150 steps/sec.
Total full steps	CCMT 2, 4 and 8: 1100 steps	CCMT 16 : 800, CCMT 24 : 1400, CCMT 30 : 2300 and CCMT 42 : 2200
Full travel time	CCMT 2, 4 and 8: 5 sec. (at 220 steps/sec.)	CCMT 16 : 4 sec., CCMT 24 : 7 sec. CCMT 30 : 11.5 sec. and CCMT 42 : 11 sec. (at 200 steps/sec.)
Reference position	Overdriving against full close position	Overdriving against full close position
Overdrive in close position	Max. 10% of total full steps	Max. 10% of total full steps and maximum one overdrive performed per hour.
Overdrive in open position	Not Allowed	Not Allowed
Electrical connection	M12 male connector with 0.3 m / 1 ft long cable (4 wire: 0.5 mm ² / 20 AWG)	Integrated M12 male connector

Compatible controllers	EKD 316 / EKD 316C, EKC 316A, EKC 313, EKC 326A, AK-XM 208C	EKD 316 / EKD 316C, AK-XM 208C
------------------------	--	--------------------------------

Pressure transmitter MBS 8250 (CCMT 16 - CCMT 42)

Pressure range	- 1 to 159 bar / 14.5 – 2306 psi sealed gauge
Electrical connection	Round Packard Metripack
Output signal	10 - 90 % of V supply
Supply voltage	5V DC ± 0.5V
Process connection	7/16-20 UNF-2A ISO 11926-2; Viton o-ring

Ordering
Valve including actuator

Type	Connections		Flow rate		Single pack	Code no.
	Weld ¹⁾ [in]	Solder ODF x ODF [in]	k _v [m ³ /h]	C _v [gpm]		
CCMT 4	1/2 × 1/2	5/8 × 5/8	0.45	0.52	1	027H7201
CCMT 8	1/2 × 1/2	5/8 × 5/8	0.8	0.92	1	027H7202
CCMT 16	1 × 1	1 1/8 × 1 1/8	1.6	1.85	1	027H7231
CCMT 24	1 × 1	1 1/8 × 1 1/8	2.4	2.77	1	027H7232
CCMT 30	1 × 1	1 1/8 × 1 1/8	3.0	3.47	1	027H7233
CCMT 42	1 × 1	1 1/8 × 1 1/8	4.2	4.86	1	027H7234

¹⁾OD according to EN 10220

M12 cable

Cable	Temperature range		Cable length		Connection	Single pack	Code no.
	[°C]	[°F]	[m]	[ft]			
PVC black	-50 – 80	-58 – 176	2	6.6	4 wires 0.33 mm ² / 22 AWG	1	034G2201
	-50 – 80	-58 – 176	8	26.2		1	034G2200
CPE grey	-40 – 80	-40 – 176	2	6.6	4 wires 0.5 mm ² / 20 AWG	1	034G2202
	-40 – 80	-40 – 176	3	9.8		1	034G2203
	-40 – 80	-40 – 176	5	16.4		1	034G2205

Cable	Temperature range		Cable length		Connection [4 wires]	Industrial pack	Code no.
	[°C]	[°F]	[m]	[ft]			
PVC black	-50 – 80	-58 – 176	2	6.6	0.33 mm ² / 22 AWG	20	034G2330
	-50 – 80	-58 – 176	8	26.2		20	034G2323
CPE grey	-40 – 80	-40 – 176	2	6.6	0.5 mm ² / 20 AWG	20	034G2331

Packard cable for MBS 8250

Type	Description	Industrial pack	Code no.
Packard cable	10 m / 32.8 ft cable for MBS 8250 pressure transmitter	14	064G0910

Related products

Type	Description	Single pack	Code no.
AK-XM 208C	Stepper output module	1	080Z0023
EKD 316	Superheat controller / driver	1	084B8040
EKD 316C	Superheat controller / driver	1	084B8045
EKA 164A	Optional display for EKD 316	1	084B8563
AKA 211	Cable filter	1	084B2238
AST-G	Manual service driver	1	034G0013

Spareparts

Type	Description	Single pack	Code no.
Gasket	O-ring spare part kit for CCM / CCMT 2 - CCMT 42	1	027H7230

Related products

Superheat controller / driver, type EKD 316 / EKD 316C



Electronic controller type EKC 326 and EKC 313



Electronic driver type AK-XM 208C



Temperature sensors type AKS and pressure transmitters type MBS

Design

- 1a. Cable with M12 male connector
- 1b. M12 connector
- 2. Actuator housing
- 3. Stepper motor
- 4. Ball bearing
- 5. Spindle
- 6. Valve housing
- 7. Balance piston
- 8a. Strainer
- 8b. Filter
- 9. Valve cone
- 10. Nozzle
- 11. Pressure transmitter

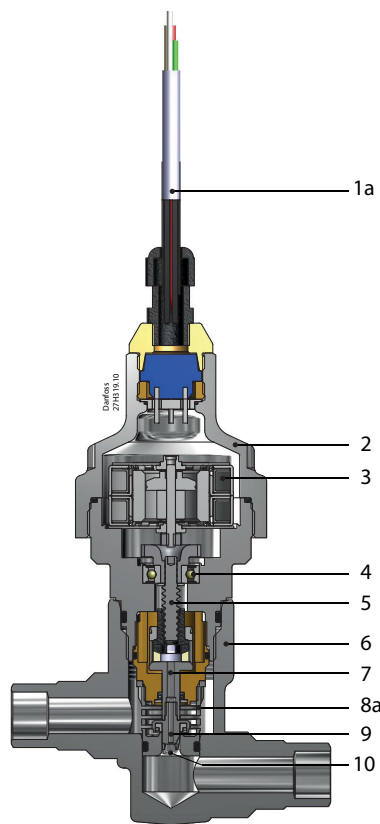

CCMT 2 - CCMT 8

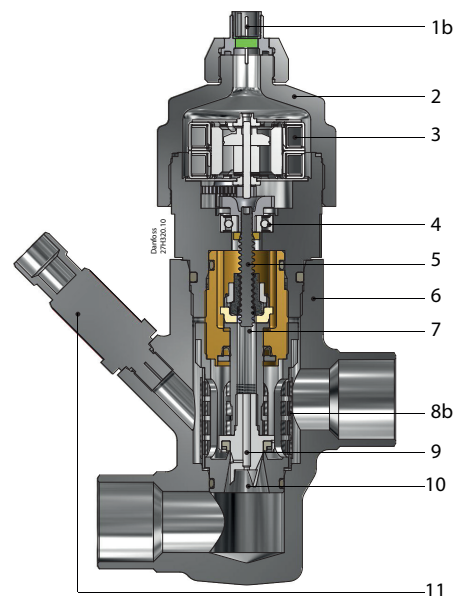

CCMT 16 - CCMT 42

Stepper motor switch sequence

		Coil I (B)				Coil II (A)			
		Red	Green	White	Black	Red	Green	White	Black
CLOSING ↑	STEP 1	+	-	+	-				
	STEP 2	+	-	-	+				
	STEP 3	-	+	-	+				
	STEP 4	-	+	+	-				
	STEP 1	+	-	+	-				
									↓ OPENING

Danfoss cable connections

Pin	Wire color
A1	White
A2	Black
B1	Red
B2	Green

CCMT valve

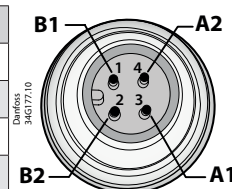

If the controller driving the CCMT valve is from another manufacturer than Danfoss or a custom design, the following points must be considered in order to overcome potential step loss.

To ensure total closing of the valve, and to compensate the lost steps after a defined number of changes in opening degree, the controller should have a function to overdrive the valve in the closing direction. It is recommended to overdrive ten percent of the full steps range at appropriate intervals.

Warning:

At power failure the CCMT valve will remain in the actual opening position it has at the moment of power failure, unless a safety device in the form of a battery backup is installed.

Application

The CCMT valve is developed for transcritical CO₂ applications. The CCMT valve can be used in systems with flash gas bypass, parallel compression as well as in stand-alone applications.

The CCMT valve can be used in transcritical and subcritical conditions.

CCMT valves are typically used as flash gas bypass and high pressure regulation.

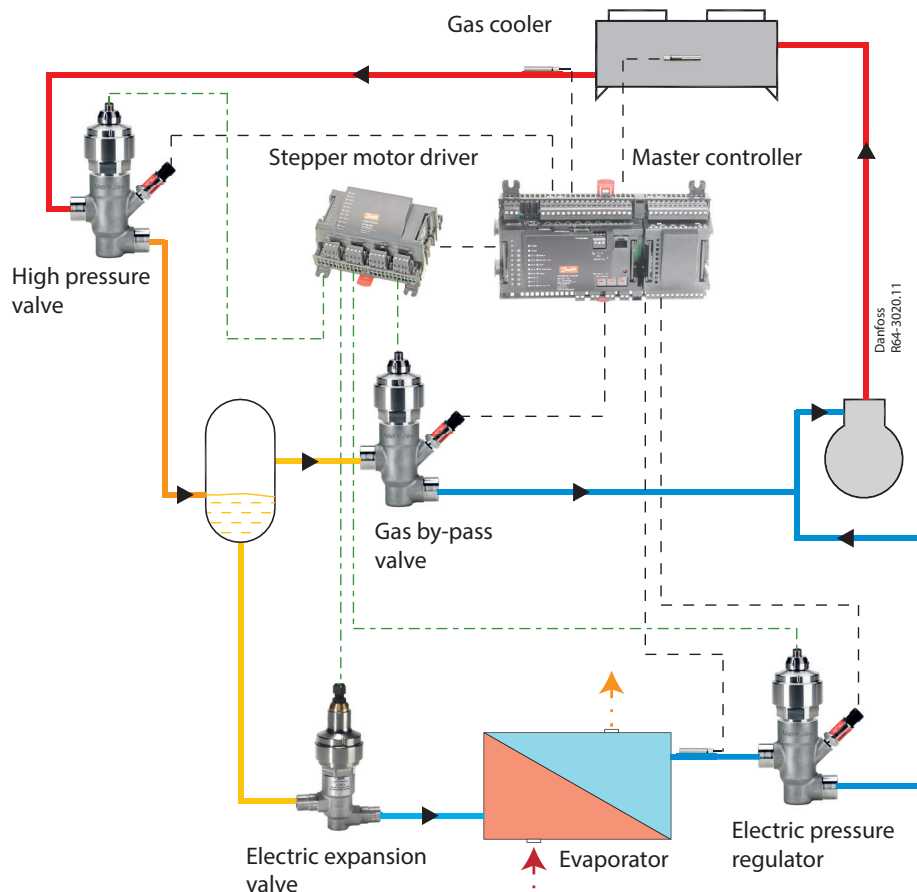

Application 1 - High Pressure Valve

The function of the high pressure valve is to control the high pressure in the system according to the reference from the controller. The reference can be set to obtain the optimum COP, optimum capacity or any other factors. Pressure optimization is performed by the CCMT valve, which is installed at the outlet of the gas cooler (see the figure above) and a matching Danfoss controller. This design provides the possibility to optimize gas cooler pressure in all situations and intermediate receiver pressure independently. Please refer to the [www.danfoss.com/CO₂](http://www.danfoss.com/CO2) for more information on CO₂ systems.

transcritical expansion, the pressure can be kept at a safe level for all components situated in the liquid lines of a transcritical CO₂ system. The two phase mixture from the CCMT valve has to be separated before gas enters the gas bypass. For use in the gas bypass application the EKC 326A controller is recommended for CCMT 2 to CCMT 8.

Application 2 - Gas bypass Valve

A gas bypass valve is typically used to regulate the intermediate pressure in a transcritical CO₂ refrigeration system, in order to keep the intermediate pressure low. By venting flash gas generated through a gas bypass valve to the suction side of the compressor after the

Application 3- Expansion Valve

A liquid expansion valve is typically used for injection in plate heat exchangers of CO₂/CO₂ cascades, or as an expansion valve for CO₂ evaporators. For the liquid injection applications CCMT 2 to CCMT 8 is used with EKC 313 controller.

Application 4 - Electric pressure regulator

With CCMT valves, it is possible to obtain an accurate temperature or pressure control by modulating the pressure in the evaporator.



Coolselector®2

is a Danfoss calculation and selection software, designed to make selection processes for all refrigeration projects easier and less time consuming. It is strongly recommended to use Coolselector®2 to find the correct valve for the application.

For fast and precise selection of valve, use Danfoss' CoolSelector2® software. You can download it from <http://coolselector.danfoss.com>

Flow characteristics

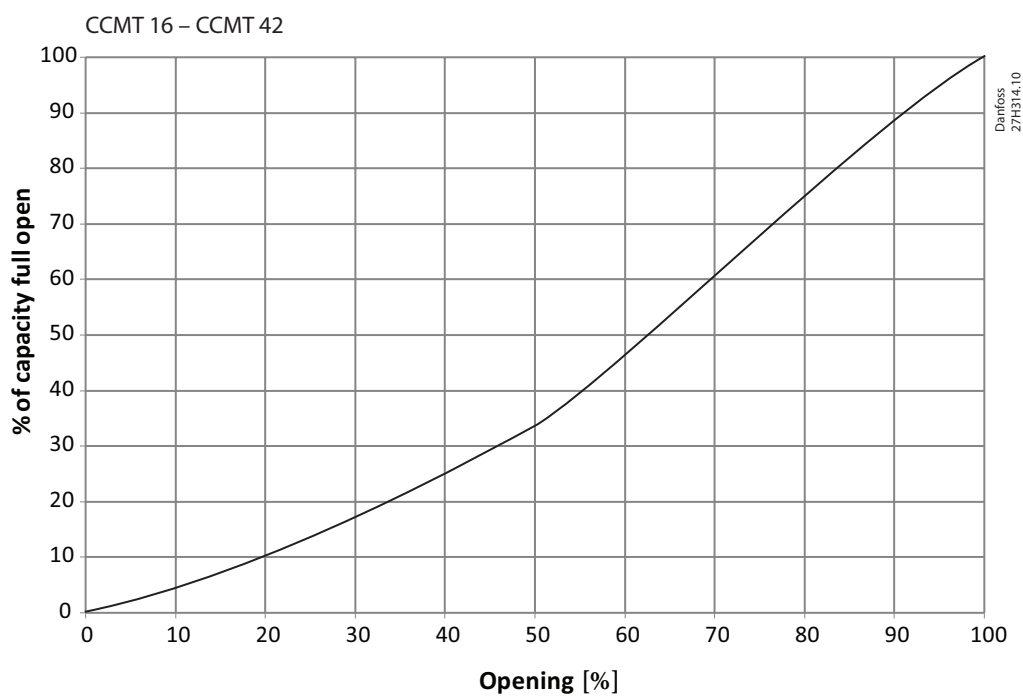
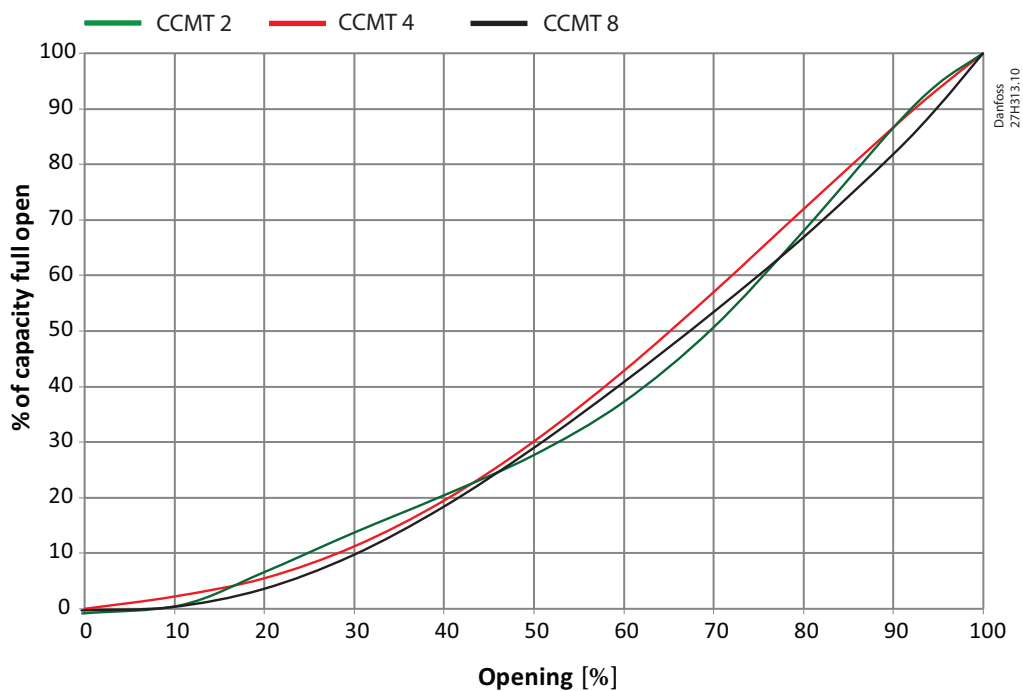

Dimension and weight

CCMT 2 – CCMT 8

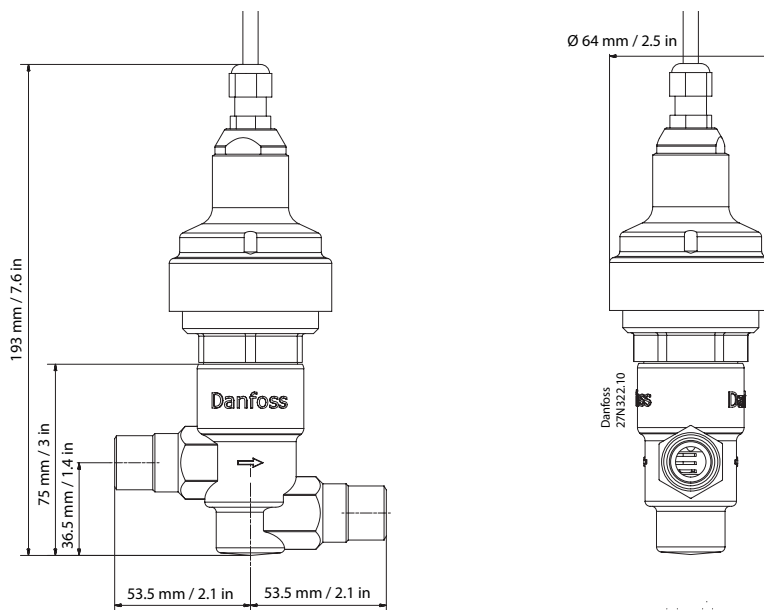

Weight:
1.5 kg / 3.3 lb

CCMT 16 – CCMT 42

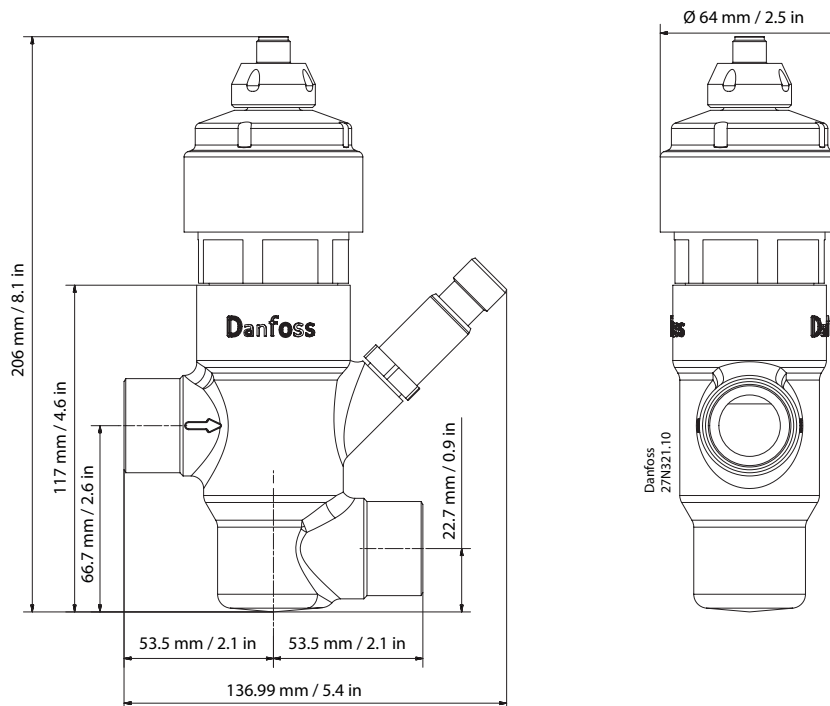

Weight:
2.6 kg / 5.7 lb

M12 female connector cable

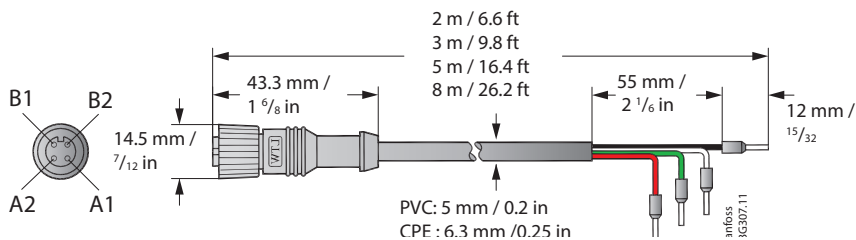

A1: White
A2: Black
B1: Red
B2: Green

ENGINEERING
TOMORROW



For further information please contact your local Danfoss sales office.

Danfoss can accept no responsibility for possible errors in catalogues, brochures and other printed material. Danfoss reserves the right to alter its products without notice. This also applies to products already on order provided that such alterations can be made without subsequential changes being necessary in specifications already agreed. All trademarks in this material are property of the respective companies. Danfoss and the Danfoss logotype are trademarks of Danfoss A/S. All rights reserved.