

Sample conditioning for kiln

## **SCK**

Sampling system for dry gas sampling  
at rotary cement kiln gas exit and calciner gas exit

### **System manual**

42/23-81 EN Rev. 4

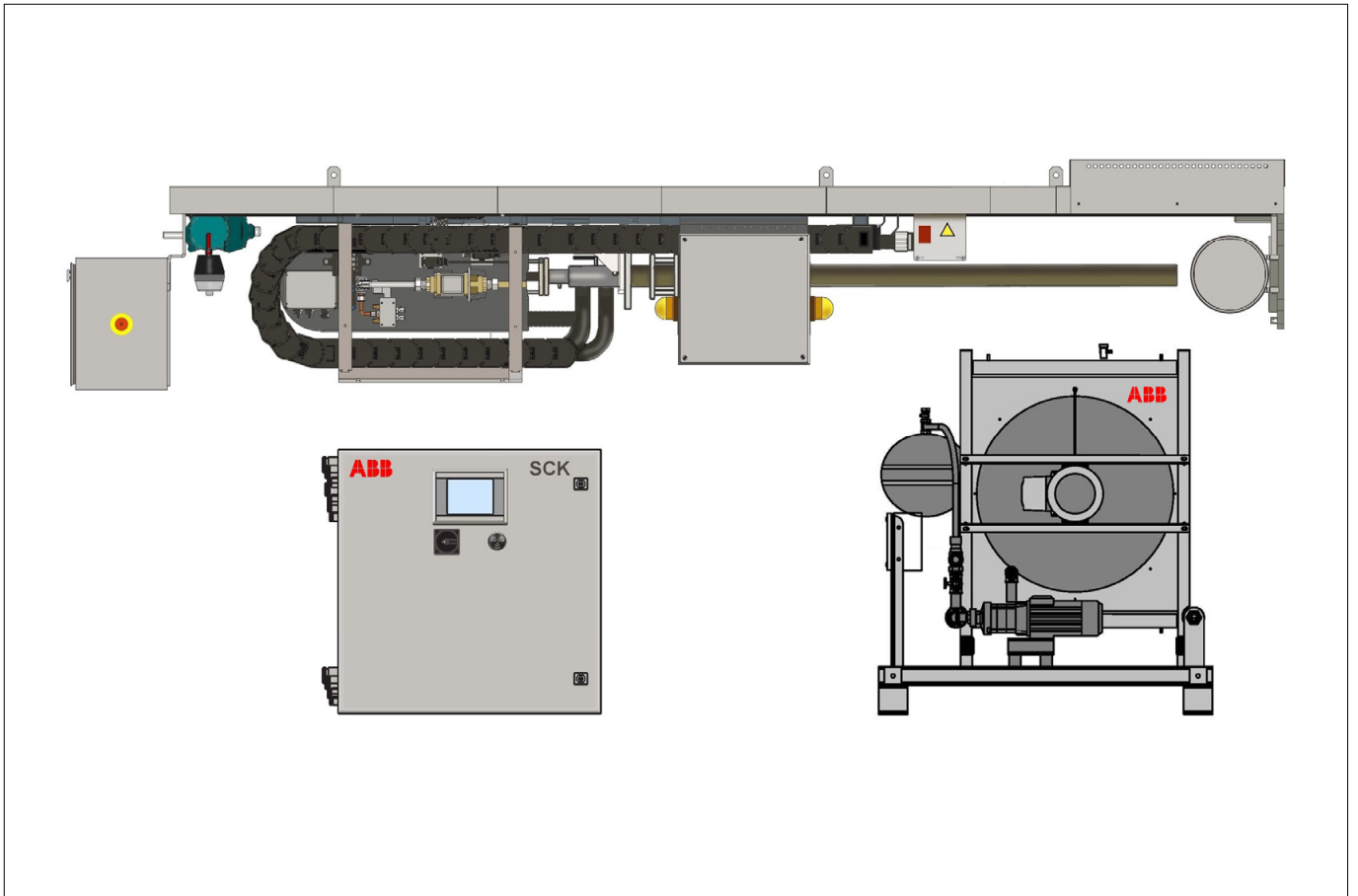



Sample conditioning for kiln

## **SCK**

Sampling system for dry gas sampling  
at rotary cement kiln gas exit and calciner gas exit

## **System manual**

Publication No. 42/23-81 EN

Revision 4

Edition November 2016

# Contents

<b>Chapter 1</b>	<b>General .....</b>	<b>7</b>
	About these operating instructions .....	8
	Safety instructions in this document .....	10
	System identification .....	12
	Service .....	15
<b>Chapter 2</b>	<b>Description of the sampling system .....</b>	<b>17</b>
	Technical data .....	18
	Intended conditions of use .....	19
	Structure and function .....	20
	Mode of functioning and operating modes .....	21
	Process monitoring .....	22
	Controls and displays .....	24
	Probe retractor .....	26
	Gas sampling probe H .....	28
	Gas sampling probe 60S .....	30
	Cooling module .....	32
	Transformer .....	34
	Compressed-air tank and pneumatic system .....	35
<b>Chapter 3</b>	<b>Description of control system .....</b>	<b>37</b>
	Structure and function of the control system .....	38
	User interface: Operation screen .....	40
	User interface: Trend screen .....	42
	User interface: Message screen .....	44
	User interface: Parameter screen .....	46
	Error message display .....	48
	Access permissions .....	49
	Default operating parameter settings .....	50
	Optimizing operating parameters .....	53
<b>Chapter 4</b>	<b>Safety .....</b>	<b>55</b>
	Basic safety rules .....	56
	Overview of dangers .....	58
	Protective installations .....	60
	Warning signs on the system .....	63
	Requirements to be met by personnel, work places .....	65
	Personal safety equipment .....	67
	Safety measures: Transport and unpacking .....	68
	Safety measures: Installation .....	69
	Safety measures: Start-up .....	72
	Safety measures: Operation .....	75
	Safety measures: Maintenance and troubleshooting .....	78
<b>Chapter 5</b>	<b>Transport and unpacking .....</b>	<b>83</b>
	General transport information .....	84
	Transport the system in the company .....	87
	Unpacking the system .....	89
	Scope of delivery .....	90

<b>Chapter 6</b>	<b>Installation</b> .....	<b>91</b>
	Overview: installation.....	92
	Checking site conditions.....	93
	Installing the probe retractor.....	95
	Installing the control cabinet.....	98
	Installing the compressed-air supply.....	99
	Installing the cooling module.....	101
	Installing the cooling water circuit.....	103
	Connecting the sample gas line to the retractor.....	104
	Connecting internal electric cables.....	105
	Connecting external electric cables.....	107
<b>Chapter 7</b>	<b>Start-up</b> .....	<b>111</b>
	Overview: Start-up.....	112
	Installation check.....	113
	Preparing the cooling-water circuit.....	114
	Preparing the compressed-air supply.....	116
	Activation.....	118
	After switching on: working on the cooling module.....	121
	Checking the pneumatic system.....	123
	Starting frequency converter and adapting control parameters.....	124
	Checking/correcting operating parameters.....	127
	Checks to perform when using probe H.....	128
	Inserting the probe and switching to automatic mode.....	131
<b>Chapter 8</b>	<b>Operation</b> .....	<b>135</b>
	Safety regulations for operation.....	136
	Monitoring automatic mode.....	138
	Checking general condition.....	140
	Cleaning gas sampling probe H.....	142
	Cleaning gas sampling probe 60S.....	144
	Using the EMERGENCY-STOP switch.....	146
<b>Chapter 9</b>	<b>Maintenance</b> .....	<b>147</b>
	Maintenance plan.....	148
	Equipment layout plan.....	152
	Acquiring spare parts and wear parts.....	155
	Safety regulations for maintenance work.....	156
	Operating the service switch.....	159
	Checking the condition of the system, cleaning the system.....	161
	Evaluating trend displays.....	164
	Checking the residual current circuit breaker.....	165
	Checking protective installations.....	167
	Checking for leaks.....	171
	Gas sampling probe H: Removing incrustations.....	174
	Gas sampling probe H: Replacing the intake filter.....	176
	Gas sampling probe H: Replacing membrane pump membranes.....	179
	Gas sampling probe 60S: Removing incrustations.....	182
	Gas sampling probe 60S: Cleaning or replacing the outlet filter.....	184
	Gas sampling probe 60S: Replacing the seal set.....	187
	Probe retractor: Checking filter/pressure control combination.....	189
	Probe retractor: Checking and replacing the filter muffler.....	191
	Probe retractor: Checking and topping up the oiler.....	193

	Probe retractor: Checking and tightening the drive chain .....	196
	Probe retractor: Checking and, if necessary, adjusting the position of the probe ..	198
	Probe retractor: Checking and, if necessary, adjusting the position indicator (probe end position).....	202
	Probe retractor: Checking the bellows .....	205
	Cooling module: Vent the cooling-water circuit .....	206
	Cooling module: Checking and topping up cooling water .....	208
	Pneumatic system: Replacing the compressed-air filter .....	211
<b>Chapter 10</b>	<b>Errors .....</b>	<b>213</b>
	Errors and irregularities .....	214
	Touchscreen error displays.....	216
	Handling error messages .....	221
<b>Chapter 11</b>	<b>Shutting down, storing, putting back into operation, disposal .....</b>	<b>223</b>
	Shutting down the system .....	224
	Disassembling the system.....	227
	Storing the system .....	229
	Putting the system back into operation .....	230
	Disposing of the system .....	231
<b>Chapter 12</b>	<b>Appendix .....</b>	<b>233</b>
	Pneumatic/hydraulic interface plan.....	234
	Electrical connection plan.....	236
	Transformer connection plan.....	238
<b>Index</b>	<b>239</b>	

<b>Topic</b>	<b>Page</b>
About these operating instructions .....	8
Safety instructions in this document.....	10
System identification.....	12
Service .....	15

## About these operating instructions

<b>Scope and purpose</b>	<p>These operating instructions apply to the SCK gas sampling system, product number: 23919.</p> <p>These operating instructions are intended to give all personnel handling the gas sampling system the information required to perform the following tasks correctly and safely:</p> <ul style="list-style-type: none"><li>▪ Transport at the company (for first-time delivery, relocation, storage, putting back into operation)</li><li>▪ Set-up, unpacking and connection</li><li>▪ Start-up</li><li>▪ Operation</li><li>▪ Diagnostics and troubleshooting</li><li>▪ Maintenance</li><li>▪ Shutting down, disassembly, putting back into operation, storage and disposal</li></ul>
<b>Target group</b>	<p>These operating instructions are intended for the following groups:</p> <ul style="list-style-type: none"><li>▪ Process engineers and design engineers (for preparation of the installation site)</li><li>▪ Transporter</li><li>▪ Assembly personnel</li><li>▪ Start-up personnel</li><li>▪ Operating personnel</li><li>▪ Maintenance personnel</li><li>▪ Storage personnel</li><li>▪ Disposal personnel</li></ul>
<b>Illustrations in the operating instructions</b>	<p>The illustrations in the operating instructions do not always depict the actual layout of a gas sampling system as delivered. Therefore, the drawings in the supplied system documentation are always authoritative.</p>
	<p>Failing to observe the information in this document can lead to a risk of damage to property, injuries or even death.</p> <p>In order to ensure safety, all personnel handling the gas sampling system must have read and understood the following sections of this document before commencing any work:</p> <ul style="list-style-type: none"><li>▪ the section on <i>Safety</i> on page 55</li><li>▪ the sections describing the work to be performed</li></ul>
<b>Copyright</b>	<p>The manufacturer retains copyright to these operating instructions:</p> <p>ABB Automation GmbH Geschäftsgebiet Analysetechnik Stierstädter Straße 5 60488 Frankfurt am Main GERMANY</p> <p>These operating instructions contain regulations and drawings of a technical nature that must not, either in part or in whole, be reproduced, disseminated or exploited for the purpose of competition or passed on to third parties without permission.</p>
<b>Liability</b>	<p>The manufacturer is not liable for damage and disruptions resulting from a failure to observe these operating instructions and other applicable documents.</p>



**Symbols and  
typefaces**



Identifies safety information to be heeded when handling the gas sampling system in order to avoid risks to the operator.



Identifies special information regarding handling of the gas sampling system as well as use of these operating instructions.

**1, 2, 3, ...**

Identifies reference numbers in the figures.

**Further information**

Further information on ABB Analytical products and services is available on the Internet at "<http://www.abb.com/analytical>".

## Safety instructions in this document

### What are safety instructions for?

Safety instructions are information intended to prevent physical injuries. Safety instructions contain the following information:

- Type of danger
- Possible consequences if you fail to observe the instruction
- Action to prevent physical injury

### Types of safety instruction

This document contains the following types of safety instruction:

Type of safety instruction	Description	Indicated by
Basic safety instructions	Generic safety instructions not pertaining to a particular task: <ul style="list-style-type: none"> <li>▪ They provide a general description of dangers and safety measures when handling the system.</li> <li>▪ They are intended to educate the operator about existing dangers and to instruct him in general safety behavior.</li> <li>▪ They are suitable for safety instruction of all personnel handling the gas sampling system.</li> </ul>	Indicated by the title of the section.
Safety regulations for specific sections	Safety instructions pertaining to all tasks described in this section	Indicated by the title of the section
Safety instructions at the beginning of an instruction	Safety instructions with specific instructions pertaining to the entire instruction	<div style="border: 1px solid black; padding: 2px; display: inline-block;">▲ DANGER</div> <div style="border: 1px solid black; padding: 2px; display: inline-block;">▲ WARNING</div> <div style="border: 1px solid black; padding: 2px; display: inline-block;">▲ CAUTION</div>
Safety instructions on a particular step	Safety instructions with specific instructions pertaining to one step only	<b>DANGER</b> <b>WARNING</b> <b>CAUTION</b>

## Danger levels

The safety instructions pertaining to instructions and actions are indicated by a danger word. The danger word stands for a particular danger level:

Type of safety instruction	If the instruction is not followed ...	And the consequence is ...
DANGER	an accident occurs.	serious bodily injury or death.
WARNING	the accident may occur.	possibly serious bodily injury or death.
CAUTION	the accident will definitely or may possibly occur.	major or minor bodily injury.

## Warning of damage to property

Warnings of possible damage to property are marked by the word **CAUTION** in this document if there is no danger of injury to persons.

# System identification

## Nameplate

The gas sampling system can be unambiguously identified by means of the specifications on the nameplate. The nameplate is located on the left side wall of the control cabinet. The nameplate is laid out as follows:

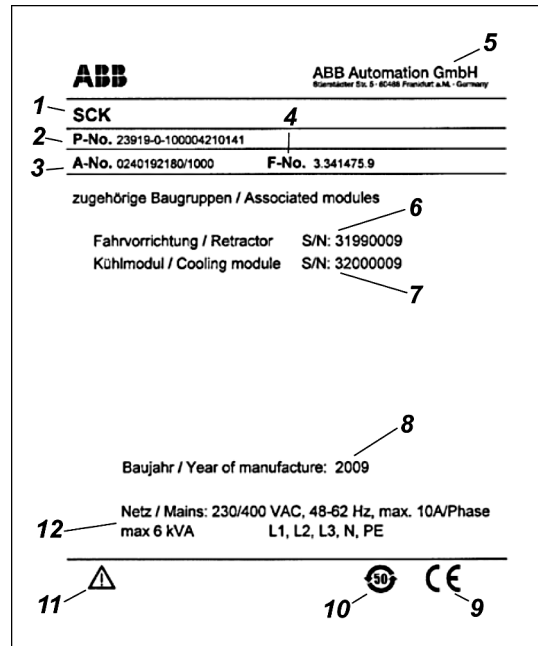

The individual areas of the nameplate have the following meaning:

No.	Meaning
<b>1</b>	Product name
<b>2</b>	Product number
<b>3</b>	Customer order number
<b>4</b>	Production number
<b>5</b>	Manufacturer's address
<b>6</b>	Serial number of the retractor
<b>7</b>	Serial number of the cooling module
<b>8</b>	Year of manufacture of the system
<b>9</b>	CE mark
<b>10</b>	Environment-Friendly Use Period (EFUP) mark
<b>11</b>	Warning triangle to DIN EN 61010: observe operating instructions
<b>12</b>	Electric connections

**Unique identification** The gas sampling system can be identified by means of the product number on the nameplate and the following table:

Product number 23919-0-	Value	Characteristic	Version
<b>1st digit</b>	<b>1</b>	Application	SCK
<b>2nd-4th digit</b>	<b>0</b>	n.a.	
<b>5th digit</b>	<b>0</b>	Compressed-air supply	w/o compressed-air tank
	<b>1</b>		with compressed-air tank
<b>6th digit</b>	<b>1</b>	Special type and length	60S; 1.5 m
	<b>2</b>		60S; 2 m
	<b>3</b>		60S; 2.5 m
	<b>4</b>		60S; 3 m
	<b>5</b>		60S; 3.5 m
	<b>6</b>		H; 1.5 m
	<b>7</b>		H; 2 m
	<b>8</b>		H; 2.5 m
	<b>9</b>		H; 3 m
	<b>A</b>		H; 3.5 m
<b>7th digit</b>	<b>1</b>	Retractor	Standard retractor 2.5 m
	<b>2</b>		Standard retractor 3.5 m
	<b>3</b>		Retractor with special length
<b>8th digit</b>	<b>1</b>	Sample gas line	prepared for TBL01-C
	<b>2</b>		prepared for heated sample gas line
	<b>3</b>		prepared for unheated sample gas line
<b>9th digit</b>	<b>0</b>	n.a.	
<b>10th digit</b>	<b>1</b>	Power supply	230 V/400 V, 50 Hz
	<b>2</b>		230 V/400 V, 60 Hz
	<b>3</b>		120 V/208 V, 60 Hz (incl. transformer)
	<b>4</b>		230 V/400 V, 50 Hz prep. for UPS
	<b>5</b>		230 V/400 V, 60 Hz prep. for UPS
	<b>6</b>		120 V/208 V, 60 Hz (incl. transformer) prep. for UPS
<b>11th digit</b>	<b>1</b>	External signal transfer	Status signals as relay contacts
	<b>2</b>		Profibus
	<b>3</b>		Signals as relay contacts + Profibus
	<b>4</b>		Connection to ACX via Modbus
	<b>5</b>		Connection to ACX + signals as relay contact
<b>12th digit</b>	<b>1</b>	Certificates	CE design
	<b>2</b>		CSA design

**Additional versions**

The following table sums up other product versions. These are not, however, coded in the product number.

<b>Characteristic</b>	<b>Versions</b>
Retractor, special length	(special) length of retractor according to customer requirement
Sturdy control unit	present/not present
Wire labeling	present/not present
Circuit breakers, 2-pole	present/not present
Residual current circuit breaker for entire system	present/not present
Cable labeling	present/not present
Engraved nameplates	present/not present
Additional nameplates (engraved)	No. 1 / 2 / 3 / 4 / 5
Orientation of probe S	Sampling holes to the right / to the left

## Service

### Service

Contact ABB Service in the following cases:

- if you have any questions regarding handling of the gas sampling system that are not dealt with in these operating instructions
- for ordering spare parts
- for ordering maintenance work

### Service address

Contact your local ABB Service representative. For emergencies, please contact:

ABB Service, Telephone: +49-(0)180-5-222580, Telefax: +49-(0)621-38193129031,  
E-Mail: [automation.service@de.abb.com](mailto:automation.service@de.abb.com)





<b>Topic</b>	<b>Page</b>
Technical data .....	18
Intended conditions of use.....	19
Structure and function.....	20
Mode of functioning and operating modes .....	21
Process monitoring.....	22
Controls and displays .....	24
Probe retractor.....	26
Gas sampling probe H.....	28
Gas sampling probe 60S .....	30
Cooling module.....	32
Transformer .....	34
Compressed-air tank and pneumatic system .....	35

## Technical data

### Sound emission

The following sound emission may be expected when operating the retractor and cooling module:

<b>Retractor sound emission</b>	approx. 89 dB(A)
<b>Cooling module sound emission</b>	approx. 89 dB(A)

### Dimensions and weights

The following table lists the dimensions and weights of the main modules of the gas sampling system:

#### Retractor:

<b>Dimensions</b>	Width 800 mm, Height 600 mm, Length 4500 / 5500 mm
<b>Weight</b>	450 / 500 kg

#### Probe H:

<b>Weight</b>	95 kg (for 3 m special length)
---------------	--------------------------------

#### Probe 60S:

<b>Weight</b>	45 kg (for 3 m special length)
---------------	--------------------------------

#### Control cabinet:

<b>Dimensions</b>	Width 800 mm, Height 1000 mm, Depth 300 mm
<b>Weight</b>	75 kg

#### Cooling module:

<b>Dimensions</b>	Width 1200 mm, Height 1500 mm, Depth 800 mm
<b>Weight</b>	250 kg

#### Transformer (optional):

<b>Dimensions</b>	Width 634 mm, Height 953 mm (with base and transport lugs), Depth 400 mm
<b>Weight</b>	140 kg

#### 250-l compressed-air tank (optional):

<b>Dimensions</b>	Height 1785 mm, Diameter 530 mm
<b>Weight</b>	140 kg

## Intended conditions of use

### **Purpose of the gas sampling probe**

The gas sampling system is used to monitor process gas in cement production.

The gas sampling system is used for continuous sampling of sample gas

- at primary firing at the gas outlet of the rotary kiln,
- at secondary firing at the gas outlet of the calcinator.

Analysis of the sample gas is by means of a suitable analyzer system, for example the ACX analysis system from ABB Automation GmbH.

### **Restrictions on use**

The gas sampling system may not be used

- to measure mixtures of gas/air or gas/oxygen that are capable of ignition during normal service,
- to measure flammable gas which may form an explosive mixture in combination with air or oxygen,
- in a potentially explosive atmosphere or in explosion-hazard areas,
- to measure extremely toxic or extremely corrosive gases.

## Structure and function

### Illustration

The following diagram shows an overview of the SCK modules:

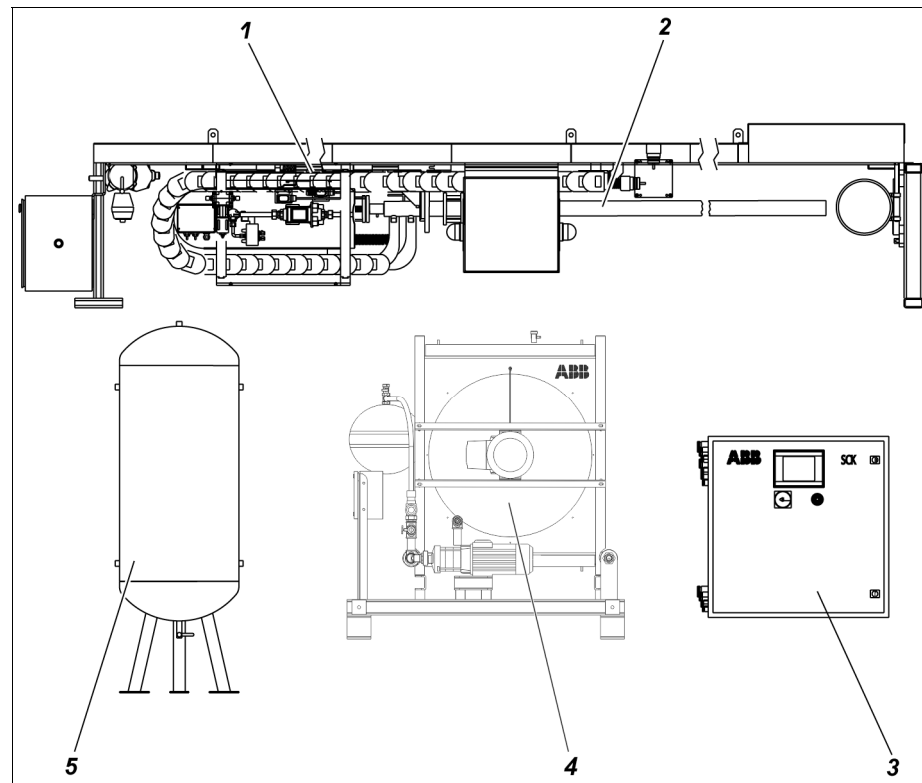

### Modules

The individual modules of the gas sampling system have the following functions:

No.	Designation	Function
1	Retractor	<ul style="list-style-type: none"> <li>▪ mechanical movement of the probe</li> <li>▪ automatic removal of the probe when malfunctions occur</li> </ul>
2	Gas sampling probe	<ul style="list-style-type: none"> <li>▪ sampling of sample gas from the process</li> </ul>
3	Control cabinet	<ul style="list-style-type: none"> <li>▪ control and monitoring</li> <li>▪ error display</li> </ul>
4	Cooling module	<ul style="list-style-type: none"> <li>▪ cooling of the gas sampling probe</li> </ul>
5	Compressed-air tank (optional)	<ul style="list-style-type: none"> <li>▪ back up probe movement if the on-site compressed-air supply fails</li> </ul>

### Additional explanations

The sampling system serves the purpose of continuous sampling of sample gas at the measuring point, i.e. at the gas outlet of the rotary kiln or at the gas outlet of the calcinator. The probe forms a unit with the pneumatic probe retractor. It is integrated in a closed cooling-water circuit with a heat exchanger (cooling module). The retractor and probe can be controlled from the touchscreen on the control cabinet. The sample gas is filtered in the probe and ducted into the sample gas line. Further conditioning and analysis of the gas takes place in external equipment (not part of the gas sampling system).

## Mode of functioning and operating modes

**Mode of functioning** The following process takes place in order to sample gas during cement production:

Phase	Description
1	The operator switches the system to manual mode.
2	The operator inserts the probe into the rotary kiln.
3	The cooling water is heated up to operating temperature.
4	Once the cooling water reaches the threshold temperature, the controller activates gas flow. <b>Result:</b> The gas sampling probe sucks the sample gas through the sample gas line and passes it on to the connected analysis system.
5	The operator switches to automatic mode.
6	The probe cleaning system cleans the probe after the set interval.
7	The retractor moves the probe in and out after a set interval in order to prevent it from sticking.

### Modes

The following modes are possible:

Mode	Description
Automatic mode	Allows continuous operation of the system for sample gas sampling. Probe cleaning steps take place after set intervals (these can be defined using the controller).
Manual mode	Allows operation of the system in manual mode, required for maintenance, for example.

## Process monitoring

### Monitoring devices

The process is monitored by the following devices:

Monitoring device	Purpose	Function
Inductive position indicator <i>Probe inserted</i>	<ul style="list-style-type: none"> <li>▪ Ensures that front end position is reached</li> <li>▪ Monitoring of probe travel time</li> </ul>	<ul style="list-style-type: none"> <li>▪ Locks various follow-up functions</li> <li>▪ Triggers the retraction program if probe travel time is exceeded</li> </ul>
Inductive position indicator <i>Probe retracted</i>	<ul style="list-style-type: none"> <li>▪ Ensures that rear end position is reached</li> <li>▪ Monitoring of probe travel time</li> </ul>	<ul style="list-style-type: none"> <li>▪ Locks various follow-up functions</li> <li>▪ Triggers the retraction program if probe travel time is exceeded</li> </ul>
Mechanical position indicator <i>Probe retracted</i>	<ul style="list-style-type: none"> <li>▪ Ensures that rear end position is reached</li> <li>▪ Monitoring of probe travel time</li> <li>▪ Additional signaling option for customer error management</li> </ul>	<ul style="list-style-type: none"> <li>▪ Locks various follow-up functions</li> <li>▪ Triggers the retraction program if probe travel time is exceeded</li> <li>▪ Provides a mechanical switching contact for error management</li> </ul>
Cooling water flow temperature measurement	<ul style="list-style-type: none"> <li>▪ Protects gas sampling probe against condensation build-up inside</li> </ul>	<ul style="list-style-type: none"> <li>▪ Locks various follow-up functions during start-up</li> </ul>
Cooling water pressure measurement	<ul style="list-style-type: none"> <li>▪ Protects the gas sampling probe against overheating</li> </ul>	<ul style="list-style-type: none"> <li>▪ Triggers the retraction program if minimum cooling water pressure is not reached</li> <li>▪ Cooling-water circuit leak monitoring</li> </ul>
Cooling water flow measurement	<ul style="list-style-type: none"> <li>▪ Protects the gas sampling probe against overheating</li> <li>▪ Monitors the cooling water pump for adequate pump power</li> </ul>	<ul style="list-style-type: none"> <li>▪ Triggers the retraction program if maximum cooling water temperature is exceeded</li> <li>▪ Cooling water pump function check</li> </ul>
Pressure switch <i>Compressed air</i>	<ul style="list-style-type: none"> <li>▪ Ensures adequate central compressed-air supply</li> </ul>	<ul style="list-style-type: none"> <li>▪ Triggers the retraction program if minimum input pressure is not reached</li> </ul>
Cooling water return temperature measurement	<ul style="list-style-type: none"> <li>▪ Protects the probe against overheating</li> </ul>	<ul style="list-style-type: none"> <li>▪ Triggers the retraction program if maximum temperature is exceeded</li> <li>▪ Locks follow-up functions</li> </ul>
Pressure switch <i>Emergency tank full (optional)</i>	<ul style="list-style-type: none"> <li>▪ Ensures adequate compressed-air reserve</li> </ul>	<ul style="list-style-type: none"> <li>▪ Triggers the retraction program if minimum input pressure is not reached</li> </ul>

<b>Monitoring device</b>	<b>Purpose</b>	<b>Function</b>
Reed contact <i>shutter open</i> (only for automatic shutter actuation)	<ul style="list-style-type: none"> <li>Protects the gas sampling probe against damage</li> </ul>	<ul style="list-style-type: none"> <li>Prevents insertion of the gas sampling probe if the shutter is not fully open</li> </ul>
Sample gas line temperature measurement	<ul style="list-style-type: none"> <li>Protects the sample gas line against condensation build-up inside</li> </ul>	<ul style="list-style-type: none"> <li>Prevents insertion of the gas sampling probe if the sample gas line is not fully heated up</li> </ul>
Cable drag chain temperature measurement	<ul style="list-style-type: none"> <li>Protects the cable drag chain against condensation build-up inside</li> </ul>	<ul style="list-style-type: none"> <li>Prevents insertion of the gas sampling probe if the sample gas line is not fully heated up</li> </ul>

#### Only for probe H

The following monitoring devices belong to the probe H only:

<b>Monitoring device</b>	<b>Purpose</b>	<b>Function</b>
Reed contact <i>plunger extended</i>	<ul style="list-style-type: none"> <li>Protects the plunger against overheating</li> </ul>	<ul style="list-style-type: none"> <li>Triggers the retraction program if end position is not reached</li> </ul>
Reed contact <i>plunger retracted</i>	<ul style="list-style-type: none"> <li>Protects the plunger against overheating</li> </ul>	<ul style="list-style-type: none"> <li>Triggers the retraction program if end position is not reached</li> </ul>

## Controls and displays

### Control cabinet

The control cabinet is the central control point of the sampling system. The electric power supply and signals for the entire sampling system are connected and distributed here. It contains the display and operating unit for monitoring and operating the system.

The control program is equipped with various locking mechanisms that prevent damage to the gas sampling probe due to incorrect operation or failure of individual modules. If not all locking conditions are met, operation is not possible. This safeguard is only overridden by personnel safety measures.

### Controls on the control cabinet

The picture shows controls on the control cabinet (side view left, front operating panel right):

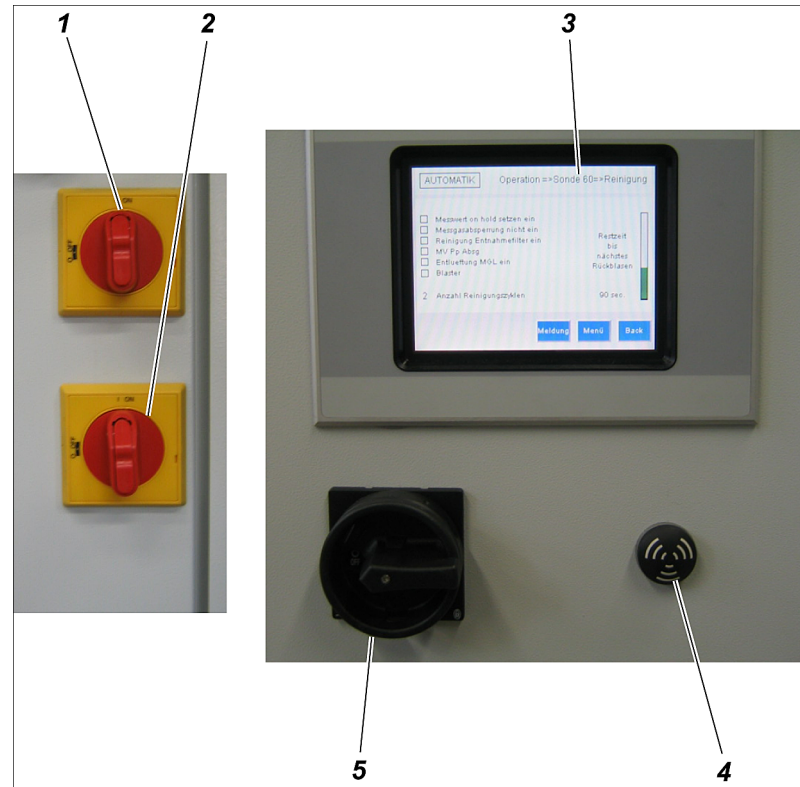

### Function of controls



The controls and displays on the control cabinet have the following function:

No.	Designation	Function
1	Main switch	▪ Switches power supply on and off
2	Uninterruptible power supply switch (optional)	▪ Switches uninterruptible power supply on and off
3	Touchscreen	▪ Display and operating unit for monitoring the system; for operation see <i>Description of the controller</i> on page 37
4	Warning buzzer	▪ See <i>Protective installations</i> on page 60
5	Service switch	▪ Puts the system into service mode ▪ Cancels service mode



## Other controls

There are additional controls and displays on the retractor:

Designation and illustration	Function
<p data-bbox="459 255 762 320">EMERGENCY STOP switch on pneumatic box</p> 	<ul style="list-style-type: none"><li data-bbox="791 255 1286 286">▪ see <i>Protective installations</i> on page 60</li></ul>
<p data-bbox="459 573 762 638">Warning lamps (2) on the terminal box</p> 	<ul style="list-style-type: none"><li data-bbox="791 573 1286 604">▪ see <i>Protective installations</i> on page 60</li></ul>

## Probe retractor

**Meaning** The probe retractor moves the up to 3.5 m long gas sampling probe. The drive is a pneumatic chain drive.

**Structure** The following illustration shows the probe retractor:

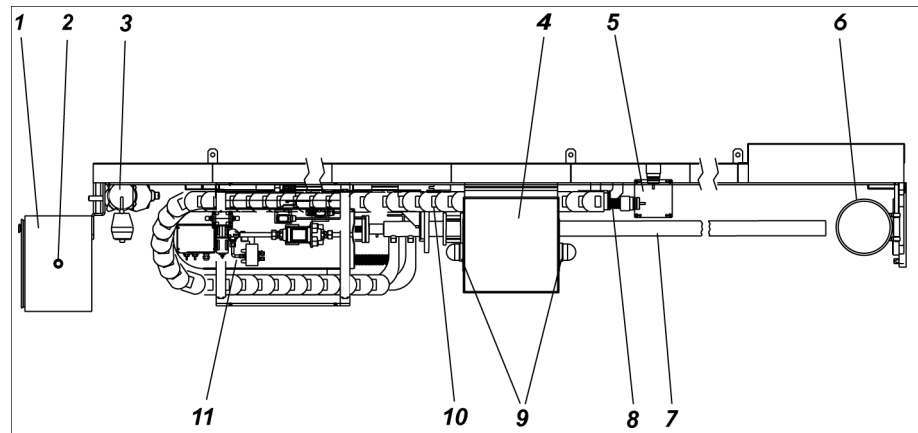

### Function of components

The main components of the probe retractor are:

No.	Component	Function
1	Pneumatic box	Central monitoring device to control compressed-air supply
2	EMERGENCY-STOP switch	Interrupts movement of the gas sampling probe.
3	Pneumatic motor	Ensures movement of the probe retractor.
4	Terminal box	Electric current connection.
5	Heated connection box ("cable drag chain")	Connection between the sample gas line of the gas sampling system and the downline sample gas line of the gas analysis system.
6	Shutter (with automatic [pneumatic] or manual actuation)	Closes the kiln duct opening when the probe is retracted.
<i>not illustrated</i>	Transport supports	For safe transport / storage of the retractor (removed in operation).
7	Gas sampling probe	For sampling sample gas.
8	Heated sample gas line	Transports the sample gas from the probe to the downline sample gas analysis system. Heating function prevents condensation from building up.
9	Warning lamps	Warn about insertion and retraction movements of the gas sampling probe.

No.	Component	Function
10	Energy chain	Guides pneumatic lines and electrical cables and the heated sample gas line and cooling water tubes.
11	Probe cleaning unit	Controls cleaning functions on the sample gas probe.

**Retraction in the event of malfunction**

The probe is automatically retracted if the following malfunctions occur:

- Cooling water temperature too high
- Cooling water flow rate too low
- Cooling water pressure too low
- Circulation pump failure
- Power supply interrupted
- Compressed air failure

**Shutter**

To protect the process against ambient air from being drawn in and to protect operators, the duct opening is closed by a shutter when the probe is retracted. This does not apply, however, to regular retraction/extension for cleaning the outside of the probe.

The shutter is moved either automatically by a pneumatic drive or manually.

**Supply lines**

The pneumatic/electric supply is connected at a central transition point. All required line connections are pre-installed in the probe retractor.

## Gas sampling probe H

**Meaning** The gas sampling probe H is used to sample the sample gas from the process.

**Structure** The following illustration shows the gas sampling probe H:

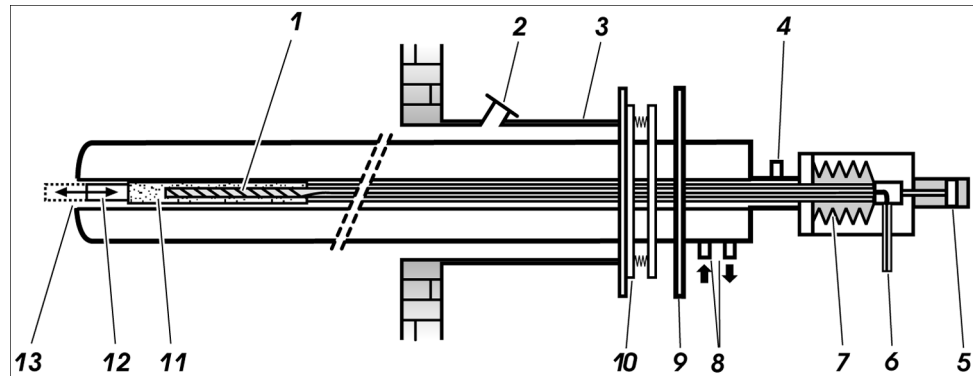

### Function of components

The main components of the gas sampling probe H are:

No.	Component	Function
1	Gas tube	Transports the sample gas through the probe to the gas outlet.
2	Connection for air cannon	Compressed-air blast from air cannon breaks up material deposits between the probe and the wall tube.
3	Wall tube	Pipe stub on rotary kiln.
4	Compressed air connection	Allows periodical cleaning of the filter with compressed air.
5	Compressed-air cylinder	Drives the plunger movement.
6	Gas outlet	Passes the sample gas to the down-line sample gas analysis system.
7	Bellows	Flexible sealing component between the outer fixed part of the probe and the moving plunger part.
8	Cooling water connections	Cooling water supply for probe cooling.
9	Mounting flange	For fastening the gas sampling probe to the retractor.
10	Pipe sealing device	Spring-mounted sealing of the wall tube.
11	Filter	Initial filtering of the sample gas for dust removal.
12	Plunger	Removes incrustations on the intake opening.
13	Sample gas intake opening	Sucks in the sample gas in the rotary kiln.

### Differences

Probe H is used when stubborn incrustations can be expected to build up on the probe due to the properties of the process and sampling conditions.

The two gas sampling probes H and 60S differ above all in the following:

	<b>Gas sampling probe H</b>	<b>Gas sampling probe 60S</b>
Cleaning procedure	Combined mechanical/pneumatic cleaning	Multi-stage pneumatic cleaning
Location of the filter element	Inner filter element	Outer filter element
Sampling holes	Front sampling hole	Side sampling hole

## Cleaning

Cleaning the gas sampling probe H comprises the following procedures:

<b>Cleaning procedure</b>	<b>Mode of functioning</b>
Cleaning of the wall tube	Compressed-air blast from air cannon removes material deposits between the probe and the wall tube.
Cleaning of the outside of the probe	Material deposits and incrustations on the probe are removed by regularly moving the probe in and out using the retractor.
Cleaning the probe intake hole by means of plunger movements	Incrustations on the intake hole are removed by periodical pneumatically controlled movements of the plunger.
Probe filter cleaning	Filter in probe pipe is cleaned periodically with compressed air.

## Gas sampling probe 60S

**Meaning** The gas sampling probe is used to sample the sample gas from the process.

**Layout** The following illustration shows the gas sampling probe 60S:

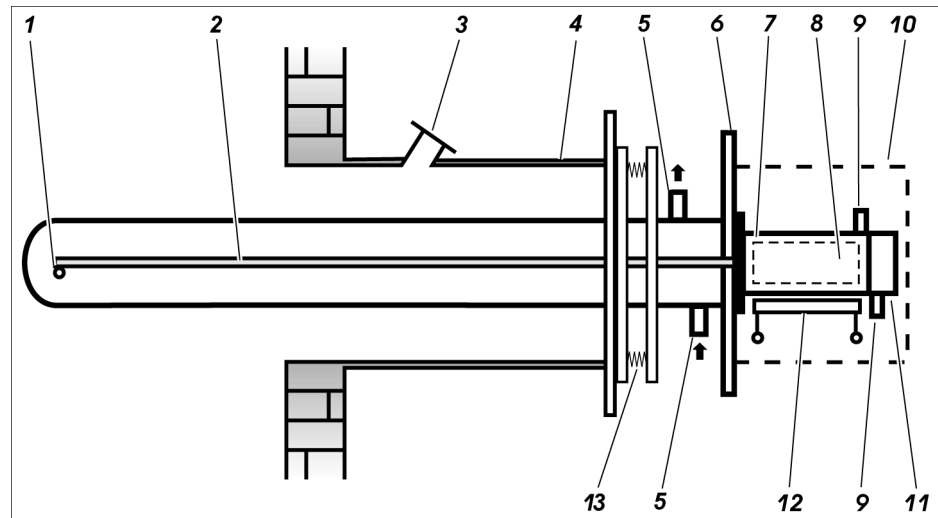

### Function of components

The main components of the gas sampling probe 60S are:

No.	Component	Function
1	Sample gas intake holes	Sucks in the sample gas in the kiln.
2	Gas tube	Transports the sample gas through the probe to the gas outlet.
3	Connection for air cannon	Compressed-air blast from air cannon breaks up material deposits between the probe and the wall tube.
4	Wall tube	Pipe stub on rotary kiln.
5	Cooling water connections	Cooling water supply for probe cooling.
6	Mounting flange	For fastening the gas sampling probe to the retractor.
7	Filter unit FE2	Initial filtering of the sample gas for dust removal.
8	Ceramic filter	
9	Compressed air connections	Allows periodical cleaning of the filter with compressed air.
10	Protective case	Filter unit casing.
11	Gas outlet	Passes the sample gas to the down-line sample gas analysis system.
12	Heating sleeve	Heats the filter unit to prevent condensation build-up.
13	Pipe sealing device	Spring-mounted sealing of the tube

## Differences

Probe 60S is used when stubborn incrustations are not expected to build up on the probe due to the properties of the process and sampling conditions.

The two water-cooled gas sampling probes H and 60S differ above all in the following:

	<b>Gas sampling probe H</b>	<b>Gas sampling probe 60S</b>
Cleaning procedure	Combined mechanical/pneumatic cleaning	Multi-stage pneumatic cleaning
Location of the filter element	Inner filter element	Outer filter element
Sampling holes	A front sampling hole	Two side sampling holes

## Cleaning

The gas sampling probe 60S offers the following cleaning procedures:

<b>Cleaning procedure</b>	<b>Mode of functioning</b>
Cleaning of the wall tube	Compressed-air blast from air cannon removes material deposits between the probe and the wall tube.
Cleaning of the outside of the probe	Material deposits and incrustations on the probe are removed by regularly moving the probe in and out using the retractor.
Probe filter cleaning	Filter in filter unit is cleaned periodically with compressed air.

# Cooling module

## Meaning

Owing to the prevailing operating conditions it is necessary to cool the gas sampling probe. The probe cooling system serves to provide and monitor the cooling water supply. In addition to the speed-controlled heat exchanger and cooling water transport unit, this unit also houses all transducers for monitoring cooling water. The completely closed system monitors the following parameters:

- Cooling water temperature
- Cooling water flow rate
- Cooling water pressure

## Structure

The following illustrations show the cooling module:

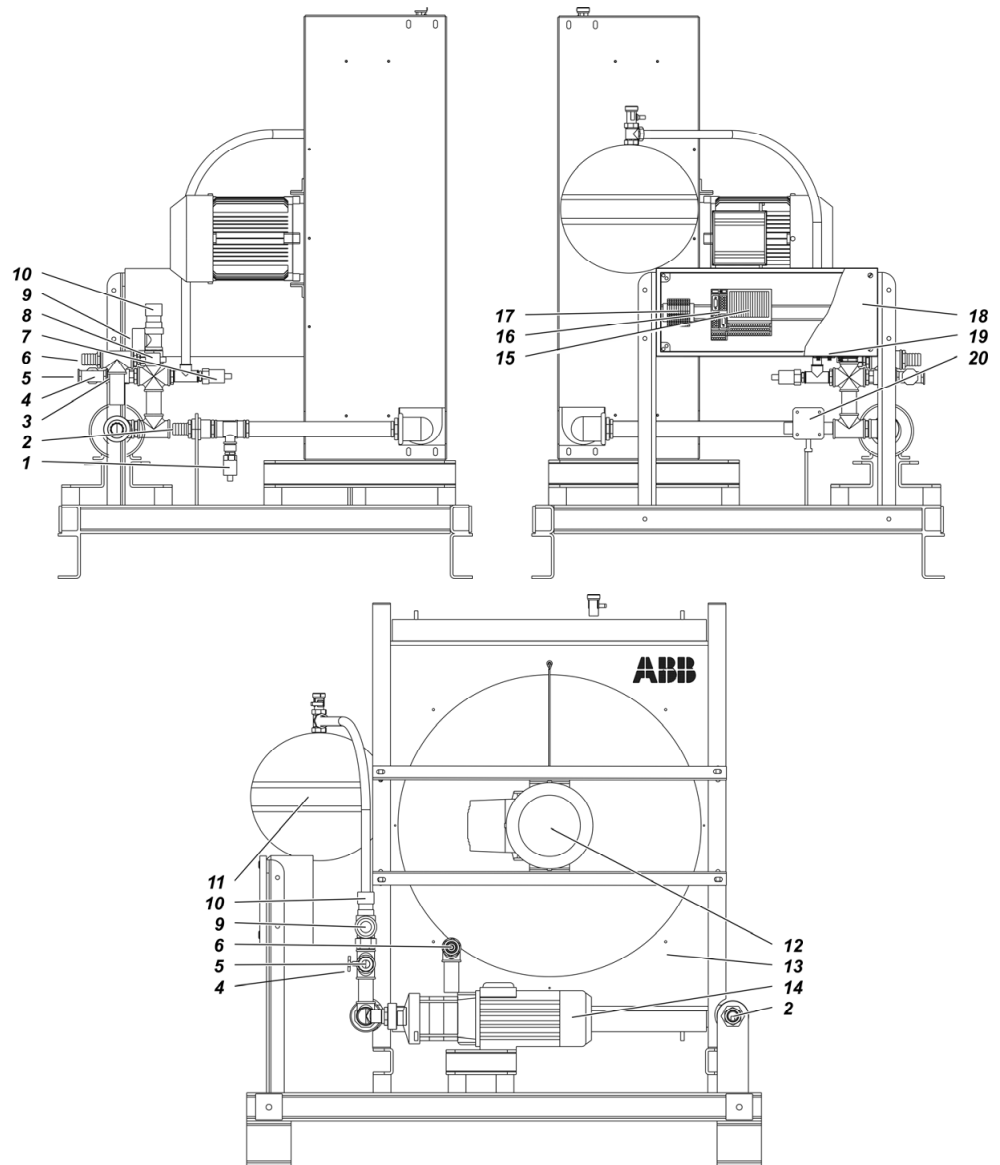



## Function of components

The main components of the cooling module are:

No.	Component
1	Temperature sensor (return) -B55
2	Cooling water return (brass, pipe connector 1")
3	Check valve -J65
4	Shut-off valve cooling water -J63
5	Cooling water inlet (brass, pipe connector 1")
6	Cooling water feed (brass, pipe connector 1")
7	Pressure controller -B56
8	Temperature sensor (feed) -B54
9	Safety relief valve outlet (brass, pipe connector 1")
10	Safety relief valve cooling water pressure -J62
11	Surge tank -J61
12	Fan motor heat exchanger -M52
13	Heat exchanger -J60
14	Cooling water pump -M51
15	Winbloc analog input module -D51
16	Winbloc CAN bridge -D50
17	Terminal strip power supply for motor and pump -X51
18	Terminal box -W51
19	Cable glands and cable feed-through
20	Flow controller -B57

## Cooling water circuit regulation

The closed cooling-water circuit must be filled with approx. 50 l potable water (requirements: see *Preparing the cooling-water circuit* on page 114). The circulation pump transports at least 5 m<sup>3</sup>/h through the probe pipe. The resistance thermometer is installed at the cooling water inlet of the cooling module and signals to the water temperature controller.

The water flows through the heat exchanger and pressure-compensating vessel. Additional instruments for measuring pressure, flow rate and temperature and fitted in the water pipe. Monitoring is performed on the touchscreen on the control cabinet.

## Transformer

### Transformer option

The gas sampling system can be fitted with a three-phase dry transformer (see *System identification* on page 12). The three-phase dry transformer is located in a sheet metal casing with door and base, wiring is by means of threaded connections. The casing is dip-impregnated to protect against moisture.

### Characteristics/ Design features

<b>Power</b>	6900.00 VA UL
<b>Primary voltage</b>	3 x 208 V (delta)
<b>Secondary voltage</b>	3 x 400 V (star)
<b>Degree of protection</b>	IP 54
<b>Test voltage</b>	4.0 kV
<b>Insulation category</b>	T 50/A
<b>Winding</b>	separate
<b>Protection class</b>	I
<b>Frequency</b>	60 Hz
<b>Switching</b>	YNd5
<b>PRI-/SEC connection</b>	Terminals with screw connection

## Compressed-air tank and pneumatic system

**Meaning** The compressed-air system serves to retract the probe out of the rotary kiln in the event of malfunctions, e.g. power supply failure. The compressed air is also used to clean the probe for certain types of probe.

**Requirements** The compressed air must meet the following minimum requirements:

Dew point	+3 °C
Pressure	6 bar (6000 hPa) positive pressure
Consumption	approx. 3 m <sup>3</sup> /h

One probe travel (2 x 20 s) requires approx. 1 m<sup>3</sup>.

Other requirements are:

- The compressed air must be free of dirt and oil/water droplets.
- At ambient temperatures below 0 °C make sure that the compressed-air supply cannot freeze.

### **Optional compressed-air tank**

The sampling system can be fitted with a 250-l compressed-air tank. The compressed-air tank serves to back up probe movement if the on-site compressed-air supply fails.

This tank is not required if the on-site compressed-air supply is of stable performance.



<b>Topic</b>	<b>Page</b>
Structure and function of the control system .....	38
User interface: Operation screen.....	40
User interface: Trend screen .....	42
User interface: Message screen.....	44
User interface: Parameter screen.....	46
Error message display .....	48
Access permissions .....	49
Default operating parameter settings .....	50
Optimizing operating parameters .....	53

## Structure and function of the control system

### What is the control system for?

The system is equipped with operating software operated from a touchscreen. It is located on the front of the control cabinet. The operator can select functions and configure settings from here. To select a function or configure settings, the operator simply touches the buttons with his finger.

### Structure

The following diagram depicts the menu structure. Only the first two of a maximum of four menu levels are shown.

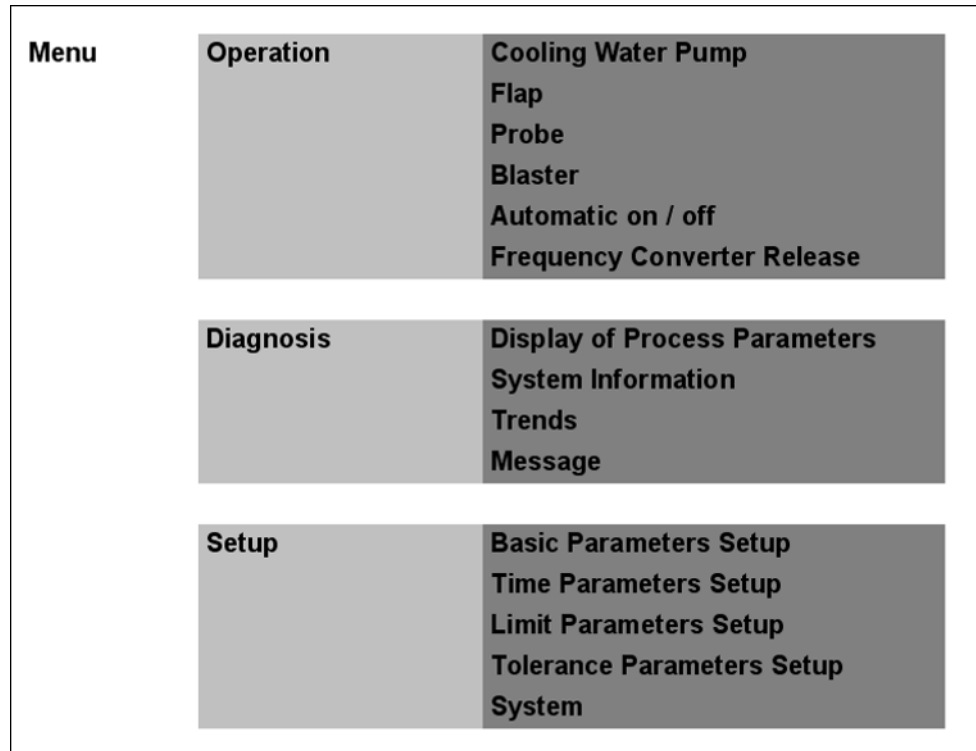

### Functions

The following table outlines the functions of the main menus:

Menu	Function
<b>Operation</b>	Operating functions for start-up, maintenance, etc.
<b>Diagnosis</b>	Displays current measured values, trend displays, messages and system information, etc.
<b>Setup</b>	Setup for system optimization (limits, etc.), access permissions, editing tolerance ranges, network settings, etc.

### Login

Authentication is performed on the **Login User** screen, that the operator accesses in the Start menu by pressing the **Menu** button and then **Login**. Without user authorization, the operator can only access the dialogs in the **Diagnosis** menu. For an overview of access permissions in the various areas of the control system, please refer to the section on *Access permission* on page 49.

### Navigation

The user navigates the interface in the bottom right corner of the screen. The **Menu** button goes back to the main menu, the **Back** button jumps to the previous

menu. Press the **Message** button to view the logbook containing all error messages, etc.

### **Data entry**

The menus of the operating software may contain pop-up menus with user prompts. We distinguish the following modes of data entry:

- Selection menus, e.g. to select a user name
- On/off buttons, e.g. to open and close the shutter
- Pop-up input panel (on-screen keyboard alphanumeric), e.g. to enter the user name
- Pop-up input panel (on-screen keyboard numeric), e.g. to enter the password

### **Screens**

The following list indicates the four basic screen types of the control system:

- *User interface: operating screen* on page 40
- *User interface: trend screen* on page 42
- *User interface: message screen* on page 44
- *User interface: parameter screen* on page 46

## User interface: Operation screen

### Illustration

This is a typical operation screen:

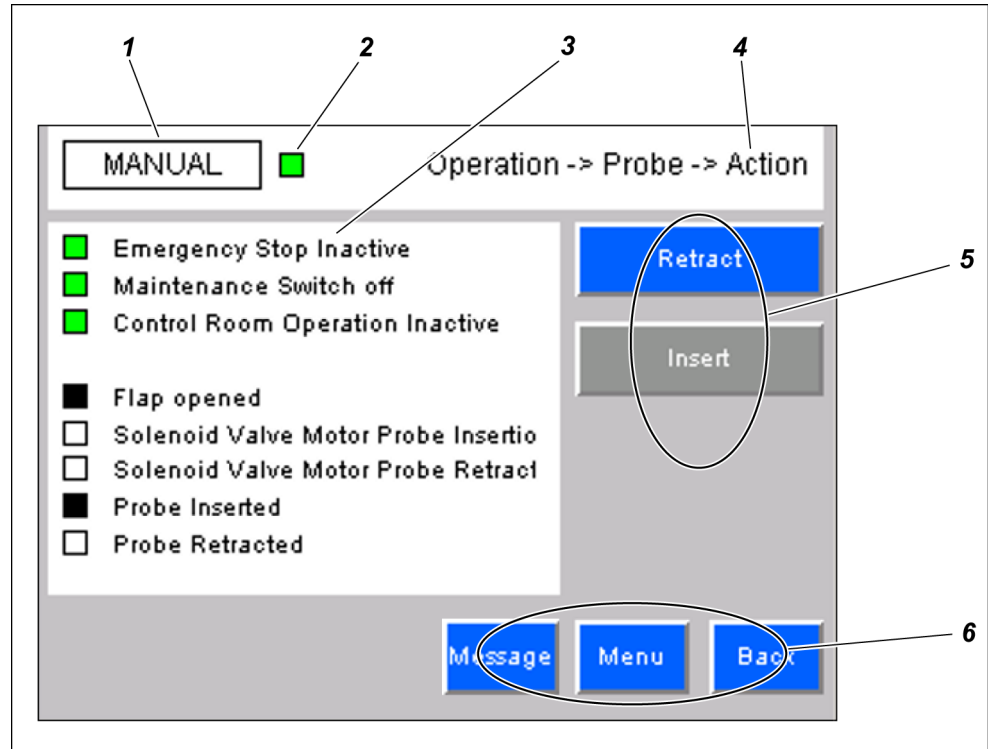







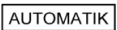

### Screen areas

The various areas of the screen have the following functions:

No.	Designation	Function
1	Mode	Displays the mode (AUTOMATIC, MANUAL)
2	System status lights	Displays the current system status (normal operation, error, maintenance requirement, maintenance)
3	Display area	Current menu display area
4	Current menu	Menu path display
5	Screen functions	Displays screen functions and submenus
6	Navigation area	Allows the following functions: <ul style="list-style-type: none"> <li>▪ jump to Message menu</li> <li>▪ jump to main menu</li> <li>▪ jump to previous menu</li> </ul>



**Buttons and symbols** The following table lists the buttons and displays in the user interface and their functions:

Symbol	Function
	Displays the mode (AUTOMATIC or MANUAL)
	System status lights: <ul style="list-style-type: none"> <li>green: normal operation</li> <li>red: error</li> <li>orange: maintenance required</li> <li>blue: maintenance</li> </ul>
Operation ->Blaster	Menu path display
	Display box: <ul style="list-style-type: none"> <li>white: requirement not met / process interrupted / inactive</li> <li>green: requirement met</li> <li>black: follow-up function / process running / active</li> </ul>
	Progress bar: time to next cleaning (only enabled in cleaning menus)
	Button to trigger a function associated with a control (button grayed-out if disabled)
	Jump to previous menu
	Jump to main menu
	Display Message menu

## User interface: Trend screen

### Illustration

This is a typical trend screen:

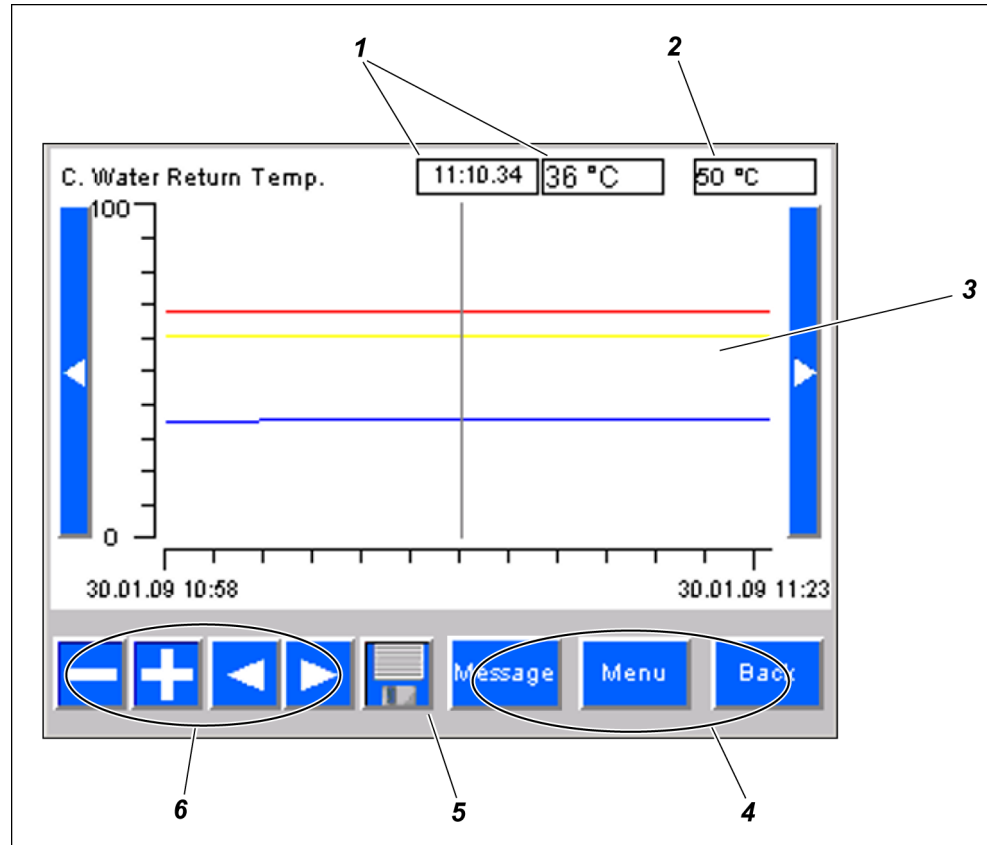







### Screen areas

The various areas of the screen have the following functions:

No.	Designation	Function
1	Measure value/time (reading rule)	indicates the measured value at the time defined by the reading rule
2	Current measured value	Current measured value
3	Display area	Displays measured values and alarm thresholds in the form of a line diagram
4	Navigation area	Allows the following functions: <ul style="list-style-type: none"> <li>▪ jump to Message menu</li> <li>▪ jump to main menu</li> <li>▪ jump to previous menu</li> </ul>
5	Save	Saves trend data
6	Diagram navigation	Allows you to zoom in/out in the line diagram and move the window currently displayed

**Buttons and symbols** The following table lists the buttons and displays in the user interface and their functions:

Symbol	Function
	Move the reading rule left/right in the diagram
	Jump to previous menu
	Jump to main menu
	Display Message menu
	Save contents: Save diagram data in xls format
	Move contents of window left/right
	Zoom in/out

**Colors** The following colors are used in the trend screen line diagram:

Color	Meaning
blue	Measured value
yellow	Pre-alarm
red	Main alarm

## User interface: Message screen

### Illustration

This is a typical message screen:

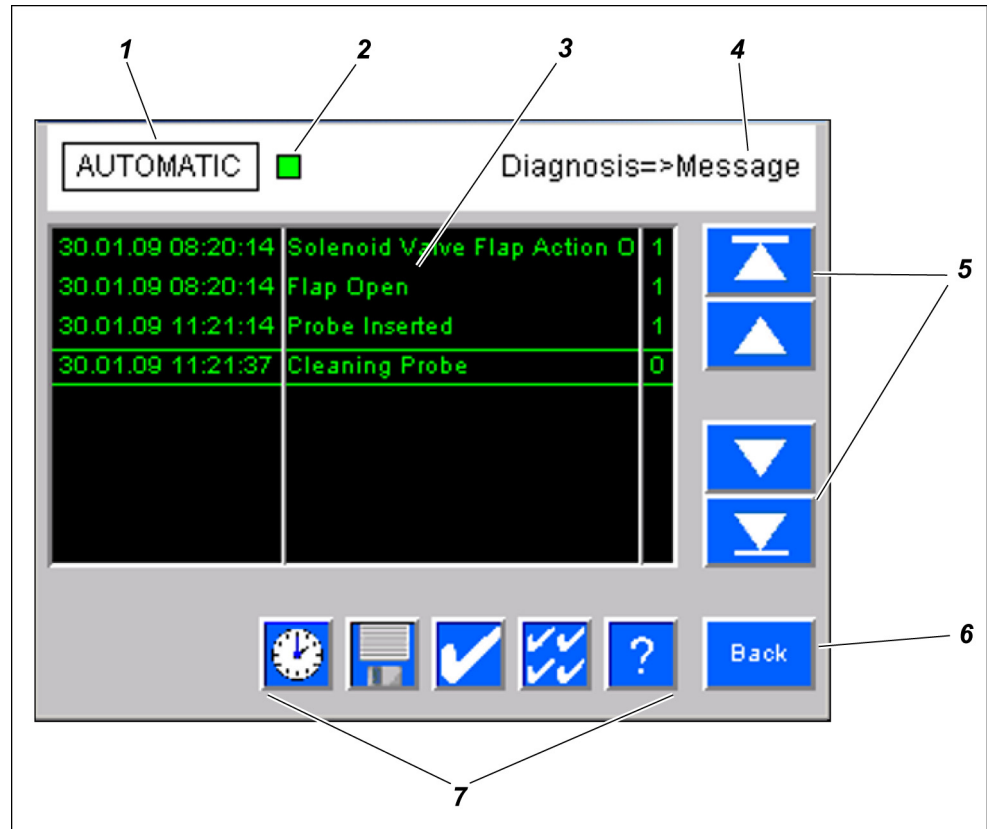







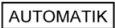

### Screen areas

The various areas of the screen have the following functions:

No.	Designation	Function
1	Mode	Displays the mode (AUTOMATIC, MANUAL)
2	System status lights	Displays the current system status (normal operation, error, maintenance requirement, maintenance)
3	Display area	Chronological list of messages with description of error and status
4	Current menu	Menu path display
5	Scrollbar	Scroll up and down in the logbook
6	Navigation area	Allows the following functions: <ul style="list-style-type: none"> <li>jump to previous menu</li> </ul>
7	Screen functions	Allows functions such as save history, reset message, etc. (see next page)

**Buttons and symbols** The following table lists the buttons and displays in the user interface and their functions:

Symbol	Function
	Displays the mode (AUTOMATIC or MANUAL)
	<p><i>System status lights:</i></p> <ul style="list-style-type: none"> <li>▪ green: normal operation</li> <li>▪ red: error</li> <li>▪ orange: maintenance required</li> <li>▪ blue: maintenance</li> </ul>
Operation ->Blaster	Menu path display
	Scroll buttons: scrolls logbook up/down and jumps to beginning/end
	Jump to previous menu
	Display help texts
	Reset all messages
	Reset the select message
	Save contents: Save messages in xls format
	<p>Display all messages in chronological order</p> <p>Click on crossed-out clock to display pending messages only</p>

**Colors** The following colors are used in the message screen display area:

Color	Meaning
green	Status message in normal operation
yellow	Maintenance required
red	Error message

## User interface: Parameter screen

### Illustration

This is a typical parameter screen:

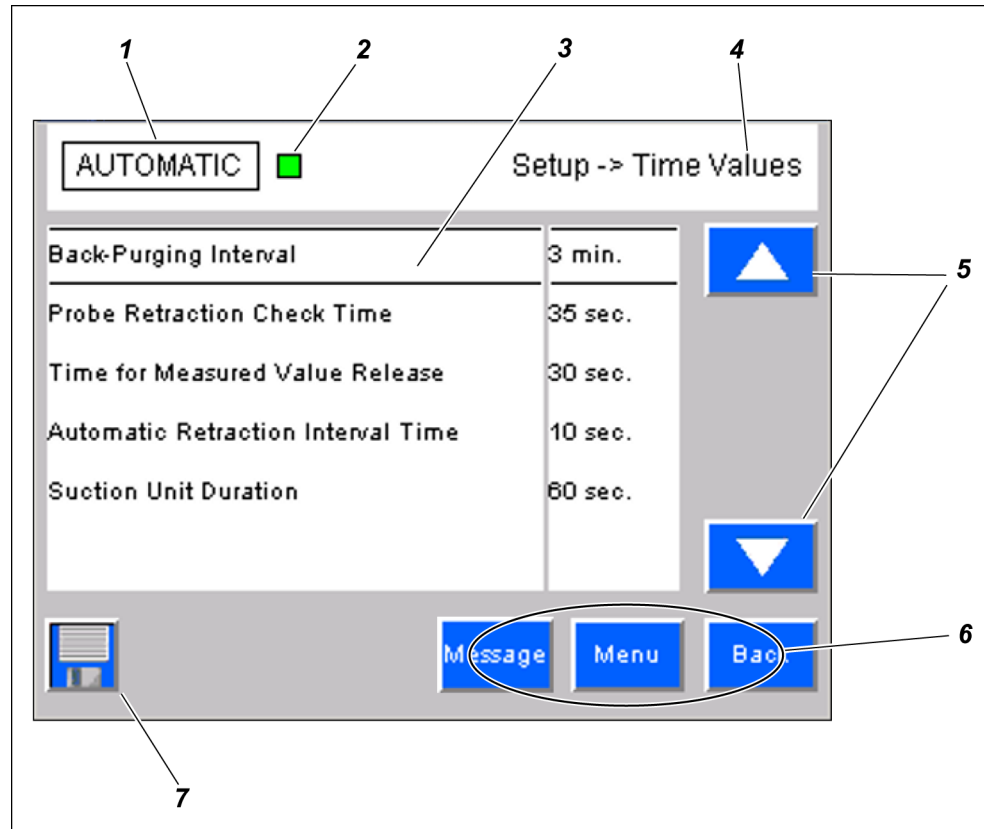





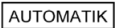

### Screen areas

The various areas of the screen have the following functions:

No.	Designation	Function
1	Mode	Displays the mode (AUTOMATIC, MANUAL)
2	System status lights	Displays the current system status (normal operation, error, maintenance requirement, maintenance)
3	Display area	List of parameters
4	Current menu	Menu path display
5	Screen navigation	Allows navigation in the parameter list
6	Navigation area	Allows the following functions: <ul style="list-style-type: none"> <li>▪ jump to Message menu</li> <li>▪ jump to main menu</li> <li>▪ jump to previous menu</li> </ul>
7	Save	Saves parameter settings

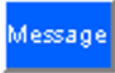
**Buttons and symbols** The following table lists the buttons and displays in the user interface and their functions:

Symbol	Function
	Displays the mode (AUTOMATIC or MANUAL)
	System status lights: <ul style="list-style-type: none"> <li>▪ green: normal operation</li> <li>▪ red: error</li> <li>▪ orange: maintenance required</li> <li>▪ blue: maintenance</li> </ul>
Operation ->Blaster	Menu path display
	Scroll up or down in the parameter list
	Jump to previous menu
	Jump to main menu
	Display Message menu
	Save contents: save parameter settings

**Edit parameters** The control system has factory settings that need to be modified to specific system conditions at start-up. You can edit alarm limits in a set range to suit specific system conditions. Touch a parameter entry to select it. The program displays an input box for you to input the appropriate value.

## Error message display

### Error display

Error messages are displayed on the touchscreen. All error messages are stored in the logbook (message screen). Touch the **Message** button on the interface to display this logbook. Refer to the section on *Errors* on page 213 for details on error messages and handling.



## Access permissions

### Password entry

The system controller has several access levels. They are enabled by entering a password.

### Hierarchy of access levels

The password levels are divided as follows.

	Level 1	Level 2	Level 3
Operation	<ul style="list-style-type: none"> <li>▪ Operating function for daily maintenance</li> </ul>	<ul style="list-style-type: none"> <li>▪ Operating function for start-up and periodical maintenance</li> <li>▪ Allows checking of control and monitoring functions</li> </ul>	
Diagnosis	<ul style="list-style-type: none"> <li>▪ Displays current measured values, messages</li> </ul>	<ul style="list-style-type: none"> <li>▪ Trend displays of internal measured quantities</li> <li>▪ Logbook</li> <li>▪ Reset messages</li> <li>▪ Special system information</li> </ul>	
Setup		<ul style="list-style-type: none"> <li>▪ Setup for system optimization (limits, etc.)</li> </ul>	<ul style="list-style-type: none"> <li>▪ Access permissions</li> <li>▪ Edit tolerance ranges</li> <li>▪ Network settings</li> </ul>



A higher access level always includes the permissions of the lower access levels.

### Comment on password level 3

In level 3 you can configure parameters that may result in functional impairment of the system. Changes in these access areas may only be performed by experienced skilled personnel with ABB certification as level-2 service technician. Always be extremely careful to whom you disclose the password for this level.

### Password in delivered state

In the delivered state, the following passwords are stored in the system:

**Level 1**    1111

**Level 2**    2020

**Level 3**    only handed out after completing level-2 service technician training

## Default operating parameter settings

### Time parameters

The control system has the following factory settings that need to be modified to specific system conditions at start-up.

<b>Parameter</b>	<b>Default</b>
<i>Back-Purging Interval</i>	3 min
<i>Probe Retraction Check Time</i>	90 s
<i>Time for Measured Value Release</i>	100 s
<i>Automatic Retraction Interval Time</i>	30 s
<i>Suction Unit Duration</i>	60 s

**Limit parameters**

The control system has the following factory settings that need to be modified to specific system conditions at start-up:

<b>Parameter</b>	<b>Default</b>	<b>Tolerance range</b>
<i>C. Water Flow Temp. MIN</i>	10 °C	5–25 °C
<i>C. Water Flow Temp. MAX</i>	80 °C	40–90 °C
<i>C. Water Return Temp. MAX</i>	85 °C	40–135 °C
<i>C. Water Return Temp. MAX2</i>	95 °C	90–100 °C
<i>C. Water Flow Rate MIN</i>	12 l/min	5–45 l/min
<i>C. Water Flow Rate MIN2</i>	11 l/min	1–35 l/min
<i>C. Water Pressure MIN</i>	350 mbar	300–900 mbar
<i>C. Water Pressure MIN2</i>	150 mbar	50–600 mbar
<i>C. Water Pressure MAX</i>	2500 mbar	2250–2750 mbar
<i>C. Water Flow / Return Temp. Diff.</i>	2 °C	1–15 °C
<i>Probe Heating Temp. MIN</i>	5 °C	1–100 °C
<i>Probe Heating Temp. MAX</i>	190 °C	30–200 °C
<i>Sample Gas Probe Pressure</i> (indicated only when SCK is connected to the ACX analysis system)	600 mbar	250–900 mbar

**Basic parameters**

The control system has the following factory settings that need to be modified to specific system conditions at start-up:

<b>Parameter</b>	<b>Default</b>	<b>Tolerance range</b>
<i>Action / Cleaning Cycle Ratio</i>	3	
<i>C. Water Return Temp. Set Point</i>	80 °C	15–140 °C
<i>Probe Heating Temp. Set Point</i>	100 °C	1–190 °C

## Optimizing operating parameters

### Introduction

The control system has factory settings that need to be modified to specific system conditions at start-up. You can edit alarm limits in a set range to suit specific system conditions. Limited configuration serves to protect the probe retractor against harmful or contradictory settings. A list of operating parameters with defaults can be found in *Default operating parameter settings* on page 50.

### Access levels

A password for a certain access level is required to edit parameters:

	Level 1	Level 2	Level 3
Edit time values		X	X
Edit limits		X	X
Edit basic values		X	X

### Edit time values

Proceed as follows to edit a time parameter:

Step	Procedure
1	Open the <i>Time Values</i> parameter screen. <b>Path:</b> Setup ► Time Parameters
2	Select parameter and enter appropriate value in the input box. <b>Note:</b> You can only edit time values within the tolerance limits.
3	Click the <b>Save</b> button to save the settings.

### Edit limit values

Proceed as follows to edit a limit parameter:

Step	Procedure
1	Open the <i>Alarm Values</i> parameter screen. <b>Path:</b> Setup ► Limit Parameters
2	Select parameter and enter appropriate value in the input box. <b>Note:</b> You can only edit limits within the tolerance limits.
3	Click the <b>Save</b> button to save the settings.

### Edit basic values

Proceed as follows to edit a basic parameter:

Step	Procedure
1	Open the <i>Basic Values</i> parameter screen. <b>Path:</b> Setup ► Basic Parameters
2	Select parameter and enter appropriate value in the input box. <b>Note:</b> You can only edit basic values within the tolerance limits.
3	Click the <b>Save</b> button to save the settings.



<b>Topic</b>	<b>Page</b>
Basic safety rules .....	56
Overview of dangers.....	58
Protective installations .....	60
Warning signs on the system .....	63
Requirements to be met by personnel, work places .....	65
Personal safety equipment.....	67
Safety measures: Transport and unpacking.....	68
Safety measures: Installation .....	69
Safety measures: Start-up .....	72
Safety measures: Operation.....	75
Safety measures: Maintenance and troubleshooting .....	78

## Basic safety rules

<b>Target group for these rules</b>	These rules are intended for all persons handling the gas sampling system.
<b>Purpose of these rules</b>	The purpose of these rules is to ensure that all persons handling the gas sampling system are thoroughly informed about risks and safety measures and that they observe the safety instructions in the operating instructions and on the system. Failing to observe these rules can lead to a risk of damage to property, injuries or even death.
<b>Handling the operating instructions</b>	Observe the following rules: <ul style="list-style-type: none"><li>▪ Completely read through the Safety section and the sections pertaining to your work. You must have understood these sections.</li><li>▪ Always keep the operating instructions handy nearby the gas sampling system for reference.</li><li>▪ Pass on the operating instructions if the gas sampling system is re-sold.</li></ul>
<b>Handling the gas sampling system</b>	Observe the following rules: <ul style="list-style-type: none"><li>▪ Only persons fulfilling the requirements specified in these operating instructions may handle the gas sampling system.</li><li>▪ The gas sampling system may only be used for the intended purpose. Never use the gas sampling system for any other purposes, even if they appear reasonable.</li><li>▪ Take all safety measures specified in these operating instructions and on the system. Specifically, use the prescribed personal safety equipment.</li><li>▪ Only work in the designated work areas.</li><li>▪ Do not make any modifications to the gas sampling system, e.g. by removing parts or attaching non-approved parts. Specifically, do not change or disable any protective installations.</li><li>▪ Use only original spare parts when replacing defective components.</li><li>▪ The gas sampling system may only be operated if maintenance work is performed regularly and expertly.</li></ul>
<b>Operator's obligations towards personnel</b>	The operator must ensure <ul style="list-style-type: none"><li>▪ that personnel meets the requirements for their tasks.</li><li>▪ that personnel is provided with the personal safety equipment specified in these operating instructions and, if necessary, additional safety equipment against risks posed by the installation site, e.g. by noise.</li><li>▪ that personnel is provided with maintenance equipment in order to secure the service switch, e.g. padlocks.</li><li>▪ that the system has protection against restarting the power supply in order to ensure that the system is powered off when the main switch is switched off.</li><li>▪ to prevent unauthorized activation of the power supply.</li><li>▪ that personnel have read and understood these operating instructions before they handle the gas sampling system.</li><li>▪ that personnel is regularly and recurrently instructed about the risks and safety measures when handling the gas sampling system.</li><li>▪ that the work areas of the gas sampling system are adequately aired and illuminated.</li><li>▪ that the safety regulations in force in your country are observed.</li><li>▪ that the safety regulations pertaining to setting up and operating electrical equipment in force in your country are observed.</li></ul>



- that the safety regulations pertaining to handling gases, lubricants, etc. in force in your country are observed.

**Procedure in the event of accidents**

The gas sampling system is designed and built in such a way that personnel can work with it without any risk. Despite all precautions, however, unforeseeable accidents may nevertheless occur in unfavorable circumstances. If cooling water pipes or compressed-air pipes burst, shut down the gas sampling system and secure it against being switched on again. If errors are detected, shut down the system and secure it against being switched on again. Before approaching the gas sampling system, wait until the entire cooling water or the entire compressed air has been evacuated.

If the switched-on gas sampling system poses a danger, proceed as follows:

Aim	Action
Stop movement of the system	Press the EMERGENCY-STOP switch <b>Note:</b> The gas sampling probe interrupts its movement immediately and in any position. The probe is only retracted out of the rotary kiln after pressing the service switch.
Disconnect the system from the mains	Turn off the main switch
Evacuate the compressed-air system	Close the stop valve in the pneumatic box

**If risk-free operation is no longer possible**

If it can be assumed that safe operation is no longer possible, the gas sampling system must be taken out of operation and secured against being started up again. It can be assumed that safe operation is no longer possible:

- if the gas sampling system is visibly seriously damaged,
- If the gas sampling system no longer works,
- after prolonged storage under adverse conditions,
- after severe transport stress.

**Further information**

*Intended Conditions of Use* on page 19  
*Overview of dangers* on page 58  
*Requirements to be met by personnel, work places* on page 65  
*Personal safety equipment* on page 67  
*Protective installations* on page 60  
*Safety measures: transport and unpacking* on page 68  
*Safety measures: installation* on page 69  
*Safety measures: start-up* on page 72  
*Safety measures: operation* on page 75  
*Safety measures: maintenance and troubleshooting* on page 78

## Overview of dangers

<b>Meaning</b>	<p>The gas sampling system is designed such that the operator is protected against all dangers that can be reasonably avoided by means of design.</p> <p>Due to the purpose of the gas sampling system, however, there are nevertheless residual risks that require precautions to be avoided.</p> <p>The following section gives information about the nature of these residual risks and their effect.</p>
<b>Moving gas sampling probe</b>	<p>The gas sampling probe moves in and out automatically. Expect a system-actuated movement of the gas sampling probe at any time. The gas sampling probe not only performs individual extension and retraction movements but also performs combined processes involving successive extension and retraction movements. This means:</p> <ul style="list-style-type: none"><li>▪ risk of injury due to automatic extension and retraction movements of the gas sampling probe if anyone is standing in the retractor's area of travel.</li><li>▪ danger of toxic, harmful gases when the shutter is open.</li></ul>
<b>Current-carrying components</b>	<p>The gas sampling system contains current-carrying components. This means:</p> <ul style="list-style-type: none"><li>▪ danger of electrocution,<ul style="list-style-type: none"><li>▪ If covers on control cabinet, terminal box or power connection are open. Connectors in the control cabinet or terminal box may also carry current.</li><li>▪ If the connection between the protective earth connector and a protective earth conductor is not made before all other connections.</li><li>▪ If the protective earth conductor is interrupted inside or outside the gas sampling system or the protective earth connector is disconnected.</li><li>▪ If the set operating voltage and mains voltage do not match before switching on.</li><li>▪ If work is performed on the open gas sampling system without disconnecting the gas sampling system from the power supply.</li><li>▪ Due to charged capacitors in the gas sampling system even if the gas sampling system has been disconnected from all sources of power.</li><li>▪ Due to fuses that do not match the specified type and nominal current and repaired fuses.</li></ul></li></ul>
<b>Hot surfaces</b>	<p>During operation of the gas sampling system surfaces and parts get hot. This means:</p> <ul style="list-style-type: none"><li>▪ Danger of burning due to hot surfaces during and after operation of the system.</li></ul>
<b>Harmful gases at the duct opening</b>	<p>When the shutter is open, gases flow out of the rotary kiln duct opening that may be harmful to health. This means:</p> <ul style="list-style-type: none"><li>▪ Danger of poisoning due to harmful gases.</li><li>▪ Danger of burning due to jets of flame at the duct opening.</li></ul>
<b>Hot cooling water</b>	<p>During operation of the gas sampling system, the cooling water in the cooling system gets very hot. This means:</p> <ul style="list-style-type: none"><li>▪ Danger of scalding in the event of contact with the hot cooling water.</li><li>▪ Danger of burning in the event of contact with the cooling water pipes.</li></ul>
<b>Anti-freeze in the cooling water</b>	<p>The cooling system contains cooling water with anti-freeze. This means:</p> <ul style="list-style-type: none"><li>▪ Danger of injury to skin and eyes in the event of contact with anti-freeze.</li></ul>

**Lubricating oil in the pneumatic module**

There may be lubricating oil in the pneumatic box, on the pneumatic motor filter muffler, and inside the pneumatic motor. This means:

- Danger of injury to skin and eyes in the event of contact with lubricating oil.

**Compressed air in the pneumatic system**

The pneumatic system contains compressed air. This means

- Danger of eye injuries if compressed air escapes, e.g. if compressed-air pipes burst, when opening screw connections or inadvertently opening compressed-air pipes with no additional connector.

## Protective installations

### Meaning

The gas sampling system is fitted with protective installations to protect the operator. All protective installations must be in place and operational during operation. The protective installations must not be disabled and must be checked for proper functioning at regular intervals.

### Illustration

The illustrations show the location of the protective installations on the gas sampling system.

Front view of the gas sampling system:

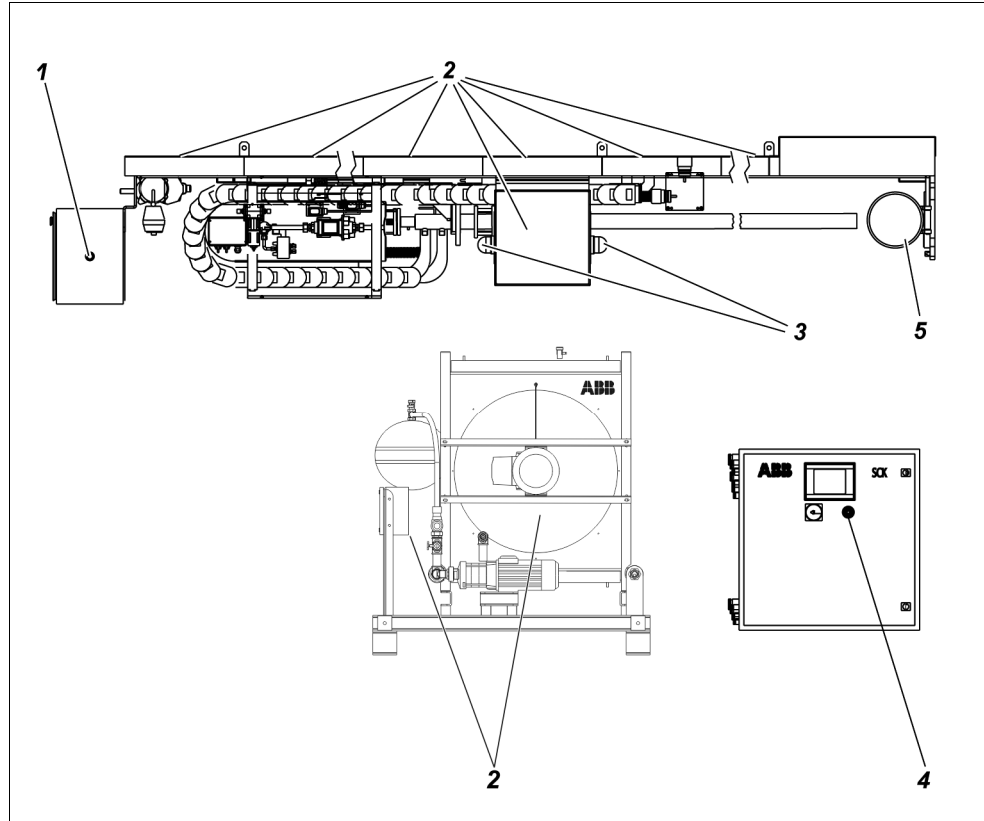

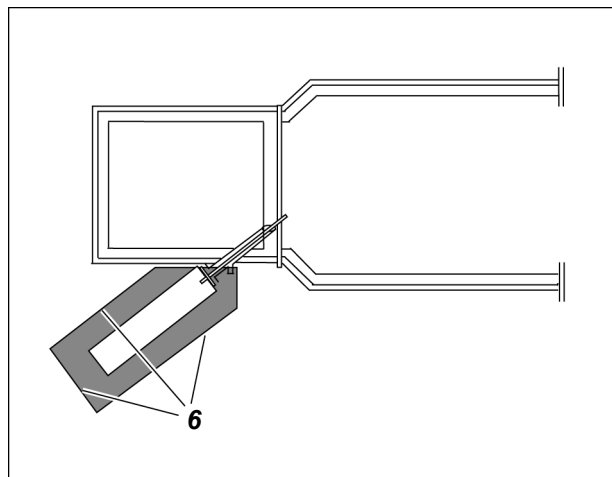

Top view of the rotary kiln with installed gas sampling probe and the danger zone around the probe retractor, which is secured by a protective installation (6).



**Protective installations**

The protective installations have the following function:

No.	Designation and photo	Location	Function
1	EMERGENCY-STOP switch 	Pneumatic box of the retractor	Interrupts movement of the gas sampling probe. The gas sampling probe can only move again when the EMERGENCY-STOP switch is unlocked and reset by pressing the service switch.
2	Covers	<ul style="list-style-type: none"> <li>▪ Retractor</li> <li>▪ Cooling module: rotor</li> <li>▪ Cooling module: Terminal box for electrical connections</li> </ul>	Protection from inserting hand into the system.
3	Warning lamps 	Retractor terminal box	Warn about probe movement.  The warning lamps flash in the following situations: <ul style="list-style-type: none"> <li>▪ Automatic mode: approx. 20 seconds before probe movement</li> <li>▪ Manual mode: immediately after pressing the "Retract probe" button</li> <li>▪ Error: immediately before probe retraction</li> </ul>
4	Warning buzzer 	Front of control cabinet	Warns about probe movement.  The buzzer buzzes in the following situations: <ul style="list-style-type: none"> <li>▪ Automatic mode: approx. 20 seconds before probe movement</li> <li>▪ Manual mode: immediately after pressing the "Retract probe" button</li> <li>▪ Error: immediately before probe retraction</li> </ul> The buzzer stops buzzing when the probe has reached its end position.

No.	Designation and photo	Location	Function
5	Shutter	on the duct opening of the rotary kiln	<ul style="list-style-type: none"> <li>▪ Protects from jet flames, hot material and gases from the duct opening.</li> <li>▪ Closes the kiln's duct opening when the probe is retracted.</li> <li>▪ A manual lock ensures that the duct opening is reliably closed when working near the duct opening.</li> </ul>
6	Protective installation with electric-lock access	around the retractor	<p>Prevents anyone from standing near the retractor when probe movement is possible.</p> <p>No probe movement is possible when the protective installation is open.</p> <p>When the protective installation is opened during operation:</p> <ul style="list-style-type: none"> <li>▪ the warning lamps flash</li> <li>▪ the warning buzzer buzzes</li> <li>▪ the probe moves out of the rotary kiln to parked position.</li> </ul>

**Additional warning horn**

A warning horn additionally installed by the operator has the same function as the enclosed warning buzzer described above. The additional warning horn must be installed if you cannot hear the warning buzzer properly due to ambient noise.

**Additional EMERGENCY-STOP switch**

An EMERGENCY-STOP switch additionally installed by the operator has the same function as the enclosed EMERGENCY-STOP switch described above. The additional EMERGENCY-STOP switch must be installed if the above-described EMERGENCY-STOP switch is difficult to access.

## Warning signs on the system

### Meaning of the warning signs

Warning signs on the gas sampling probe warn about danger areas. The warning signs must always be in place and easy to see.

### Illustration

The following illustration shows the location of the warning signs on the individual modules:

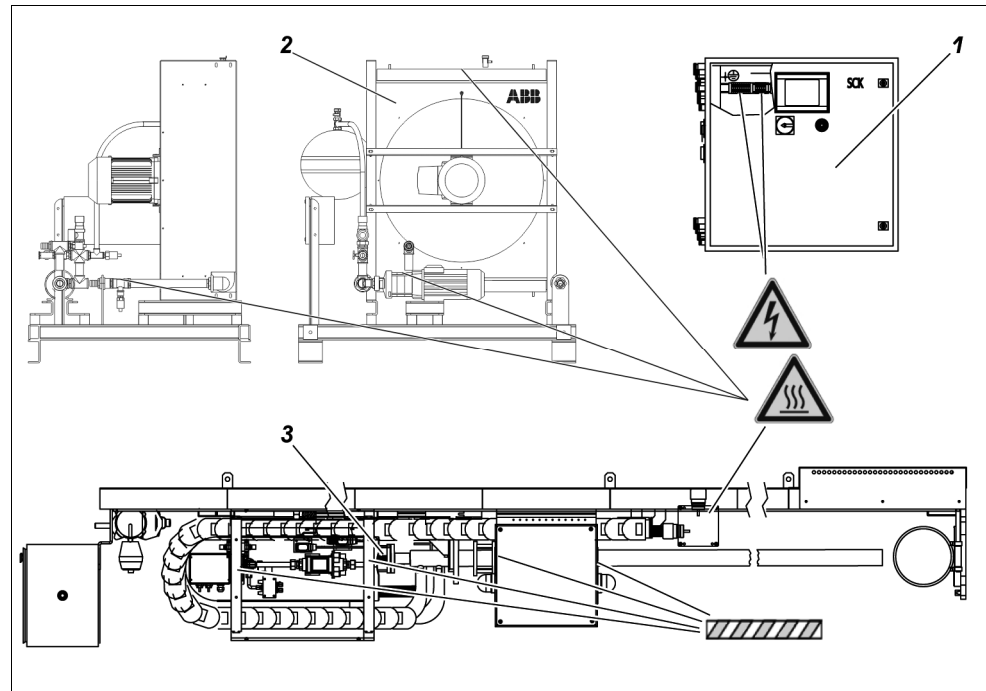

### Warning signs on the control cabinet

The warning signs on the control cabinet **(1)** have the following meaning:

Warning sign	Meaning
	Warns about current-carrying parts There is a risk of electrocution by current-carrying parts in the area of the terminal bar for normal mains supply and the terminal bar for the UPS. This also applies when the main switch is turned off.



### Warning signs on the cooling module

The warning signs on the cooling module **(2)** have the following meaning:

Warning sign	Meaning
	Warns about hot surfaces A risk of hot surfaces can be expected during operation. Particular danger areas are: all cooling water pipes and the cooling water pump and the surface of the heat exchanger.

**Warning signs on the retractor**

The warning signs on the retractor (3) have the following meaning:

Warning sign	Meaning
 A yellow triangular warning sign with a black border and three wavy lines representing heat.	<p>Warns about hot surfaces</p> <p>A risk of hot surfaces can be expected during operation. Particular danger areas are: all cooling water pipes, the heated sample gas line, the connection box for the heated sample gas line on the probe retractor, the heated sampling filter, the entire gas sampling probe, the metal structure of the probe retractor (particularly in the area of the mounting flange), the shutter on the duct opening.</p>
 A rectangular warning sign with a black border and diagonal yellow and black stripes.	<p>Warns about probe movements</p> <p>Retractor movement can be expected during operation. Do not stand in the area of travel of the probe or probe carriage until the probe is completely inserted or retracted and the warning lamps go out.</p>



## Requirements to be met by personnel, work places

### Personnel qualifications

Personnel handling the gas sampling system must meet the following requirements:

Personnel	Tasks	Required qualification
Transporter	Transport in the company Unpacking of the system	<ul style="list-style-type: none"> <li>▪ Trained crane operator/fork-lift driver</li> <li>▪ Experience with lifting apparatus</li> </ul>
Mechanical fitter	<ul style="list-style-type: none"> <li>▪ mechanical installation</li> <li>▪ mechanical disassembly</li> </ul>	<ul style="list-style-type: none"> <li>▪ Mechanical expert</li> </ul>
Electrical fitter	<ul style="list-style-type: none"> <li>▪ electrical installation</li> <li>▪ electrical disassembly</li> </ul>	<ul style="list-style-type: none"> <li>▪ Electrical expert</li> </ul>
Start-up personnel	<ul style="list-style-type: none"> <li>▪ Initial start-up</li> <li>▪ Putting back into operation</li> </ul>	<ul style="list-style-type: none"> <li>▪ Technician</li> <li>▪ familiar with the processes of cement production and specific works conditions</li> </ul>
Operator	Operation	<ul style="list-style-type: none"> <li>▪ Trained unskilled worker</li> </ul>
Mechanical maintenance personnel	on mechanical parts: <ul style="list-style-type: none"> <li>▪ Maintenance</li> <li>▪ Troubleshooting</li> <li>▪ Maintenance</li> <li>▪ Shutting down</li> </ul>	<ul style="list-style-type: none"> <li>▪ Mechanical expert</li> </ul>
Electrical maintenance personnel	on electric parts: <ul style="list-style-type: none"> <li>▪ Maintenance</li> <li>▪ Troubleshooting</li> <li>▪ Maintenance</li> <li>▪ Shutting down</li> </ul>	<ul style="list-style-type: none"> <li>▪ Electrical expert</li> <li>▪ Experience with controllers</li> </ul>
Storage personnel	<ul style="list-style-type: none"> <li>▪ correct storage</li> <li>▪ packing of the system for transport</li> </ul>	<ul style="list-style-type: none"> <li>▪ Trained unskilled worker</li> </ul>
Disposal personnel	Disposal of the gas sampling system	<ul style="list-style-type: none"> <li>▪ Trained disposal personnel</li> </ul>

## Work places

In order to ensure safe handling of the gas sampling system, personnel must work in certain work places designated for their activity.

The work places for the various activities are located in the following places:

<b>Activity</b>	<b>Work places</b>
Installation Start-up Maintenance Shutting down	at the various modules of the gas sampling system, depending on the task
Operation	depending on the particular task <ul style="list-style-type: none"><li>▪ at the control cabinet to operate the software</li><li>▪ around the gas sampling system to monitor operation, but NOT in the danger area around the retractor that is protected by the protective installation.</li></ul>

## Personal safety equipment

### General protective equipment

The following general protective equipment must be worn when performing any work in the area of the gas sampling system:

- Closed overalls with long trousers and long sleeves
- Safety shoes
- Safety gloves suitable for mechanical work
- Safety glasses
- Protective helmet
- If necessary, additional protective equipment if prescribed by the operator.

### Additional protective equipment

The following additional protective equipment is required when performing maintenance work:

- Dust mask
- Face mask against heat
- Heat-proof gloves and protective welder's clothing
- Respiratory protection against toxic gases from the rotary kiln

## Safety measures: Transport and unpacking

### Meaning

This section contains a summary of possible dangers during transport and unpacking of the gas sampling system and measures designed to prevent physical injuries.

### Dangers and preventive action

Observe the following dangers and take the specified preventive action when transporting and unpacking:

Danger	Where / in what situation does the danger arise?	Preventive action
Mechanical and material dangers due to moving or falling parts, anti-freeze, lubricating oil	During all work on the gas sampling system and in the vicinity of the gas sampling system	Wear general personal protective equipment: <ul style="list-style-type: none"> <li>▪ Closed overalls with long trousers and long sleeves</li> <li>▪ Safety shoes</li> <li>▪ Safety gloves suitable for mechanical work</li> <li>▪ Safety glasses</li> <li>▪ Protective helmet</li> <li>▪ If necessary, additional protective equipment if prescribed by the operator.</li> </ul>
Risk of crushing by heavy transport units	When lifting or lowering transport units	<ul style="list-style-type: none"> <li>▪ Only appropriately trained personnel may transport the transport units and only with the aid of the recommended transport equipment.</li> <li>▪ Do not stand under suspended loads.</li> <li>▪ Follow the transport instructions in these operating instructions carefully.</li> </ul>

## Safety measures: Installation

### Meaning

This section contains a summary of possible dangers during installation of the gas sampling system and measures designed to prevent physical injuries.

### Dangers and preventive action

Observe the following dangers and take the specified preventive action when installing the gas sampling system:

Danger	Where / in what situation does the danger arise?	Preventive action
Mechanical and material dangers due to moving or falling parts, anti-freeze, lubricating oil	During all work on the gas sampling system and in the vicinity of the gas sampling system	Wear general personal protective equipment: <ul style="list-style-type: none"> <li>▪ Closed overalls with long trousers and long sleeves</li> <li>▪ Safety shoes</li> <li>▪ Safety gloves suitable for mechanical work</li> <li>▪ Safety glasses</li> <li>▪ Protective helmet</li> <li>▪ If necessary, additional protective equipment if prescribed by the operator.</li> </ul>
Risk of crushing by heavy transport units	When lifting or lowering transport units	<ul style="list-style-type: none"> <li>▪ Only appropriately trained personnel may transport the transport units and only with the aid of the recommended transport equipment.</li> <li>▪ Do not stand under suspended loads.</li> <li>▪ Follow the transport instructions in these operating instructions carefully.</li> </ul>
Danger due to current-carrying parts	When working on electric components	<ul style="list-style-type: none"> <li>▪ Only specialized electrical personnel may work on the electric system.</li> <li>▪ Disconnect the gas sampling system from the power supply before opening the connection and terminal box.</li> <li>▪ Observe national regulations pertaining to electrical equipment.</li> </ul>

Danger	Where / in what situation does the danger arise?	Preventive action
Risk of burning due to hot surfaces, hot gases, jet flames	At the duct opening when installing the probe in the rotary kiln	<ul style="list-style-type: none"> <li>▪ Preferably install the probe when the rotary kiln is out of operation.</li> </ul> <p>If you install the probe when the rotary kiln is in operation:</p> <ul style="list-style-type: none"> <li>▪ Wear a face mask against heat, heat-proof gloves and protective welder's clothing and respiratory protection against toxic gases.</li> <li>▪ Keep the time in which the duct opening is open as short as possible.</li> </ul>
Danger due to harmful gases	Due to gases escaping from the duct opening of the rotary kiln	<ul style="list-style-type: none"> <li>▪ Only enter the danger area around the retractor when the shutter is closed.</li> <li>▪ Lock the shutter before commencing work.</li> <li>▪ Ensure adequate ventilation of the work place.</li> <li>▪ If work is unavoidable in the area of the duct opening, wear respiratory protection in addition to the general protective equipment.</li> </ul>
Danger due to harmful anti-freeze	In the cooling water of the cooling system	<ul style="list-style-type: none"> <li>▪ Avoid contact with the cooling water and the anti-freeze.</li> <li>▪ Wash any cooling water or anti-freeze off the skin immediately with water and soap.</li> <li>▪ If cooling water or anti-freeze gets in the eyes despite protective glasses, rinse them thoroughly under running water, holding the eyelids open.</li> <li>▪ Observe instructions in the anti-freeze manufacturer's safety data sheet.</li> </ul>

<b>Danger</b>	<b>Where / in what situation does the danger arise?</b>	<b>Preventive action</b>
Danger due to harmful lubricating oil	In the pneumatic box, on the pneumatic motor filter muffler, inside the pneumatic motor.	<ul style="list-style-type: none"> <li>▪ Avoid contact with lubricating oil.</li> <li>▪ Wash any lubricating oil off the skin immediately with water and soap.</li> <li>▪ If any lubricating oil gets in the eyes despite protective glasses, rinse them thoroughly under running water, holding the eyelids open.</li> <li>▪ Observe instructions in the lubricating oil manufacturer's safety data sheet.</li> </ul>

## Safety measures: Start-up

### Meaning

This section contains a summary of possible dangers during start-up of the gas sampling system and measures designed to prevent physical injuries.

### Dangers and preventive action

Observe the following dangers and take the specified preventive action when starting-up the gas sampling system:

Danger	Where / in what situation does the danger arise?	Preventive action
Mechanical, thermal and material dangers due to moving or falling parts, hot surfaces, hot cooling water, anti-freeze, compressed air, lubricating oil	During all work on the gas sampling system and in the vicinity of the gas sampling system	Wear general personal protective equipment: <ul style="list-style-type: none"> <li>▪ Closed overalls with long trousers and long sleeves</li> <li>▪ Safety shoes</li> <li>▪ Safety gloves suitable for mechanical work</li> <li>▪ Safety glasses</li> <li>▪ Protective helmet</li> <li>▪ If necessary, additional protective equipment if prescribed by the operator.</li> </ul>
Risk of crushing due to moving gas sampling probe	In the travel area of the retractor when the probe moves in or out. This is the case in the following situations: <ul style="list-style-type: none"> <li>▪ at unforeseeable times during automatic mode</li> <li>▪ in the event of the following errors in automatic mode:               <ul style="list-style-type: none"> <li>▪ failure or interruption of the power supply</li> <li>▪ failure of the compressed-air supply</li> <li>▪ failure of the control system</li> </ul> </li> <li>▪ when manually starting probe travel</li> <li>▪ when actuating the service switch</li> <li>▪ when opening the protective installation securing the danger area around the retractor</li> </ul>	<ul style="list-style-type: none"> <li>▪ Do not enter the danger area around the probe retractor until it is at standstill and the warning lamps and buzzer are off.</li> <li>▪ Never stand in the danger area around the probe retractor when the protective installation is closed.</li> <li>▪ When the warning lamps light up or the warning buzzer buzzes, leave the danger area around the probe retractor immediately as the probe is about to move at any moment.</li> <li>▪ Press the EMERGENCY STOP switch immediately if anyone is still in the danger area around the retractor after the warning lamps light up or the warning buzzer buzzes.</li> </ul>



<b>Danger</b>	<b>Where / in what situation does the danger arise?</b>	<b>Preventive action</b>
Danger due to current-carrying parts	When working on electric components	<ul style="list-style-type: none"> <li>▪ Only specialized electrical personnel may work on the electric system.</li> <li>▪ Disconnect the gas sampling system from the power supply before opening the connection and terminal box.</li> <li>▪ Observe national regulations pertaining to electrical equipment.</li> </ul>
Risk of burning due to hot surfaces	<p>The following components are very hot during and after operation of the gas sampling system:</p> <ul style="list-style-type: none"> <li>▪ the cooling module</li> <li>▪ the heated sample gas lines</li> <li>▪ the connection box for the heated sample gas line on the retractor</li> <li>▪ the heated sampling filter</li> <li>▪ the entire gas sampling probe</li> <li>▪ the metal structure of the retractor</li> <li>▪ the shutter of the duct opening</li> </ul>	<ul style="list-style-type: none"> <li>▪ Do not touch these components during and after operation.</li> <li>▪ Do not touch these components until they have cooled down to less than 50 °C.</li> <li>▪ If it is unavoidable to touch hot components, wear a face mask against heat, heat-proof gloves and protective welder's clothing.</li> </ul>
Risk of burning due to falling or spalling material.	After the probe moves out of the rotary kiln, hot material may fall or spall off the probe.	<ul style="list-style-type: none"> <li>▪ Never enter the danger area around the retractor during operation.</li> <li>▪ Do not approach the retracted probe until it has cooled down.</li> <li>▪ If it is unavoidable to approach the hot probe, wear a face mask against heat, heat-proof gloves and protective welder's clothing.</li> </ul>

Danger	Where / in what situation does the danger arise?	Preventive action
Danger due to harmful gases, jet flames	Due to gases escaping from the duct opening of the rotary kiln	<ul style="list-style-type: none"> <li>▪ Only enter the danger area around the retractor when the shutter is closed.</li> <li>▪ Lock the shutter before commencing work.</li> <li>▪ Ensure adequate ventilation of the work place.</li> <li>▪ If work is unavoidable in the area of the duct opening, wear respiratory protection in addition to the general protective equipment.</li> </ul>
Risk of scalding due to hot cooling water	When working on the cooling water system, particularly: <ul style="list-style-type: none"> <li>▪ ventilation openings</li> <li>▪ Screw connections</li> </ul>	<ul style="list-style-type: none"> <li>▪ Do not perform work on the cooling water system until it has cooled down.</li> </ul>
Danger due to harmful anti-freeze	In the cooling water of the cooling system	<ul style="list-style-type: none"> <li>▪ Avoid contact with the cooling water and the anti-freeze.</li> <li>▪ Wash any cooling water or anti-freeze off the skin immediately with water and soap.</li> <li>▪ If cooling water or anti-freeze gets in the eyes despite protective glasses, rinse them thoroughly under running water, holding the eyelids open.</li> <li>▪ Observe instructions in the anti-freeze manufacturer's safety data sheet.</li> </ul>
Danger due to harmful lubricating oil	In the pneumatic box, on the pneumatic motor filter muffler, inside the pneumatic motor.	<ul style="list-style-type: none"> <li>▪ Avoid contact with lubricating oil.</li> <li>▪ Wash any lubricating oil off the skin immediately with water and soap.</li> <li>▪ If any lubricating oil gets in the eyes despite protective glasses, rinse them thoroughly under running water, holding the eyelids open.</li> <li>▪ Observe instructions in the lubricating oil manufacturer's safety data sheet.</li> </ul>
Risk of slipping	Around the gas sampling system due to cooling water or lubricating oil that escapes or is spilled.	<ul style="list-style-type: none"> <li>▪ Always keep the floor around the gas sampling system clean and dry.</li> </ul>

## Safety measures: Operation

### Meaning

This section contains a summary of possible dangers during operation of the gas sampling system and measures designed to prevent physical injuries.

### Dangers and preventive action

Observe the following dangers and take the specified preventive action when operating the gas sampling system:

Danger	Where / in what situation does the danger arise?	Preventive action
Mechanical, thermal and material dangers due to moving or falling parts, hot surfaces, hot cooling water, anti-freeze, compressed air, lubricating oil	During all work on the gas sampling system and in the vicinity of the gas sampling system	Wear general personal protective equipment: <ul style="list-style-type: none"> <li>▪ Closed overalls with long trousers and long sleeves</li> <li>▪ Safety shoes</li> <li>▪ Safety gloves suitable for mechanical work</li> <li>▪ Safety glasses</li> <li>▪ Protective helmet</li> <li>▪ If necessary, additional protective equipment if prescribed by the operator.</li> </ul>
Risk of crushing due to moving gas sampling probe	In the travel area of the retractor when the probe moves in or out. This is the case in the following situations: <ul style="list-style-type: none"> <li>▪ at unforeseeable times during automatic mode</li> <li>▪ in the event of the following errors in automatic mode:               <ul style="list-style-type: none"> <li>▪ failure or interruption of the power supply</li> <li>▪ failure of the compressed-air supply</li> <li>▪ failure of the control system</li> </ul> </li> <li>▪ when manually starting probe travel</li> <li>▪ when actuating the service switch</li> <li>▪ when opening the protective installation securing the danger area around the retractor</li> </ul>	<ul style="list-style-type: none"> <li>▪ Never enter the danger area around the retractor during operation.</li> <li>▪ Press the EMERGENCY-STOP switch immediately if anyone is in the danger area around the retractor after the warning lamps light up or the warning buzzer buzzes.</li> </ul>

Danger	Where / in what situation does the danger arise?	Preventive action
Danger due to current-carrying parts	Electric components in general, above all damaged electric components	<ul style="list-style-type: none"> <li>▪ If you are not specialized electrical personnel: <ul style="list-style-type: none"> <li>▪ Never open electric components.</li> <li>▪ Never touch damaged electric components, cables or the inside of electric components.</li> </ul> </li> <li>▪ Only specialized electrical personnel may work on the electrical system.</li> </ul>
Risk of burning due to hot surfaces	<p>The following components are very hot during and after operation of the gas sampling system:</p> <ul style="list-style-type: none"> <li>▪ the cooling module</li> <li>▪ the heated sample gas lines</li> <li>▪ the connection box for the heated sample gas line on the retractor</li> <li>▪ the heated sampling filter</li> <li>▪ the entire gas sampling probe</li> <li>▪ the metal structure of the retractor</li> <li>▪ the shutter of the duct opening</li> </ul>	<ul style="list-style-type: none"> <li>▪ Never enter the danger area around the retractor during operation.</li> <li>▪ Do not touch these components during and after operation.</li> <li>▪ If it is unavoidable to touch hot components, wear a face mask against heat, heat-proof gloves and protective welder's clothing.</li> </ul>
Risk of burning due to falling or spalling material.	After the probe moves out of the rotary kiln, hot material may fall or spall off the probe.	<ul style="list-style-type: none"> <li>▪ Never enter the danger area around the retractor during operation.</li> <li>▪ Do not approach the retracted probe until it has cooled down.</li> <li>▪ If it is unavoidable to approach the hot probe, wear a face mask against heat, heat-proof gloves and protective welder's clothing.</li> </ul>
Danger due to harmful gases, jet flames	If gases escape from the duct opening on the rotary kiln when the shutter is open during operation.	<ul style="list-style-type: none"> <li>▪ Never enter the danger area around the retractor during operation.</li> <li>▪ Ensure adequate ventilation of the work place.</li> </ul>
Risk due to hot cooling water	In the event of hot cooling water escaping if an error occurs	<ul style="list-style-type: none"> <li>▪ Wait until the entire cooling water has been evacuated before approaching.</li> </ul>

<b>Danger</b>	<b>Where / in what situation does the danger arise?</b>	<b>Preventive action</b>
Danger due to harmful anti-freeze	Cooling water escaping from the cooling system in the event of an error	<ul style="list-style-type: none"> <li>▪ Avoid contact with the cooling water and the anti-freeze.</li> <li>▪ Wash any cooling water or anti-freeze off the skin immediately with water and soap.</li> <li>▪ If cooling water or anti-freeze gets in the eyes despite protective glasses, rinse them thoroughly under running water, holding the eyelids open.</li> <li>▪ Observe instructions in the anti-freeze manufacturer's safety data sheet.</li> </ul>
Danger due to harmful lubricating oil	Lubricating oil escaping from the pneumatic module in the event of an error	<ul style="list-style-type: none"> <li>▪ Avoid contact with lubricating oil.</li> <li>▪ Wash any lubricating oil off the skin immediately with water and soap.</li> <li>▪ If any lubricating oil gets in the eyes despite protective glasses, rinse them thoroughly under running water, holding the eyelids open.</li> <li>▪ Observe instructions in the lubricating oil manufacturer's safety data sheet.</li> </ul>
Risk of slipping	Around the gas sampling system due to cooling water or lubricating oil that escapes or is spilled.	<ul style="list-style-type: none"> <li>▪ Always keep the floor around the gas sampling system clean and dry.</li> </ul>

## Safety measures: Maintenance and troubleshooting

### Meaning

This section contains a summary of possible dangers during maintenance and troubleshooting of the gas sampling system and measures designed to prevent physical injuries.

### Dangers and preventive action

Observe the following dangers and take the specified preventive action when maintaining and troubleshooting the gas sampling system:

Danger	Where / in what situation does the danger arise?	Preventive action
Mechanical, thermal and material dangers due to moving or falling parts, hot surfaces, hot cooling water, anti-freeze, compressed air, lubricating oil	During all work on the gas sampling system and in the vicinity of the gas sampling system	Wear general personal protective equipment: <ul style="list-style-type: none"> <li>▪ Closed overalls with long trousers and long sleeves</li> <li>▪ Safety shoes</li> <li>▪ Safety gloves suitable for mechanical work</li> <li>▪ Safety glasses</li> <li>▪ Protective helmet</li> <li>▪ If necessary, additional protective equipment if prescribed by the operator.</li> </ul>
Risk of crushing by heavy transport units	When lifting or lowering transport units	<ul style="list-style-type: none"> <li>▪ Only appropriately trained personnel may transport the transport units and only with the aid of the recommended transport equipment.</li> <li>▪ Do not stand under suspended loads.</li> <li>▪ Follow the transport instructions in these operating instructions carefully.</li> </ul>

<b>Danger</b>	<b>Where / in what situation does the danger arise?</b>	<b>Preventive action</b>
Risk of crushing due to moving gas sampling probe	<p>In the travel area of the retractor when the probe moves in or out. This is the case in the following situations:</p> <ul style="list-style-type: none"> <li>▪ at unforeseeable times during automatic mode</li> <li>▪ in the event of the following errors in automatic mode: <ul style="list-style-type: none"> <li>▪ failure or interruption of the power supply</li> <li>▪ failure of the compressed-air supply</li> <li>▪ failure of the control system</li> </ul> </li> <li>▪ when manually starting probe travel</li> <li>▪ when actuating the service switch</li> <li>▪ when opening the protective installation securing the danger area around the retractor</li> </ul>	<ul style="list-style-type: none"> <li>▪ Press the service switch before performing any work on the gas sampling system.</li> <li>▪ Additionally press the EMERGENCY-STOP switch before working on the retractor.</li> <li>▪ Do not enter the danger area around the retractor until it is at standstill and the warning lamps and buzzer are off.</li> <li>▪ Never stand in the danger area around the retractor when the protective installation is closed.</li> <li>▪ When the warning lamps light up or the warning buzzer buzzes, leave the danger area around the probe retractor immediately as the probe is about to move at any moment.</li> <li>▪ Press the EMERGENCY-STOP switch immediately if anyone is still in the danger area around the retractor after the warning lamps light up or the warning buzzer buzzes.</li> </ul>
Danger due to current-carrying parts	When working on electric components	<ul style="list-style-type: none"> <li>▪ Only specialized electrical personnel may work on the electrical system.</li> <li>▪ Disconnect the gas sampling system from the power supply before working on other electric components.</li> <li>▪ Observe national regulations pertaining to electrical equipment.</li> </ul>

Danger	Where / in what situation does the danger arise?	Preventive action
Risk of burning due to hot surfaces	<p>The gas sampling system is very hot during and after operation of the gas sampling system, particularly:</p> <ul style="list-style-type: none"> <li>▪ the cooling module</li> <li>▪ the heated sample gas lines</li> <li>▪ the connection box for the heated sample gas line on the retractor</li> <li>▪ the heated sampling filter</li> <li>▪ the entire gas sampling probe</li> <li>▪ the metal structure of the retractor</li> <li>▪ the shutter of the duct opening</li> </ul>	<ul style="list-style-type: none"> <li>▪ Do not touch the gas sampling system during and after operation.</li> <li>▪ Do not touch the gas sampling system until it has cooled down to less than 50 °C.</li> <li>▪ If it is unavoidable to touch during operation, wear a face mask against heat, heat-proof gloves and protective welder's clothing.</li> </ul>
Risk of burning due to falling or spalling material.	After the probe moves out of the rotary kiln, hot material may fall or spill off the probe.	<ul style="list-style-type: none"> <li>▪ Never enter the danger area around the retractor during operation.</li> <li>▪ Do not approach the retracted probe until it has cooled down.</li> <li>▪ If it is unavoidable to approach the hot probe, wear a face mask against heat, heat-proof gloves and protective welder's clothing.</li> </ul>
Risk of burning due to hot surfaces, hot gases, jet flames	At the duct opening when inspecting and cleaning the wall tube	<ul style="list-style-type: none"> <li>▪ Preferably inspect the wall tube when the rotary kiln is out of operation.</li> </ul> <p>If you check or clean the wall tube when the rotary kiln is in operation:</p> <ul style="list-style-type: none"> <li>▪ Wear a face mask against heat, heat-proof gloves and protective welder's clothing and respiratory protection against toxic gases.</li> <li>▪ Keep the time in which the duct opening is open as short as possible.</li> </ul>



<b>Danger</b>	<b>Where / in what situation does the danger arise?</b>	<b>Preventive action</b>
Danger due to harmful gases, jet flames	Due to gases escaping from the duct opening of the rotary kiln	<ul style="list-style-type: none"> <li>▪ Ensure adequate ventilation of the work place.</li> <li>▪ Only enter the danger area around the retractor when the shutter is closed.</li> <li>▪ Lock the shutter before commencing work, if this is indicated.</li> <li>▪ If work is unavoidable in the area of the duct opening, wear respiratory protection.</li> </ul>
Risk of scalding due to hot cooling water	When working on the cooling water system, particularly: <ul style="list-style-type: none"> <li>▪ ventilation openings</li> <li>▪ screw connections</li> </ul>	<ul style="list-style-type: none"> <li>▪ Do not perform work on the cooling water circuit until the gas sampling system has cooled down.</li> </ul>
Danger due to harmful anti-freeze	In the cooling water of the cooling system	<ul style="list-style-type: none"> <li>▪ Avoid contact with the cooling water and the anti-freeze.</li> <li>▪ Wash any cooling water and anti-freeze off the skin immediately with water and soap.</li> <li>▪ If cooling water or anti-freeze gets in the eyes despite protective glasses, rinse them thoroughly under running water, holding the eyelids open.</li> <li>▪ Observe instructions in the anti-freeze manufacturer's safety data sheet.</li> </ul>
Danger due to harmful lubricating oil	In the pneumatic box, on the pneumatic motor filter muffler, inside the pneumatic motor.	<ul style="list-style-type: none"> <li>▪ Avoid contact with lubricating oil.</li> <li>▪ Wash any lubricating oil off the skin immediately with water and soap.</li> <li>▪ If any lubricating oil gets in the eyes despite protective glasses, rinse them thoroughly under running water, holding the eyelids open.</li> <li>▪ Observe instructions in the lubricating oil manufacturer's safety data sheet.</li> </ul>
Danger due to harmful dust	While cleaning the gas sampling system	<ul style="list-style-type: none"> <li>▪ Wear a dust mask.</li> <li>▪ Wash any dust off the skin immediately with water and soap.</li> </ul>

<b>Danger</b>	<b>Where / in what situation does the danger arise?</b>	<b>Preventive action</b>
Risk of slipping	Around the gas sampling system due to cooling water or lubricating oil that escapes or is spilled.	<ul style="list-style-type: none"> <li>▪ Always keep the floor around the gas sampling system clean and dry.</li> </ul>

Topic	Page
General transport information.....	84
Transport the system in the company .....	87
Unpacking the system .....	89
Scope of delivery .....	90

## General transport information

### Heavy transport units



#### **Danger of crushing when lifting or lowering the transport unit**

- ▶ Only appropriately trained personnel may transport the transport units and only with the aid of the recommended transport equipment.
- ▶ Do not stand under suspended loads.
- ▶ Follow the transport instructions in these operating instructions carefully.

### Mechanical and material dangers



#### **Risk of injury in the area of the gas sampling system due to moving or falling parts, anti-freeze, lubricating oil**

Wear general personal protective equipment:

- ▶ Closed overalls with long trousers and long sleeves
- ▶ Safety shoes
- ▶ Safety gloves suitable for mechanical work
- ▶ Safety glasses
- ▶ Protective helmet
- ▶ If necessary, additional protective equipment if prescribed by the operator.

### General remarks regarding transport

During transport make sure that the transport packaging is not damaged or removed. Observe the below-mentioned temperature and humidity limits during transport.

In the event of transport damage attributable to improper handling, instigate damage assessment by the carrier (rail, post office, and forwarder) within seven days.

Make sure that none of the enclosed accessories are lost during unpacking. Store the screws in case the unit needs to be transported again in the future.

### Transport with crane

The retractor including the probe weighs 450–500 kg depending on the length of the retractor and type of probe. A crane and suitable transport equipment is required for transport and unpacking. Use the transport lugs to fasten the lifting ropes. The lifting ropes must be long enough to ensure an angle of at least 60° under strain. Otherwise the retractor cabinet can get twisted.

If the cooling module is also transported by crane, observe the same points.

## Transporting the modules

Observe the following instructions with regard to transporting the modules:

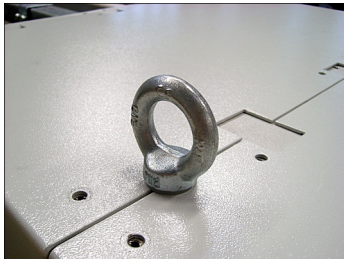
Module	Weight	Transport conditions
Retractor including probe	max. 500 kg	<ul style="list-style-type: none"> <li>▪ The retractor is delivered with two transport supports (see illustration in <i>Probe retractor</i> on page 26). They are removed during assembly.</li> <li>▪ During storage, support the tip of the assembled gas sampling probe.</li> <li>▪ Only store after draining all water.</li> <li>▪ Lifting gear may only be attached at the designated attachment points (transport lugs).</li> </ul>  <ul style="list-style-type: none"> <li>▪ Transport recommendation: Crane</li> </ul> <p><b>Note:</b> The unpacked retractor must not be transported using a fork-lift truck.</p>
Cooling module	250 kg	<ul style="list-style-type: none"> <li>▪ Only store after draining all water.</li> <li>▪ Lifting gear may only be attached at the designated attachment points (transport lugs).</li> <li>▪ Transport recommendation: For-lift truck or crane</li> </ul>
Control cabinet	75 kg	<ul style="list-style-type: none"> <li>▪ Lay the control cabinet on its back for transport.</li> <li>▪ Use a suitable transport pallet for transport.</li> <li>▪ Transport recommendation: For-lift truck or hand lift</li> </ul>
Transformer (optional)	140 kg	<ul style="list-style-type: none"> <li>▪ Use a suitable transport pallet for transport (transport recommendation: fork-lift truck or hand lift).</li> <li>▪ The casing is also fitted with transport lugs and can be lifted using a crane.</li> </ul>
Compressed-air tank (optional)	90 kg	<ul style="list-style-type: none"> <li>▪ May only be transported on its side.</li> <li>▪ Ensure adequate protection of the attachments.</li> <li>▪ Only store after draining all water.</li> <li>▪ Transport recommendation: For-lift truck or hand lift</li> </ul>

## Environmental conditions

Observe the following physical limits when transporting the modules:

Module	Environmental conditions for transport
Retractor including probe	<p><b>Ambient temperature:</b> +5 °C to +55 °C, after completely draining all water and drying parts in contact with cooling water or condensation: -20 °C to +55 °C</p> <p><b>Air humidity:</b> Year-round average max. 75 %, short-term max. 95 %, occasional slight condensation is permitted</p>
Cooling module	<p><b>Ambient temperature:</b> +5 °C to +55 °C, after completely draining all water and drying parts in contact with cooling water or condensation: -20 °C to +55 °C</p> <p><b>Air humidity:</b> Year-round average max. 75 %, short-term max. 95 %, occasional slight condensation is permitted</p>

<b>Module</b>	<b>Environmental conditions for transport</b>
Control cabinet	<b>Ambient temperature:</b> -20 °C to +55 °C <b>Air humidity:</b> Year-round average max. 75 %, short-term max. 95 %, occasional slight condensation is permitted
Transformer (optional)	<b>Ambient temperature:</b> -25 °C to +55 °C <b>Air humidity:</b> Year-round average max. 80 %, short-term max. 95 %, without condensation
Compressed-air tank (optional)	<b>Ambient temperature:</b> +5 °C to +55 °C, after completely draining all water and drying parts in contact with cooling water or condensation: -20 °C to +55 °C <b>Air humidity:</b> Year-round average max. 75 %, short-term max. 95 %, occasional slight condensation is permitted

## Transport the system in the company

### Mechanical and material dangers

#### **▲WARNING**

**Risk of injury in the area of the gas sampling system due to moving or falling parts, anti-freeze, lubricating oil**

Wear general personal protective equipment:

- ▶ Closed overalls with long trousers and long sleeves
- ▶ Safety shoes
- ▶ Safety gloves suitable for mechanical work
- ▶ Safety glasses
- ▶ Protective helmet
- ▶ If necessary, additional protective equipment if prescribed by the operator.

### Heavy transport units

#### **▲WARNING**

**Danger of crushing when lifting or lowering the transport unit**

- ▶ Only appropriately trained personnel may transport the transport units and only with the aid of the recommended transport equipment.
- ▶ Do not stand under suspended loads.
- ▶ Follow the transport instructions in these operating instructions carefully.

### Transporting the modules

Observe the following instructions with regard to transport in the company:

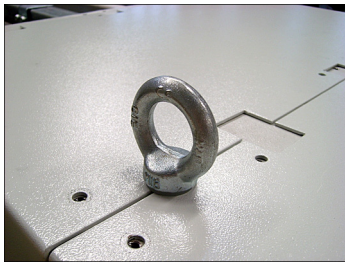
Module	Weight	Transport conditions
Retractor including probe	max. 500 kg	<ul style="list-style-type: none"> <li>▪ Probe tip must be adequately fixed to the retractor (e.g. with a load strap) in order to avoid bouncing, that may damage the rollers and rails.</li> <li>▪ Use the two enclosed transport supports for transport in the company (see illustration in <i>Probe retractor</i> on page 26).</li> <li>▪ Lifting gear may only be attached at the designated attachment points (transport lugs).</li> </ul>  <ul style="list-style-type: none"> <li>▪ Transport recommendation: Crane</li> </ul> <p><b>Note:</b> Do not transport using a fork-lift truck.</p>
Cooling module	250 kg	<ul style="list-style-type: none"> <li>▪ Protect cooling fins with a board to avoid damage.</li> <li>▪ Only store after draining all water.</li> <li>▪ Lifting gear may only be attached at the designated attachment points (transport lugs).</li> <li>▪ Transport recommendation: For-lift truck or crane</li> </ul>
Control cabinet	75 kg	<ul style="list-style-type: none"> <li>▪ Mark connecting cables so that you know where to install what.</li> <li>▪ Lay the control cabinet on its back for transport.</li> <li>▪ Use a suitable transport pallet for transport.</li> <li>▪ Transport recommendation: For-lift truck or hand lift</li> </ul>

<b>Module</b>	<b>Weight</b>	<b>Transport conditions</b>
Compressed-air tank	90 kg	<ul style="list-style-type: none"> <li>▪ Disassemble the compressed-air system for transport.</li> <li>▪ The compressed-air tank may only be transported on its side.</li> <li>▪ Ensure adequate protection of the attachments.</li> <li>▪ Transport recommendation: For-lift truck or hand lift</li> </ul>
Transformer	140 kg	<ul style="list-style-type: none"> <li>▪ Use a suitable transport pallet for transport.</li> <li>▪ Lifting gear may only be attached at the designated attachment points (transport lugs).</li> <li>▪ Transport recommendation: For-lift truck, hand lift or crane</li> </ul>



# Unpacking the system

## Mechanical and material dangers

### **WARNING**

#### **Risk of injury in the area of the gas sampling system due to moving or falling parts, anti-freeze, lubricating oil**

Wear general personal protective equipment:

- ▶ Closed overalls with long trousers and long sleeves
- ▶ Safety shoes
- ▶ Safety gloves suitable for mechanical work
- ▶ Safety glasses
- ▶ Protective helmet
- ▶ If necessary, additional protective equipment if prescribed by the operator.

## Heavy transport units

### **WARNING**

#### **Danger of crushing when lifting or lowering the transport unit**

- ▶ Only appropriately trained personnel may transport the transport units and only with the aid of the recommended transport equipment.
- ▶ Do not stand under suspended loads.
- ▶ Follow the transport instructions in these operating instructions carefully.

## Instructions

Perform the following steps to unpack the system:

Step	Procedure
1	Remove outer packaging: <ul style="list-style-type: none"><li>▪ Transport crate</li><li>▪ Tensioning straps</li><li>▪ Cardboard, films and wooden parts</li></ul>
2	Undo fasteners holding the system parts on the pallet.
3	Lift system parts off the pallet with a crane, fork-lift truck or hand lift (observe transport recommendations in <i>Transporting the system in the company</i> on page 87). <b>Note:</b> The retractor must not be transported with a fork-lift truck.
4	Dispose of packaging material in accordance with the national regulations.
5	Transport system parts to the place of installation (see <i>Transporting the system in the company</i> on page 87).

## Scope of delivery

### Scope of delivery

The following components are delivered as standard:

- Probe retractor including gas sampling probe (H or 60S)
- Control cabinet
- Cooling module
- Cooling water hose (30 m)
- Bottle of compressed-air lubricant (1 l)
- Complete documentation DE/EN on CD-ROM
- System manual

### Optional

The following optional components may be included in the scope of delivery:

- 250-l compressed-air tank
- Compressed-air piping (25 m)
- Transformer IP44

<b>Topic</b>	<b>Page</b>
Overview: installation.....	92
Checking site conditions.....	93
Installing the probe retractor.....	95
Installing the control cabinet.....	98
Installing the compressed-air supply.....	99
Installing the cooling module.....	101
Installing the cooling water circuit.....	103
Connecting the sample gas line to the retractor.....	104
Connecting internal electric cables.....	105
Connecting external electric cables.....	107

## Overview: installation

### Introduction

This section contains a list of tasks to be performed when installing the gas sampling system. Links are given to the specific installation instructions describing installation of the various modules in detail.



It is recommended to have initial startup of the gas sampling system performed by the manufacturer's trained personnel or by the supplier.

### Preparations for installations and installation

In order to be able to install the various modules of the gas sampling system, preparations must be made at the cement works. A list of preparatory tasks is given in the "Engineering Guideline".

The rotary kiln must be shut down during installation of the wall tube. Installation of the gas sampling system should also preferably be performed while the kiln is shut down. If installation is performed while the kiln is operating, personnel must always wear adequate heat-proof clothing during assembly of the probe retractor (uncovered duct opening!).

### Instructions

Proceed as follows to install the complete system:

Step	Procedure	Instructions in ...
1	Check place of installation of the various modules of the gas sampling system.	<i>Checking site conditions on page 93</i>
2	Install the probe retractor such that personnel are not endangered and the system cannot be damaged.	<i>Installing the probe retractor on page 95</i>
3	Install control cabinet in suitable place.	<i>Installing the control cabinet on page 98</i>
4	Install compressed-air supply, install compressed-air tank if necessary.	<i>Installing the compressed-air supply on page 99</i>
5	Install cooling module.	<i>Installing the cooling module on page 101</i>
6	Lay and connect cooling water hoses.	<i>Installing the cooling water circuit on page 103</i>
7	Connect external sample gas line to retractor.	<i>Connecting the sample gas line to the retractor on page 104</i>
8	Connect electric lines.	<i>Connecting internal electric cables on page 105</i>
9	Connect external electric cables.	<i>Connecting external electric cables on page 107</i>

## Checking site conditions

Mechanical, thermal and material dangers



**Risk of injury in the area of the gas sampling system due to moving or falling parts, hot surfaces, anti-freeze, compressed air, lubricating oil**

Wear general personal protective equipment:

- ▶ Closed overalls with long trousers and long sleeves
- ▶ Safety shoes
- ▶ Safety gloves suitable for mechanical work
- ▶ Safety glasses
- ▶ Protective helmet
- ▶ If necessary, additional protective equipment if prescribed by the operator.

**Meaning**

The purpose of this task is to check whether the gas sampling system site is correctly prepared.

**Instructions**

How to check site conditions:

Step	Procedure
1	Using the checklist, check whether the site conditions for the various modules of the gas sampling system are fulfilled and that preparations for installation have been completed.
2	Only continue with installation of the gas sampling system once all conditions have been met.

**Site conditions checklist**

The following conditions must be met:

Conditions	Description in the "Engineering Guideline" in ...	OK
General rules regarding choice of installation site were observed, environmental conditions taken into account.	<i>General rules regarding choosing the place of installation of the peripheral modules</i> <i>Environmental condition requirements</i>	
Installation position of probe and probe retractor defined.	<i>Positioning the gas sampling probe</i>	
There is a suitable position to install the control cabinet with an unobstructed view of the probe retractor.	<i>Choosing the place of installation of the control cabinet</i>	
Position to set up the cooling module defined.	<i>Choosing the place of installation of the cooling module</i>	
If a compressed-air tank is required: Position to set up the compressed-air tank defined.	<i>Choosing the place of installation of the compressed-air tank</i>	
A suspension device for the probe retractor has been prepared and holes drilled for installation of the other modules.	<i>Fastening elements and attachment points</i>	

Conditions	Description in the "Engineering Guideline" in ...	OK
Wall tube and mounting flange manufactured and installed.	<i>Creating the wall tube with mounting flange</i> <i>Installing the wall tube</i>	
The power and compressed-air supply conforms to the requirements of the gas sampling system.	<i>Power and compressed-air supply requirements</i>	
Air cannon, if present, is integrated into the gas sampling system control system only.	<i>Integrating the air cannon into the control system</i>	
The danger area around the probe retractor is protected by a protective installation.	<i>Creating the base area for the retractor</i> <i>Creating the protective installation around the retractor</i>	

## Installing the probe retractor

Mechanical, thermal and material dangers



**Risk of injury in the area of the gas sampling system due to moving or falling parts, hot surfaces, anti-freeze, compressed air, lubricating oil**

Wear general personal protective equipment:

- ▶ Closed overalls with long trousers and long sleeves
- ▶ Safety shoes
- ▶ Safety gloves suitable for mechanical work
- ▶ Safety glasses
- ▶ Protective helmet
- ▶ If necessary, additional protective equipment if prescribed by the operator.

Heavy transport units



**Danger of crushing when lifting or lowering the transport unit**

- ▶ Only appropriately trained personnel may transport the transport units and only with the aid of the recommended transport equipment.
- ▶ Do not stand under suspended loads.
- ▶ Follow the transport instructions in these operating instructions carefully.

Hot surfaces, hot gases, jet flames



**Risk of burning due to jet flames and hot gases at the uncovered duct opening when the rotary kiln is in operation.**

- ▶ Preferably install or remove the probe when the rotary kiln is out of operation.
- ▶ If you install or remove the probe when the rotary kiln is in operation:
  - Wear a face mask against heat, heat-proof gloves and protective welder's clothing and respiratory protection against toxic gases.
  - Keep the time in which the duct opening is open as short as possible.

Screws required for assembly

- 6 suspension bolts, diameter 16 mm, material round steel S235JR (St37)

Requirements

The following requirements must be met in order to install the probe retractor:

- The site conforms to the designated site conditions (criteria see *Choosing the place of installation of the peripheral modules*).
- 6 fastening points are present to affix the probe retractor.
- The probe retractor is unpacked.

Instructions:  
Installing the probe retractor

How to install the probe retractor:

Step	Procedure
1	Set up probe retractor at the place of installation.

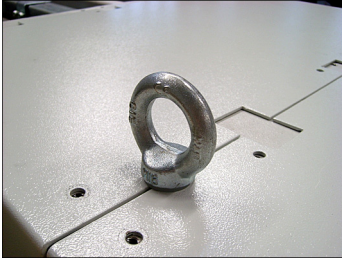
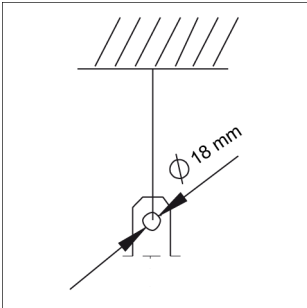
Step	Procedure
2	Suspend probe retractor on transport lugs (see photo) using suitable lifting gear.  <b>Note:</b> Pay particular attention to suitable fastening points of the lifting equipment. Observe relevant local regulations.
3	Lift probe retractor so far that you can remove the two mounted transport supports. <b>Note:</b> Store the transport supports for any future transport.
4	Position probe retractor in the designated position and install appropriate support.
5	Connect the fastening elements of the probe retractor and the system. There are 6 fastening straps on the probe retractor for this purpose (see Figure). Maximum load per suspension point is 10,000 N; ensure even loading of the fastening elements.  <b>CAUTION!</b> The screw-in transport lugs are for transporting the probe retractor only but not for permanent suspension. <b>For permanent suspension of the probe retractor, only use the 6 designated fastening straps.</b>
6	Remove dummy flange on wall tube. <b>WARNING!</b> Risk of burning due to jet flames and hot gases at the uncovered duct opening when the rotary kiln is in operation. <b>Wear a face mask against heat, heat-proof gloves and protective welder's clothing and respiratory protection against toxic gases.</b>
7	Flange the mounting flange of the probe retractor on the kiln wall tube.
8	Remove lifting gear and support material.
9	Check whether probe retractor is fastened stably enough and adjusted to local conditions.

### Moving the probe during assembly

During assembly it may be necessary to move the probe retractor without with compressed-air supply or control cabinet. However, this should be limited to absolutely necessary cases. Proceed as follows:

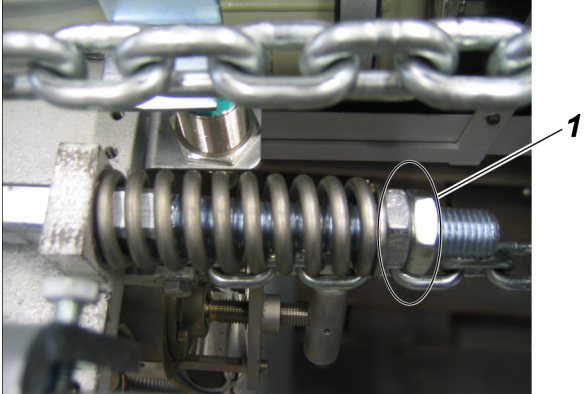

Step	Procedure
1	Secure probe carriage with rope or chain from rolling away. <b>Note:</b> Ensure adequate loading capacity of rope/chain.
2	Relieve tensioning device <b>(1)</b> for tackle. 
3	Release tackle fasteners.
4	After releasing the lock, slowly move probe carriage to the desired position and secure again. <b>Note:</b> Make sure that the probe carriage cannot come loose and hit the end position without braking.
5	Perform desired assembly work.
6	After completing work: Release lock, move probe carriage to original position and lock again.
7	Fasten both ends of the tackle again, avoid twisting the chain.
8	Tighten tensioning device.
9	Remove lock.

### Fine adjustment of the probe

After completing all installation tasks and start-up, it may be necessary to change the position of the gas sampling probe so as to ensure precise extension into and retraction out of the rotary kiln. Instructions are given in *Probe retractor: Checking and adjusting the position of the probe* on page 198. Make sure that the position indicator contact plates are firmly in place.

**Note:** During operation, the energy chain will hang down when the probe is in inserted position.

# Installing the control cabinet

Mechanical, thermal and material dangers



**Risk of injury in the area of the gas sampling system due to moving or falling parts, hot surfaces, anti-freeze, compressed air, lubricating oil**

Wear general personal protective equipment:

- ▶ Closed overalls with long trousers and long sleeves
- ▶ Safety shoes
- ▶ Safety gloves suitable for mechanical work
- ▶ Safety glasses
- ▶ Protective helmet
- ▶ If necessary, additional protective equipment if prescribed by the operator.

Heavy transport units



**Danger of crushing when lifting or lowering the transport unit**

- ▶ Only appropriately trained personnel may transport the transport units and only with the aid of the recommended transport equipment.
- ▶ Do not stand under suspended loads.
- ▶ Follow the transport instructions in these operating instructions carefully.

**Screws required for assembly**

- 4 galvanized steel screws (or stainless material) M10 or bolts M10

**Requirements**

The following requirements must be met in order to install the control cabinet:

- The site conforms to the designated site conditions (criteria see *Choosing the place of installation of the peripheral modules*).
- Fastening points are present to affix the control cabinet.
- The control cabinet is unpacked.

**Instructions**

How to install the control cabinet:

Step	Procedure
1	Fasten control cabinet in suitable position (see <i>Choosing the place of installation of the control cabinet</i> ) with 4 assembly screws or bolts.

# Installing the compressed-air supply

Mechanical, thermal and material dangers



**Risk of injury in the area of the gas sampling system due to moving or falling parts, hot surfaces, anti-freeze, compressed air, lubricating oil**

Wear general personal protective equipment:

- ▶ Closed overalls with long trousers and long sleeves
- ▶ Safety shoes
- ▶ Safety gloves suitable for mechanical work
- ▶ Safety glasses
- ▶ Protective helmet
- ▶ If necessary, additional protective equipment if prescribed by the operator.

**Position of the connections**

The location of the pneumatic connections on the probe retractor can be found in the pneumatic/hydraulic interface plan in the appendix. All required lines are pre-installed in the probe retractor area. All downline connections as connected from the central connection point on top of the probe retractor.

**Required documents**

- Pneumatic/hydraulic interface plan

**Assembly screws for compressed-air tank**

The following assembly screws are required for installation of the compressed-air tank:

- 3 galvanized steel screws (or stainless material) or bolts M12

**Requirements**

The following conditions must be met:

- Compressed air conforms to the required quality of compressed air; see *Power and compressed-air supply conditions*.
- When setting up the compressed-air tank: The site conforms to the designated site conditions (criteria see *Choosing the place of installation of the peripheral modules*).

**Connecting the compressed-air tank (optional)**

Proceed as follows to install the compressed-air tank:

Step	Procedure
1	Fasten compressed-air tank in suitable position (see <i>Choosing the place of installation of the compressed-air tank</i> ) with 3 galvanized steel screws (or stainless material) or bolts M12 on the ground.
2	Pneumatically connect compressed-air tank as per pneumatic/hydraulic interface plan (see appendix) to the gas sampling system.

**Connecting the compressed-air tubes**

Connect the compressed-air tubes as follows:

Step	Procedure
1	Cut the compressed-air tubes to length.
2	Lay and fasten compressed-air tubes along designated path.
3	Connect compressed-air tubes to the module screw connectors as per the pneumatic/hydraulic interface plan in the appendix.

**Preventing icing**

Make sure that the compressed-air supply cannot ice up in ambient temperatures below 0 °C, e.g. by installing auxiliary heating.

**Installing tubes**

Observe the following rules:

- Pneumatic connections must be installed so as to rule out any damage caused by working in the proximity of the sampling system. ABB recommends installing tubes on trays or in tube conduits.
- Minimum bending radius of the compressed-air tube is 100 mm. If this is not possible for technical reasons, ABB recommends installing suitable pipe adapters.

**Alternative mode of installing tubes**

You can run the tubes for the necessary pneumatic connections ("central compressed-air supply", "compressed-air tank flow", "compressed-air tank return") either via the central connection point of the probe retractor or directly to the screw connectors of the pneumatic box.

Run the tubes via the central connection area as follows:

Step	Procedure
1	Remove cover panels at rear of probe retractor.
2	Insert tubes in the existing cable/tube trough and fasten with cable ties.
3	Connect to the screw connectors.
4	Replace cover panels and screw in place.

## Installing the cooling module

### Mechanical, thermal and material dangers



**Risk of injury in the area of the gas sampling system due to moving or falling parts, hot surfaces, anti-freeze, compressed air, lubricating oil**

Wear general personal protective equipment:

- ▶ Closed overalls with long trousers and long sleeves
- ▶ Safety shoes
- ▶ Safety gloves suitable for mechanical work
- ▶ Safety glasses
- ▶ Protective helmet
- ▶ If necessary, additional protective equipment if prescribed by the operator.

### Heavy transport units



**Danger of crushing when lifting or lowering the transport unit**

- ▶ Only appropriately trained personnel may transport the transport units and only with the aid of the recommended transport equipment.
- ▶ Do not stand under suspended loads.
- ▶ Follow the transport instructions in these operating instructions carefully.

### Screws required for assembly

- 4 galvanized steel screws (or stainless material) M12x30 or bolts M12x30

### Requirements

The following requirements must be met in order to install the cooling module:

- The site conforms to the designated site conditions (criteria see *Choosing the place of installation of the peripheral modules*).
- Fastening points are present to affix the cooling module.
- The cooling module is unpacked.

**Instructions**

How to install the cooling module:

<b>Step</b>	<b>Procedure</b>
<b>1</b>	Fasten cooling module in suitable position (see <i>Choosing the place of installation of the cooling module</i> ) with 4 assembly screws or bolts on the ground.
<b>2</b>	Attach suitable drain pipe to safety valve outlet -J62 in order to prevent danger of cooling water escaping.

## Installing the cooling water circuit

Mechanical, thermal and material dangers

### **▲WARNING**

**Risk of injury in the area of the gas sampling system due to moving or falling parts, hot surfaces, anti-freeze, compressed air, lubricating oil**

Wear general personal protective equipment:

- ▶ Closed overalls with long trousers and long sleeves
- ▶ Safety shoes
- ▶ Safety gloves suitable for mechanical work
- ▶ Safety glasses
- ▶ Protective helmet
- ▶ If necessary, additional protective equipment if prescribed by the operator.

**Position of the connections**

The location of the connections on the various modules can be found in the pneumatic/hydraulic interface plan in the appendix. All required lines are pre-installed in the probe retractor area. All downline connections as connected from the central connection point on top of the probe retractor.

**Required documents**

- Pneumatic/hydraulic interface plan

**Tools required**

- Hose clamps

**Preparation**

Prepare the cooling-water hoses as follows:

Step	Procedure
1	After assembling the probe retractor and cooling module, determine the length of the cooling-water hoses.
2	Cut the cooling-water hoses to length.
3	Insert screw connectors into the ends of the hoses and secure with hose clamps.

**Installing the cooling-water hoses**

Install the cooling-water hoses as follows:

Step	Procedure
1	Lay and fasten cooling-water hoses along designated path.
2	Connect cooling-water hoses to the module screw connectors as per the pneumatic/hydraulic interface plan in the appendix.

**Installing tubes**

Observe the following rules:

- Install cooling-water hoses so as to rule out any damage caused by working in the proximity of the gas sampling system. ABB recommends installing tubes on trays or in tube conduits.
- Minimum bending radius of the cooling-water hoses is 160 mm. If this is not possible for technical reasons, ABB recommends installing suitable pipe adapters.

# Connecting the sample gas line to the retractor

Mechanical, thermal and material dangers



**Risk of injury in the area of the gas sampling system due to moving or falling parts, hot surfaces, anti-freeze, compressed air, lubricating oil**

Wear general personal protective equipment:

- ▶ Closed overalls with long trousers and long sleeves
- ▶ Safety shoes
- ▶ Safety gloves suitable for mechanical work
- ▶ Safety glasses
- ▶ Protective helmet
- ▶ If necessary, additional protective equipment if prescribed by the operator.

**Required documents**   ▪ Pneumatic/hydraulic interface plan

**Instructions**           How to connect the sample gas line to the analyzer system:

Step	Procedure
1	<p>The connector from the sample gas line to the probe retractor cable drag chain can be found in the pneumatic/hydraulic interface plan in the appendix. If further information is required on installation and connection to the analyzer system, consult the operating instructions of the analyzer system and analysis line.</p> <p><b>Note:</b> These tasks apply only to connection of the sample gas line to the analyzer system. The internal retractor sample gas line is delivered pre-installed.</p>

**Installation of the line**   Observe the following rules:

- Install sample gas line separately from other lines.
- When laying the sample gas line, avoid tight curves, bending or crossing other lines.
- Refer to the manufacturer's installation instructions for further details.



## Connecting internal electric cables

### Mechanical, thermal and material dangers

#### **WARNING**

**Risk of injury in the area of the gas sampling system due to moving or falling parts, hot surfaces, anti-freeze, compressed air, lubricating oil**

Wear general personal protective equipment:

- ▶ Closed overalls with long trousers and long sleeves
- ▶ Safety shoes
- ▶ Safety gloves suitable for mechanical work
- ▶ Safety glasses
- ▶ Protective helmet
- ▶ If necessary, additional protective equipment if prescribed by the operator.

### Current-carrying components

#### **DANGER**

**Danger of electric shock when working on electric components**

- ▶ Only specialized electrical personnel may work on the electrical system.
- ▶ Disconnect the gas sampling system from the power supply before working on the electrical components.
- ▶ Observe national regulations pertaining to electrical equipment.

### Position of the connections

The location of the electric connections on the various modules can be found in the electrical connection plan in the appendix. All required lines are pre-installed in the probe retractor area. All downline connections are installed via the central connection point to the electrical terminal box.

### Required documents

- Electrical connection plan

## Instructions

Proceed as follows to connect internal electric lines:

Step	Procedure
1	On the control cabinet: Turn off the main switch.
2	<p>Install internal lines in accordance with the electrical connection plan (see appendix). This applies to:</p> <ul style="list-style-type: none"> <li>▪ 24 VDC control cabinet-cooling module line</li> <li>▪ 230/400 VAC cable to cooling-water pump</li> <li>▪ 230/400 VAC cable to heat exchanger fan motor</li> <li>▪ 24 VDC cable to probe retractor</li> <li>▪ 24/26/28/30 VAC cable to probe retractor (option "H")</li> <li>▪ 230 VAC cable to probe heating (option "60S")</li> <li>▪ 230 VAC cable to probe retractor</li> <li>▪ Signal cable to analyzer cabinet</li> <li>▪ System bus cable control cabinet - cooling module (see step 3)</li> <li>▪ System bus cable probe retractor - cooling module (see step 3)</li> </ul>
3	<p>Connecting the system bus cable:</p> <ul style="list-style-type: none"> <li>▪ Install system bus cable from control cabinet to cooling module terminal box. Connect to the 9-pin D-Sub connector of the CAN bridge <b>(1)</b>.</li> <li>▪ Install system bus cable from the probe retractor terminal box to the cooling module terminal box. Connect to the 9-pin D-Sub connector of the CAN bridge <b>(2)</b>.</li> </ul> <div data-bbox="614 958 1021 1368" style="text-align: center;"> </div>
4	<p>Connecting the system bus cable to the frequency converter:</p> <ul style="list-style-type: none"> <li>▪ Loosen the short system bus cable with T-piece <b>(2)</b> from its transport fixing and connect it to the CAN adapter <b>(1)</b> at the frequency converter.</li> </ul> <div data-bbox="614 1529 694 1599" style="text-align: center;"> </div>

## Connecting external electric cables

### Mechanical, thermal and material dangers

#### **WARNING**

**Risk of injury in the area of the gas sampling system due to moving or falling parts, hot surfaces, anti-freeze, compressed air, lubricating oil**

Wear general personal protective equipment:

- ▶ Closed overalls with long trousers and long sleeves
- ▶ Safety shoes
- ▶ Safety gloves suitable for mechanical work
- ▶ Safety glasses
- ▶ Protective helmet
- ▶ If necessary, additional protective equipment if prescribed by the operator.

### Current-carrying components

#### **DANGER**

**Danger of electric shock when working on electric components**

- ▶ Only specialized electrical personnel may work on the electrical system.
- ▶ Disconnect the gas sampling system from the power supply before working on the electrical components.
- ▶ Observe national regulations pertaining to electrical equipment.

### Using the Ethernet Interface

#### **CAUTION**

The control unit of the sampling system is equipped with an Ethernet interface. This interface is intended solely for service purposes. Any other use is not allowed.

When using the Ethernet interface, external influences through the network connection can disturb the time characteristics of the control program and thus of the complete sampling system.

### Position of the connections

The location of the electric connections on the various modules can be found in the electrical connection plan in the appendix.

### Required documents

- Electrical connection plan

### Requirements

The following conditions must be met before connecting the power supply lines:

- Check that the voltage setting of the analyzer system matches the mains voltage.
- Make sure the power supply leads have an adequately dimensioned protective device (circuit breaker).

## Instructions

Proceed as follows to connect power supply lines:

Step	Procedure
1	On the control cabinet: Turn off the main switch.
2	<p data-bbox="608 286 1348 349">Affix ground cable to ground bolt of control cabinet (1), cooling module (2) and probe retractor (3).</p> <div data-bbox="614 362 1385 674" style="text-align: center;"> </div> <p data-bbox="608 687 1409 750">In order to ground the control cabinet, run the ground cable through cable connection M16 (4) on the side wall of the control cabinet:</p> <div data-bbox="614 761 1007 1117" style="text-align: center;"> </div>
3	<p data-bbox="608 1137 1409 1200">Install external electric lines in accordance with the specifications of the electrical connection plan (see appendix). This applies to:</p> <ul style="list-style-type: none"> <li data-bbox="608 1205 959 1236">▪ 230/400 VAC supply cable</li> <li data-bbox="608 1240 1086 1272">▪ UPS supply cable 230 VAC (optional)</li> <li data-bbox="608 1276 1198 1308">▪ Signal cable for movable protective installation</li> <li data-bbox="608 1312 1098 1344">▪ Signal cable for external warning horn</li> <li data-bbox="608 1348 963 1379">▪ System status signal cable</li> <li data-bbox="608 1384 1318 1415">▪ Profibus cable to analyzer cabinet (option "Profibus DP")</li> <li data-bbox="608 1420 1225 1451">▪ Modbus cable to analyzer cabinet (option "ACX")</li> </ul>

### Connection option for movable protective installation

The gas sampling system is fitted with an electric signal input that allows you to integrate an external protective installation to secure the danger area around the retractor. To do so, connect the appropriate switching output of the movable protective installation to the signal input (-X33 5/6 in the electrical connection plan).

### Connection option for air cannon

In order to prevent dangers caused by a blast of air from an air cannon in the area of the wall tube, the air cannon must be integrated into the gas sampling system control system (see *Integrating the air cannon into the control system*). The control cabinet is fitted with an air cannon connector (-D32 64 in the electrical connection plan).

**Connection option for additional warning horn** The control cabinet is fitted with a connector for an additional warning horn (-X33 7/8 in the electrical connection plan).

**Connection option for additional EMERGENCY-STOP switch** In addition to the integrated EMERGENCY-STOP switch, the probe retractor is fitted with a connector for an additional EMERGENCY-STOP switch. As delivered, both connectors are jumpered (see Detail "A" in pneumatic/hydraulic interface plan). To connect an additional EMERGENCY-STOP switch, remove the jumper and connect the connection wires to the EMERGENCY-STOP switch.



Topic	Page
Overview: Start-up .....	112
Installation check .....	113
Preparing the cooling-water circuit .....	114
Preparing the compressed-air supply .....	116
Activation .....	118
After switching on: working on the cooling module .....	121
Checking the pneumatic system.....	123
Starting frequency converter and adapting control parameters .....	124
Checking/correcting operating parameters .....	127
Checks to perform when using probe H .....	128
Inserting the probe and switching to automatic mode .....	131

## Overview: Start-up

### Instructions

Proceed as follows to start up the gas sampling system:

Step	Procedure	Instructions in ...
1	Check installation for proper condition.	<i>Installation check</i> on page 113
2	Fill cooling water and check water-tightness of the cooling-water circuit.	<i>Preparing the cooling-water circuit</i> on page 114
3	Check enclosed compressed-air supply, fill oiler.	<i>Preparing the compressed-air supply</i> on page 116
4	Switch on the gas sampling system.	<i>Activation</i> on page 118
5	After switching on: vent cooling-water circuit.	<i>After switching on: Working on the cooling module</i> on page 121
6	Check pneumatic system with the aid of the compressed-air switch in the pneumatic box.	<i>Checking the pneumatic system</i> on page 123
7	In the control cabinet: check frequency converter settings and correct if necessary.	<i>Checking frequency converter settings</i> on page 124
8	Check operating parameters of the gas sampling system and correct if necessary.	<i>Checking/correcting operating parameters</i> on page 127
9	Only if using probe H: <ul style="list-style-type: none"> <li>▪ check current monitoring relay settings.</li> <li>▪ Check probe heating power supply.</li> </ul>	<i>Checks to perform when using probe H</i> on page 128
10	Insert the probe for the first time, then adjust the speed of the probe during operation, adjust oil delivery rate on the compressed-air oiler, and check direction of rotation of the heat exchanger.	<i>Inserting the probe and switching to automatic mode</i> on page 131



## Installation check

Mechanical, thermal and material dangers



**Risk of injury in the area of the gas sampling system due to moving or falling parts, hot surfaces, anti-freeze, compressed air, lubricating oil**

Wear general personal protective equipment:

- ▶ Closed overalls with long trousers and long sleeves
- ▶ Safety shoes
- ▶ Safety gloves suitable for mechanical work
- ▶ Safety glasses
- ▶ Protective helmet
- ▶ If necessary, additional protective equipment if prescribed by the operator.

**Meaning**

Check the installation for correct condition before start-up. The following section describes this procedure. If one of these requirements is not met, abort start-up and do not continue until the appropriate conditions have been created.

**Instructions**

How to check the installation:

Step	Procedure
1	Based on the checklist below, check whether the gas sampling system was installed correctly.
2	Only continue to start up the gas sampling system once all conditions have been met.

**Checklist**

The following conditions must be met:

Conditions	OK
No visible damage to the modules.	
Connection and laying of electric lines checked.	
Connection and laying of pneumatic lines checked.	
Connection and laying of cooling-water lines checked.	
Heat exchanger connected with a shielded cable.	
Adherence to the bending radii of the installed lines and hoses checked.	
Stable fastening of the modules checked.	
Protective probe box fitted.	

## Preparing the cooling-water circuit

Mechanical, thermal and material dangers

**▲ WARNING**

**Risk of injury in the area of the gas sampling system due to moving or falling parts, hot surfaces, hot cooling water, anti-freeze, compressed air, lubricating oil**

Wear general personal protective equipment:

- ▶ Closed overalls with long trousers and long sleeves
- ▶ Safety shoes
- ▶ Safety gloves suitable for mechanical work
- ▶ Safety glasses
- ▶ Protective helmet
- ▶ If necessary, additional protective equipment if prescribed by the operator.

Slippery floor

**▲ CAUTION**

**Risk of falling on slippery floor due to escaped or spilled cooling water and lubricating oil or dirt**

- ▶ Always keep the floor around the gas sampling system clean and dry.

Harmful anti-freeze

**▲ CAUTION**

**Danger of injury to skin and eyes in the event of contact with cooling water or anti-freeze**

- ▶ Avoid contact with the cooling water and the anti-freeze.
- ▶ Wash any cooling water and anti-freeze off the skin immediately with water and soap.
- ▶ If cooling water or anti-freeze gets in the eyes despite protective glasses, rinse them thoroughly under running water, holding the eyelids open.
- ▶ Observe instructions in the anti-freeze manufacturer's safety data sheet.

Cooling-water requirements

The closed cooling-water circuit must be filled with approx. 50 l potable water (do not use anti-corrosive). In ambient temperatures below 0 °C use approx. 20 l anti-freeze. ABB recommends Glykol as anti-freeze. Anti-freeze with anti-corrosive additive is not permitted.

Ensuring anti-freeze protection

If temperatures can be expected to fall below 0 °C, fill the cooling-water circuit with anti-freeze before filling the cooling water:

Step	Procedure
1	Open filler on cooling module and fill approx. 20 l anti-freeze.

**Instructions: topping up cooling water**

Proceed as follows (note: it is advisable for two people to perform this work):

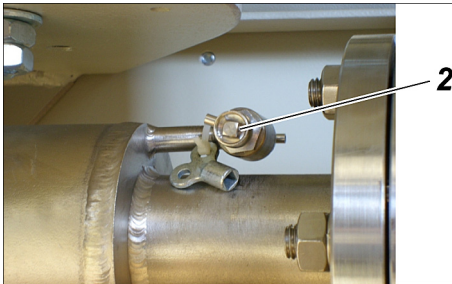
Step	Procedure
1	<p>Connect the filling pipe to the cooling-water supply of the cooling module.</p> <p><b>Note:</b> Make sure that there are no dirt deposits in the filling pipe; rinse first.</p> <p><b>Note:</b> The cooling water is tinted due to formation of metal oxides in the heat exchanger. The functional capability is not affected.</p> <p><b>Note:</b> Cooling water filling pressure &gt; 1 bar (1000 hPa).</p>
2	<p>On the top of the heat exchanger: Unscrew cap on drain valve and open vent cock (red).</p> 
3	<p>Open drain valves (2) on gas sampling probe.</p> 
4	<p>Slowly open the shut-off valve -J63 on the cooling module and allow cooling water to flow in until cooling water appears at the drain valves of the heat exchanger and gas sampling probe.</p>
5	<p>Close shut-off valve -J63.</p>
6	<p>Close drain valves on heat exchanger and gas sampling probe.</p>
7	<p>Check pressure of cooling water in the controller and top up if necessary (target cooling water pressure in cooled state: 1-1.5 bar (1000-1500 hPa)).</p>

**Instructions: check for leaks**

Proceed as follows:

Step	Procedure
1	<p>Check cooling water circuit for leaks. Remedy any leaks before continuing with start-up.</p>

## Preparing the compressed-air supply

Mechanical, thermal and material dangers

**▲ WARNING**

**Risk of injury in the area of the gas sampling system due to moving or falling parts, hot surfaces, hot cooling water, anti-freeze, compressed air, lubricating oil**

Wear general personal protective equipment:

- ▶ Closed overalls with long trousers and long sleeves
- ▶ Safety shoes
- ▶ Safety gloves suitable for mechanical work
- ▶ Safety glasses
- ▶ Protective helmet
- ▶ If necessary, additional protective equipment if prescribed by the operator.

Harmful lubricating oil

**▲ CAUTION**

**Danger due to skin and eye injuries in the event of contact with lubricating oil from the pneumatic box of, from the filter muffler or from inside the pneumatic motor.**

- ▶ Avoid contact with lubricating oil.
- ▶ Wash any lubricating oil off the skin immediately with water and soap.
- ▶ If any lubricating oil gets in the eyes despite protective glasses, rinse them thoroughly under running water, holding the eyelids open.
- ▶ Observe instructions in the lubricating oil manufacturer's safety data sheet.

Lubricating oil requirements

Lubricating oil "D" DIN 51502, kinematic viscosity 30 mm<sup>2</sup>/s(cST) at 40 °C (ISO VG 32, DIN 51519)

Compressed-air requirements

The compressed air must meet the following minimum requirements:

<b>Dew point</b>	+3 °C
<b>Pressure</b>	6 bar (6000 hPa) positive pressure
<b>Consumption</b>	approx. 3 m <sup>3</sup> /h

One probe travel (2 x 20 s) requires approx. 1 m<sup>3</sup>.

Other requirements are:

- The compressed air must be free of dirt and oil/water droplets.
- At ambient temperatures below 0 °C make sure that the compressed-air supply cannot freeze.

**Checking compressed-air supply**

Proceed as follows to check the compressed air:

Step	Procedure
1	Check the quality of the compressed air at the connection to the customer-side compressed-air system using a white cloth (see compressed-air specifications above). If you observe any oil, moisture or other impurities, abort start-up and do not continue until these residues have been permanently eliminated.

**Filling the compressed-air oiler**

Fill the compressed-air oiler before switching on the gas sampling system:

Step	Procedure
1	Shut off the compressed-air using the gate valve <b>(1)</b> in the pneumatic box of the probe retractor. <div data-bbox="564 645 1059 1155" data-label="Image"> </div>
2	Completely drain the compressed-air tank (if present).
3	Unscrew the tank on the compressed-air oiler -J74 by turning it counter-clockwise, fill suitable oil to the top quarter in the top inspection window and screw tank back on. <div data-bbox="558 1319 896 1771" data-label="Image"> </div>
4	Remove any oil residue with a cloth.
5	Open the compressed-air gate valve <b>(1)</b> again.

## Activation

### Mechanical, thermal and material dangers

#### **WARNING**

**Risk of injury in the area of the gas sampling system due to moving or falling parts, hot surfaces, hot cooling water, anti-freeze, compressed air, lubricating oil**

Wear general personal protective equipment:

- ▶ Closed overalls with long trousers and long sleeves
- ▶ Safety shoes
- ▶ Safety gloves suitable for mechanical work
- ▶ Safety glasses
- ▶ Protective helmet
- ▶ If necessary, additional protective equipment if prescribed by the operator.

### Current-carrying components

#### **DANGER**

**Danger of electric shock when control cabinet is open, open connection or terminal boxes**

- ▶ Only specialized electrical personnel may work on the electrical system.
- ▶ Observe national regulations pertaining to electrical equipment.

### Gas sampling probe movements

#### **WARNING**

**Risk of crushing around the retractor due to gas sampling probe movements**

- ▶ Do not stand in the danger area around the retractor.
- ▶ Press the EMERGENCY-STOP switch immediately if anyone is still in the danger area around the retractor after the warning lamps light up or the warning buzzer buzzes.

### Requirements

- The connected analyzer system must be switched on. Observe the warm-up time of the analyzer system.
- The mechanical locking bar of the shutter must be removed before inserting the gas sampling probe for the first time.
- The system must not have any visible damage (see also *Checking general condition* on page 140).
- The customer-side central compressed-air supply is switched on.

### Tools required

- Control cabinet key to open the control cabinet

**Switching on the gas sampling system.**

Proceed as follows to switch on the gas sampling system:

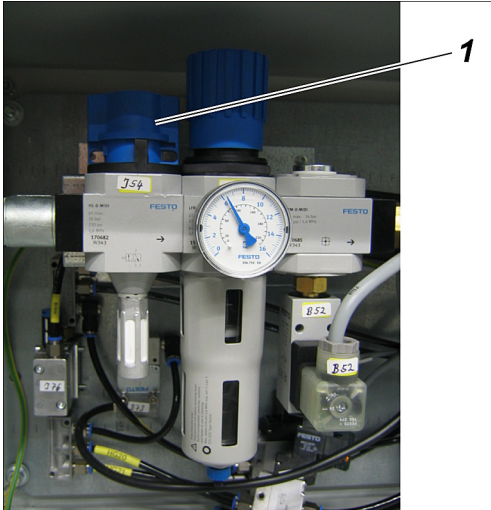
Step	Procedure
1	<p>Shut off the compressed-air using the gate valve <b>(1)</b> in the pneumatic box of the probe retractor so as to prevent any undesirable probe movements.</p> 
2	Completely vent the compressed-air tank (if present).
3	Open the control cabinet.
4	Turn on the main switch of the gas sampling system.
5	Switch on uninterruptible power supply (if present).
6	Switch on residual current circuit-breaker in the control cabinet (if present).
7	Flip the fuse switches one by one in the control cabinet.
8	Wait for controller to boot.
9	Start frequency converter.
10	Adjust local time (password for "Advance Service" required). <b>Path:</b> Setup ► System ► Time setting
11	<p>Open the compressed-air gate valve <b>(1)</b> again.</p> <p><b>WARNING!</b> Depending on the current position, the probe begins to move towards to the rear end position (probe completely retracted). <b>Do not stand in the area of travel of the probe or probe carriage.</b></p>
12	<p>Switch on the cooling-water pump on the touchscreen.</p> <p><b>Path:</b> Operation ► Cooling Water Pump ► ON</p>
13	<p>Wait for the heated modules to heat up until the following error messages disappear:</p> <p>"Probe heating temperature MIN" "Cable Drag Chain Sample Gas Line Temp. Error"</p> <p><b>Path:</b> Diagnosis ► Message</p>
14	<p>Turn service switch to <i>ON</i> position.</p> <p><b>Note:</b> This step resets various safety functions.</p>

<b>15</b>	Turn service switch to <i>OFF</i> position. <b>Result:</b> The gas sampling system is in manual mode.
<b>16</b>	Perform the following checks to ensure smooth operation of the gas sampling system before inserting the gas sampling probe for the first time: <ul style="list-style-type: none"> <li>▪ <i>After switching on: Working on the cooling module</i> on page 121</li> <li>▪ <i>Checking the pneumatic system</i> on page 123</li> <li>▪ <i>Checking frequency converter settings</i> on page 124</li> <li>▪ <i>Checking/correcting operating parameters</i> on page 127</li> <li>▪ <i>Checks to perform when using probe H</i> on page 128</li> </ul>
<b>17</b>	Close the control cabinet.



## After switching on: working on the cooling module

### Mechanical, thermal and material dangers

#### **WARNING**

**Risk of injury in the area of the gas sampling system due to moving or falling parts, hot surfaces, hot cooling water, anti-freeze, compressed air, lubricating oil**

Wear general personal protective equipment:

- ▶ Closed overalls with long trousers and long sleeves
- ▶ Safety shoes
- ▶ Safety gloves suitable for mechanical work
- ▶ Safety glasses
- ▶ Protective helmet
- ▶ If necessary, additional protective equipment if prescribed by the operator.

### Current-carrying components

#### **DANGER**

**Danger of electric shock when control cabinet is open, open connection or terminal boxes**

- ▶ Only specialized electrical personnel may work on the electrical system.
- ▶ Observe national regulations pertaining to electrical equipment.

### Harmful anti-freeze

#### **CAUTION**

**Danger of injury to skin and eyes in the event of contact with cooling water or anti-freeze.**

- ▶ Avoid contact with the cooling water and the anti-freeze.
- ▶ Wash any cooling water and anti-freeze off the skin immediately with water and soap.
- ▶ If cooling water or anti-freeze gets in the eyes despite protective glasses, rinse them thoroughly under running water, holding the eyelids open.
- ▶ Observe instructions in the anti-freeze manufacturer's safety data sheet.

### Slippery floor

#### **CAUTION**

**Risk of falling on slippery floor due to escaped or spilled cooling water and lubricating oil or dirt**

- ▶ Always keep the floor around the gas sampling system clean and dry.

### Tools required

- Control cabinet key to open the control cabinet

### Requirements

The service switch is in the *ON* position, the gas sampling probe is retracted from the kiln (see *Operating the service switch* on page 159).

**Instructions: venting the cooling-water circuit**

Proceed as follows:

Step	Procedure
1	Open the control cabinet.
2	Switch off the cooling-water pump at the motor breaker <b>-F37 (1)</b> . <div data-bbox="614 331 1161 734" style="text-align: center;"> </div> <p data-bbox="606 750 1348 806"><b>Note:</b> You can also switch off the cooling-water pump at circuit breaker <b>-F36 (2)</b>.</p>
3	Wait 5 minutes.
4	On the top of the heat exchanger: Unscrew cap on drain valve and open vent cock (red) so that air can escape.
5	Close drain valve on heat exchanger again as soon as only cooling water comes out of the drain valve.
6	Slowly open drain valve on the gas sampling probe.
7	Close drain valve on gas sampling probe again as soon as only cooling water comes out of the drain valve.
8	Switch cooling-water pump <b>-M51</b> on again at motor breaker <b>-F37 (1)</b> or at circuit breaker <b>-F36 (2)</b> for approx. 20 s.
9	Wait 5 minutes, vent again.
10	Repeat step <b>8</b> through <b>9</b> if necessary until no more air comes out of the cooling-water circuit.
11	Check pressure of cooling water and top up if necessary (target cooling water pressure in cooled state: 1-1.5 bar (1000-1500 hPa)).
12	Close control cabinet again.

**Note:** Severe fluctuations of the cooling-water flow rate indicate that the cooling-water circuit needs to be vented again.

# Checking the pneumatic system

Mechanical, thermal and material dangers



**Risk of injury in the area of the gas sampling system due to moving or falling parts, hot surfaces, hot cooling water, anti-freeze, compressed air, lubricating oil**

Wear general personal protective equipment:

- ▶ Closed overalls with long trousers and long sleeves
- ▶ Safety shoes
- ▶ Safety gloves suitable for mechanical work
- ▶ Safety glasses
- ▶ Protective helmet
- ▶ If necessary, additional protective equipment if prescribed by the operator.

## Requirements

The service switch is in the *ON* position, the gas sampling probe is retracted from the kiln (see *Operating the service switch* on page 159).

## Instructions

Proceed as follows to check compressed-air settings before first insertion.

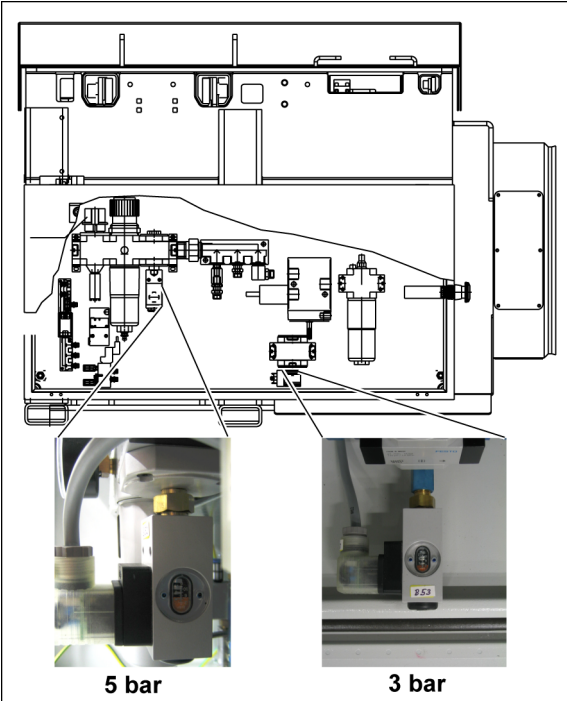
Step	Procedure
1	Check the compressed-air system with suitable equipment, see <i>Checking for leaks</i> on page 171.
2	<p>Check the pressure switches in the pneumatic box for correct settings (5 bar (5000 hPa) and 3 bar (3000 hPa); see Figure).</p> <div style="text-align: center;">  <p data-bbox="708 1688 767 1715">5 bar</p> <p data-bbox="995 1688 1054 1715">3 bar</p> </div> <p>Check mark in settings window and adjust with the setting screw on the head of the pressure switch if necessary.</p>

## Starting frequency converter and adapting control parameters

**Mechanical, thermal and material dangers**



**Risk of injury in the area of the gas sampling system due to moving or falling parts, hot surfaces, hot cooling water, anti-freeze, compressed air, lubricating oil**

Wear general personal protective equipment:

- ▶ Closed overalls with long trousers and long sleeves
- ▶ Safety shoes
- ▶ Safety gloves suitable for mechanical work
- ▶ Safety glasses
- ▶ Protective helmet
- ▶ If necessary, additional protective equipment if prescribed by the operator.

**Current-carrying components**



**Danger of electric shock when control cabinet is open, open connection or terminal boxes**

- ▶ Only specialized electrical personnel may work on the electrical system.
- ▶ Observe national regulations pertaining to electrical equipment.

**Meaning**

The frequency converter ACS355 controls the heat exchanger motor. In order to ensure constant cooling-water temperature, the factory-set default control parameters must be adapted to the conditions at the installation site.



Refer to the ACS355 manual for further information on operating the frequency converter.

**Tools required**

- Control cabinet key to open the control cabinet

**Requirements**

The following conditions must be met:

The service switch is in the *ON* position; the gas sampling probe is retracted from the kiln (see *Operating the service switch* on page 159).

## Instructions

Proceed as follows to start the frequency converter and adapt the control parameters:

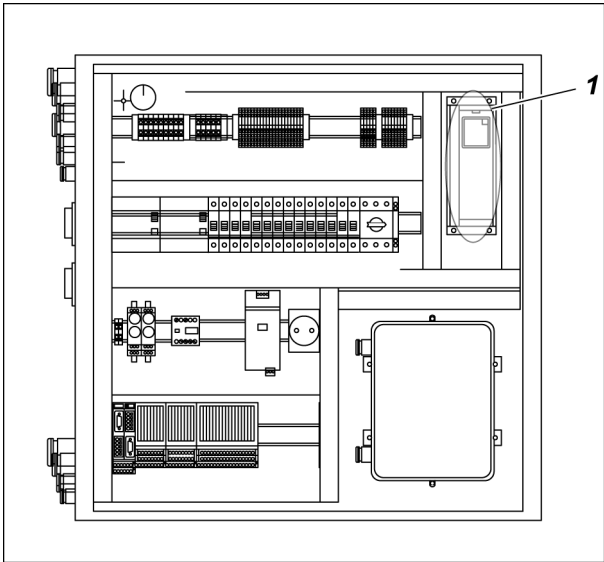
Step	Procedure
1	Open the control cabinet.
2	<p>In the control cabinet: Start the frequency converter ACS 355 (1) by pressing the START button.</p> <p>Check whether "REM" (for remote mode) is indicated on the left side of the display and change by pressing the LOC REM button if required.</p> <p><b>Result:</b> The frequency converter displays "A5011" for approx. 2 seconds.</p>  <p><b>Note:</b> The frequency converter must be restarted after each system power failure. The following steps 3 to 10 must be executed only during the first system start-up and not after a system power failure.</p>
3	Close control cabinet.
4	Turn service switch to OFF position.
5	Insert probe.
6	<p>Monitor cooling water return temperature.</p> <p><b>Path:</b> Diagnosis ► Trends ► Cooling water return</p> <p><b>Note:</b> If the set points are exceeded due to inadequate adaptation of the control parameters, the program sequences for the protection of the probe are started automatically.</p>
7	<p>Adjust control parameter KP in small steps until the cooling water return temperature runs as constant as possible (default: -2).</p> <p><b>Path:</b> Setup ► FC parameters</p> <p><b>Note:</b> Enter the KP value always negative using the +/- button.</p>
8	Adjust control parameter KI to further optimize the temperature run (TN, default: 10).
9	If necessary, also adjust control parameter KD (TV, default: 0).

<b>Step</b>	<b>Procedure</b>
<b>10</b>	Save control parameter settings using the  button.

## Checking/correcting operating parameters

### Modifying the SCK controller operating parameters

The gas sampling system control system has factory settings that need to be modified to specific system conditions at start-up. You can edit alarm limits in a set range to suit specific system conditions. Limited configuration serves to protect the probe retractor against harmful or contradictory settings. A list of operating parameters can be found in *Default operating parameter settings* on page 50. You can display the operating parameters on the control cabinet touchscreen (Setup ► Time Parameters, Setup ► Limit Parameters, Setup ► Basic Parameters). Refer to *Optimizing operating parameters* on page 53 for details on editing operating parameters.

## Checks to perform when using probe H

### Current-carrying components



#### Danger of electric shock when control cabinet is open, open connection or terminal boxes

- ▶ Only specialized electrical personnel may work on the electrical system.
- ▶ Observe national regulations pertaining to electrical equipment.

### Meaning

In addition to the usual checks when starting up the probe for the first time, additional checks are required when using probe H.

These are:

- Checking current monitoring relay settings
- Checking probe H heating power supply

### Position

The following illustration shows the position of current monitoring relays -K35 and -K36 in the control cabinet:

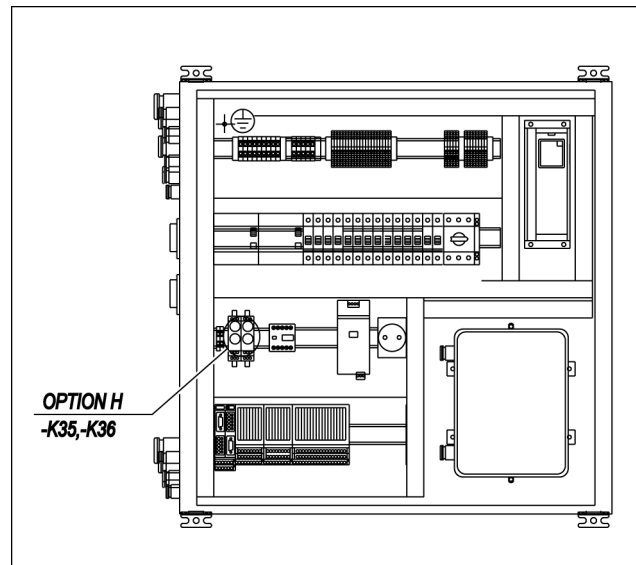

### Tools required

- Control cabinet key to open the control cabinet

### Requirements

The following conditions must be met:

The service switch is in the *ON* position, the gas sampling probe is retracted from the kiln (see *Operating the service switch* on page 159).



## Checking current monitoring relays

How to check the current monitoring relays for correct settings:

Step	Procedure																
1	Open the control cabinet.																
2	<p>Check current monitoring relays -K35 and -K36 for correct settings.</p> <p><b>Settings for -K35 and -K36:</b></p> <table><tbody><tr><td>Hysteresis</td><td>5%</td></tr><tr><td>Threshold</td><td>4,5 A</td></tr><tr><td>Tripping delay</td><td>0,1 s</td></tr><tr><td>Start-up delay</td><td>5 s</td></tr></tbody></table> <p>There is a DIP switch under the white flap. Check the following settings here:</p> <table><tbody><tr><td>1 Undercurrent monitoring</td><td>ON</td></tr><tr><td>2 NC contact operation</td><td>ON</td></tr><tr><td>3 Storage off</td><td>OFF</td></tr><tr><td>4 (Default)</td><td>OFF</td></tr></tbody></table>	Hysteresis	5%	Threshold	4,5 A	Tripping delay	0,1 s	Start-up delay	5 s	1 Undercurrent monitoring	ON	2 NC contact operation	ON	3 Storage off	OFF	4 (Default)	OFF
Hysteresis	5%																
Threshold	4,5 A																
Tripping delay	0,1 s																
Start-up delay	5 s																
1 Undercurrent monitoring	ON																
2 NC contact operation	ON																
3 Storage off	OFF																
4 (Default)	OFF																
3	Close the control cabinet.																

**Checking the probe H heating power supply**

The electric heating of probe H is driven by a fixed voltage generated by the transformer installed in the control cabinet. Excessively long supply lines or incorrectly chosen cross-sections of the supply lines can lead to massive voltage drops en route to the gas sampling probe. This leads to reduced heating output and problems with probe operation.

Proceed as follows:

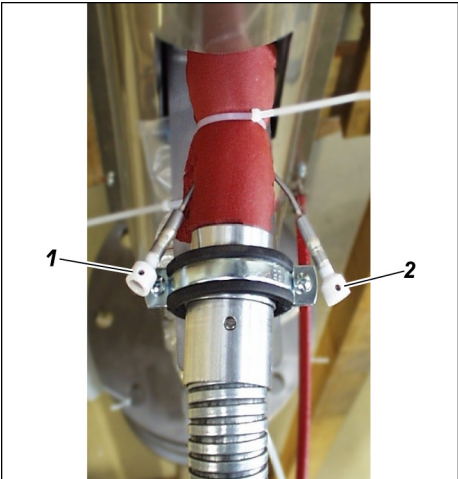
Step	Procedure												
<p><b>1</b></p>	<p>Check voltage between Ground and the probe-side terminal connections <b>(1)</b> or <b>(2)</b>.</p> 												
<p><b>2</b></p>	<p>The following minimum values must be reached:</p> <table border="1" data-bbox="616 1021 1267 1099"> <tr> <td>Probe length / m</td> <td>1,5</td> <td>2</td> <td>2,5</td> <td>3</td> <td>3,5</td> </tr> <tr> <td>Minimum voltage / V</td> <td>24</td> <td>26</td> <td>26</td> <td>28</td> <td>30</td> </tr> </table> <p>If these values are not reached, the system must not be put into operation in this set-up as adequate heating of the integrated metal filter cannot be guaranteed and this may lead to condensation and clogging of the probe.</p> <p>Check the following possibilities for adequate supply:</p> <ul style="list-style-type: none"> <li>▪ Lay larger cross-sections</li> <li>▪ Reduce lengths of supply lines</li> </ul>	Probe length / m	1,5	2	2,5	3	3,5	Minimum voltage / V	24	26	26	28	30
Probe length / m	1,5	2	2,5	3	3,5								
Minimum voltage / V	24	26	26	28	30								

## Inserting the probe and switching to automatic mode

Mechanical, thermal and material dangers

### **WARNING**

**Risk of injury in the area of the gas sampling system due to moving or falling parts, hot surfaces, anti-freeze, compressed air, lubricating oil**

Wear general personal protective equipment:

- ▶ Closed overalls with long trousers and long sleeves
- ▶ Safety shoes
- ▶ Safety gloves suitable for mechanical work
- ▶ Safety glasses
- ▶ Protective helmet
- ▶ If necessary, additional protective equipment if prescribed by the operator.

Gas sampling probe movements

### **WARNING**

**Risk of crushing around the retractor due to gas sampling probe movements**

- ▶ Before commencing any work on the gas sampling system, turn the service switch to "ON" and secure the service switch against unauthorized switching (with a padlock).
- ▶ Additionally press the EMERGENCY-STOP switch before working on the retractor or probe.
- ▶ Do not enter the danger area around the retractor until it is at standstill and the warning lamps and buzzer are off.
- ▶ Never stand in the danger area around the retractor when the protective installation is closed.
- ▶ When the warning lamps light up or the warning buzzer buzzes, leave the danger area around the probe retractor immediately as the probe is about to move at any moment.
- ▶ Press the EMERGENCY-STOP switch immediately if anyone is still in the danger area around the retractor after the warning lamps light up or the warning buzzer buzzes.

Requirements

The following conditions must be met:

The service switch is in the *ON* position, the gas sampling probe is retracted from the kiln (see *Operating the service switch* on page 159).

Instructions:  
Inserting the probe  
for the first time

Proceed as follows:

Step	Procedure
1	Make sure that the mechanical locking bar of the shutter is removed.
2	Check wall tube for clogging and clean if necessary. <b>Note:</b> Inserting the gas sampling probe when the duct opening is clogged can lead to damage to the probe and is therefore not permitted.
3	Leave danger area around the retractor, close protective installation and turn service switch to <i>OFF</i> position.

Step	Procedure
4	<p>Insert the gas sampling probe into the kiln using the touchscreen.</p> <p><b>Path:</b> Operation ► Probe ► Probe Action ► Insert</p> <p>Observe the following:</p> <ul style="list-style-type: none"> <li>▪ horizontal and vertical alignment of the gas sampling probe in relation to the opening in the mounting flange</li> <li>▪ stability of the probe retractor fastening elements</li> <li>▪ unobstructed mobility of all cable and hose connections</li> <li>▪ even movement of the probe carriage</li> </ul>
5	<p>Wait for cooling water to heat up: After inserting the probe, the gas sampling system has a warm-up time to reach the necessary operating temperature. The <i>Measured Value on Hold</i> signal is only reset once the cooling temperature reaches a minimum temperature of 50 °C. Once this signal is active, make sure that no sample gas is sucked in by the gas sampling probe.</p>
6	<p>Switch the gas sampling probe to automatic mode using the touchscreen.</p> <p><b>Path:</b> Operation ► Automatic on / off</p>

**Result:** The sampling system is thus in automatic mode and monitors itself.

**Instructions: Setting probe carriage speed**

After switching on the gas sampling system there may be differences in probe retractor travel speed depending on the capacity of the compressed-air supply provided by the customer. The travel time for one insertion/retraction of the gas sampling probe must be approx. 20 seconds. You can adjust travel speed as follows:

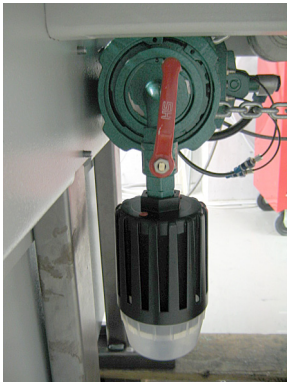
Step	Procedure
1	<p>Turn service switch to <i>ON</i> position.</p> <p><b>WARNING!</b> The probe moves out of the kiln. <b>Do not stand in the area of travel of the probe or probe carriage.</b></p>
2	<p>Adjust travel speed to the desired setting using the ball valve on the compressed-air motor.</p> 
3	<p>Turn service switch back to <i>OFF</i> position and insert probe again using the controller.</p> <p><b>WARNING!</b> Probe moves into the kiln. <b>Do not stand in the area of travel of the probe or probe carriage until the probe is completely inserted into the kiln and the warning lamps go out.</b></p>

Step	Procedure
4	In controller: wait for heating-up time. "C. Water Return Temp. MIN" <b>Path:</b> Diagnosis ► Message
5	In controller: switch gas sampling probe to AUTOMATIC mode: <b>Path:</b> Operation ► Automatic on / off

**Instructions: setting the compressed-air oiler**

The compressed-air oiler must deliver approx. 2 drops of oil per insertion/retraction cycle. If this is not ensured, the compressed-air motor may get damaged or this may lead to excessive soiling of the muffler. How to change oil delivery quantity on the compressed-air oiler (**note:** two people should perform this job):

Step	Procedure
1	Turn service switch to <i>ON</i> position. <b>WARNING!</b> The probe moves out of the kiln. <b>Do not stand in the area of travel of the probe or probe carriage.</b>
2	Turn the setting screw in the inspection glass to modify the quantity of oil. Meaning of the directions of rotation: counter clockwise    more oil clockwise            less oil
	
3	Move probe in/out to check oil quantity, modify again if necessary.
4	Turn service switch back to <i>OFF</i> position and insert probe again using the controller. <b>WARNING!</b> Probe moves into the kiln. <b>Do not stand in the area of travel of the probe or probe carriage until the probe is completely inserted into the kiln and the warning lamps go out.</b>
5	In controller: wait for heating-up time. "C. Water Return Temp. MIN" <b>Path:</b> Diagnosis ► Message
6	In controller: switch gas sampling probe to AUTOMATIC mode: <b>Path:</b> Operation ► Automatic on / off

**Instructions:  
checking the  
direction of rotation  
of the heat exchanger**

After first insertion, check the direction of rotation of the rotor on the heat exchanger:

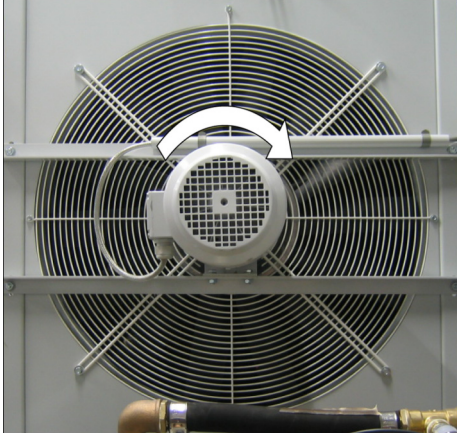
Step	Procedure
1	<p>The rotor must turn clockwise. If necessary, adjust the direction of rotation by changing the phase.</p> 

**Special case:  
calcinator gas outlet**

Owing to the greater flow speeds in this process, after start-up the gas sampling probe must be checked frequently for wear at the calcinator gas outlet measuring point. If distinct signs of wear are visible after a short time, check the installation position of the gas sampling probe. Failing to observe this can lead to severe damage or total loss of the gas sampling probe.

<b>Topic</b>	<b>Page</b>
Safety regulations for operation.....	136
Monitoring automatic mode .....	138
Checking general condition .....	140
Cleaning gas sampling probe H .....	142
Cleaning gas sampling probe 60S.....	144
Using the EMERGENCY-STOP switch.....	146

## Safety regulations for operation

### Introduction

The operator monitoring the gas sampling system must observe the following safety instructions.

### Mechanical, thermal and material dangers

#### **WARNING**

**Risk of injury in the area of the gas sampling system due to moving or falling parts, hot surfaces, hot cooling water, anti-freeze, compressed air, lubricating oil**

Wear general personal protective equipment:

- ▶ Closed overalls with long trousers and long sleeves
- ▶ Safety shoes
- ▶ Safety gloves suitable for mechanical work
- ▶ Safety glasses
- ▶ Protective helmet
- ▶ If necessary, additional protective equipment if prescribed by the operator.

### Gas sampling probe movements

#### **WARNING**

**Risk of crushing around the retractor due to gas sampling probe movements**

- ▶ Do not stand in the danger area around the retractor.
- ▶ Press the EMERGENCY-STOP switch immediately if anyone is still in the danger area around the retractor after the warning lamps light up or the warning buzzer buzzes.

### Current-carrying components

#### **DANGER**

**Danger of electric shock when touching electric components**

- ▶ Only specialized electrical personnel may work on the electrical system.
- ▶ If you are not specialized electrical personnel:
  - Never open electric components.
  - Never touch damaged electric components, cables or the inside of electric components.

### Hot surfaces

#### **WARNING**

**danger of burning due to hot surfaces during and after operation of the gas sampling system.**

- ▶ Do not touch the gas sampling system during and after operation.
- ▶ Do not touch the gas sampling system until it has cooled down to 50 °C. Specifically, do not touch
  - the cooling module,
  - the heated sample gas line,
  - the connection box for the heated sample gas line on the retractor,
  - the heated sampling filter,
  - the entire gas sampling probe,
  - the metal structure of the retractor,
  - the shutter of the duct opening.
- ▶ If it is unavoidable to touch hot components, wear a face mask against heat, heat-proof gloves and protective welder's clothing.



**Falling or spalling hot material**

**▲WARNING**

**Danger of burning due to material falling or spalling off the retracted probe**

- ▶ Never enter the danger area around the retractor during operation.
- ▶ Do not approach the retracted probe until it has cooled down.
- ▶ If it is unavoidable to approach the hot probe, wear a face mask against heat, heat-proof gloves and protective welder's clothing.

**Harmful gases, jet flames**

**▲WARNING**

**Danger due to harmful gases and jet flames in the area of the duct opening while the gas sampling probe is moving in or out**

- ▶ Never enter the danger area around the retractor during operation.
- ▶ Ensure adequate ventilation of the work place.

**Hot cooling water**

**▲WARNING**

**Risk of scalding when hot cooling water escapes from the cooling system in the event of a malfunction**

- ▶ Wait until the entire cooling water has been evacuated before approaching.

**Harmful anti-freeze**

**▲CAUTION**

**Danger of injury to skin and eyes in the event of contact with cooling water or anti-freeze.**

- ▶ Avoid contact with the cooling water and the anti-freeze.
- ▶ Wash any cooling water and anti-freeze off the skin immediately with water and soap.
- ▶ If cooling water or anti-freeze gets in the eyes despite protective glasses, rinse them thoroughly under running water, holding the eyelids open.
- ▶ Observe instructions in the anti-freeze manufacturer's safety data sheet.

**Harmful lubricating oil**

**▲CAUTION**

**Danger due to skin and eye injuries in the event of contact with lubricating oil from the pneumatic box of, from the filter muffler or from inside the pneumatic motor.**

- ▶ Avoid contact with lubricating oil.
- ▶ Wash any lubricating oil off the skin immediately with water and soap.
- ▶ If any lubricating oil gets in the eyes despite protective glasses, rinse them thoroughly under running water, holding the eyelids open.
- ▶ Observe instructions in the lubricating oil manufacturer's safety data sheet.

**Slippery floor**

**▲CAUTION**

**Risk of falling on slippery floor due to escaped or spilled cooling water and lubricating oil or dirt**

- ▶ Always keep the floor around the gas sampling system clean and dry.

## Monitoring automatic mode

### Introduction

After starting up the gas sampling system you can switch the gas sampling system to automatic mode. Automatic mode allows continuous operation of the system for sample gas sampling. Probe cleaning steps take place after defined intervals (these can be set using the controller).



Observe all safety instructions in the section *Safety regulations for operation on page 136* when performing this work.

### Requirements

The following conditions must be met for automatic mode:

- Gas sampling probe correctly installed and put into operation.
- The gas sampling probe is inserted into the kiln.

### Instructions

How to monitor the gas sampling system in automatic mode:

Step	Procedure
1	In controller: switch gas sampling probe to automatic mode (if this has not already been done). <b>Path:</b> Operation ► Automatic on / off
2	In controller: monitor operation of the gas sampling system in the diagnostic screens. The following parameters are relevant: <ul style="list-style-type: none"><li>▪ "Cooling Water Pressure"</li><li>▪ "Sample Gas Pressure"</li><li>▪ "Cooling Water Flow Rate"</li><li>▪ "Cooling Water Flow Temp."</li><li>▪ "Cooling Water Return Temp."</li><li>▪ "Probe Heating Temp."</li></ul> Observe the following rules in automatic mode: <ul style="list-style-type: none"><li>▪ In case of error signals: read the message on the touchscreen immediately and take appropriate action (<i>Errors on page 213</i>).</li><li>▪ Check general condition of the system (<i>Checking general condition on page 140</i>).</li></ul>

### Power failure

Failure of mains power leads to immediate retraction of the gas sampling probe out of the kiln. After switching the power supply back on, the display and operating unit boots and the sampling system switches to manual mode.

To resume normal measuring operation you must manually insert the gas sampling probe into the kiln and then switch to automatic mode (see section *Start-up on page 111*).

### Damage

If the gas sampling probe was installed in accordance with the recommendations in the Installation section and in the project planning documents, adequate protection of the probe is guaranteed in operation.

The probe (probe pipe and filter) may nevertheless get damaged, above all in the following situations:

- if material falls on the probe
- if too much material adheres to the probe pipe

- if tire parts or bullets hit the probe pipe
- if red-hot material flows over the probe
- if aggressive combustion residues corrode the probe pipe and filter material
- if the probe pipe material is worn by high flue gas speeds (particularly critical at flue gas speeds > 20 m/s)

The manufacturer offers no warranty for such damage.

### **SO<sub>2</sub> measurement**

The following problems may occur when measuring SO<sub>2</sub>:

- if the gas sampling hole on the tip of the probe clogs up with combustion particles, an increasing amount of SO<sub>2</sub> is absorbed,
- if a layer of rust particles builds up on the filter unit, SO<sub>2</sub> will also be absorbed as the sample gas travels to the analyzer,
- if the sample gas condenses in the sample gas tube, part of the SO<sub>2</sub> dissolves in the condensation, which in turn decreases the SO<sub>2</sub> concentration measured in the analyzer,

In the above-mentioned cases, the falsification of results will be all the more severe, the lower the concentration of SO<sub>2</sub>.

Maximum reliability of SO<sub>2</sub> measurement is given,

- when the gas sampling hole(s) on the probe tips are completely open (i.e. not clogged up with rust particles),
- immediately after blow-back.

Due to the propensity of rust particles to form incrustations on or inside the gas sampling system that may result in absorption of SO<sub>2</sub>, the manufacturer offers no warranty on such measurements.

### **Safe operation no longer possible**

If it can be assumed that safe operation is no longer possible, the sampling system must be taken out of operation and secured against being started up again.

It can be assumed that safe operation is no longer possible:

- if the sampling system is visibly seriously damaged,
- if the sampling system is no longer operational,
- after prolonged storage under adverse conditions,
- after severe transport stress.

## Checking general condition



Observe all safety instructions in the section *Safety regulations for operation* on page 136 when performing this work.

### Condition of the sampling system

When the gas sampling system is in operation, monitor the general condition of the system on a daily basis:

Module	Procedure
<b>Retractor including probe</b>	<p>Check general condition of retractor with regard to the following:</p> <ul style="list-style-type: none"> <li>▪ general damage</li> <li>▪ missing or loose covers</li> <li>▪ visible damage to electric cables</li> <li>▪ hose and pipe leaks</li> <li>▪ drive chain: <ul style="list-style-type: none"> <li>▪ chain tension</li> <li>▪ chain link wear</li> </ul> </li> <li>▪ compressed-air oiler <ul style="list-style-type: none"> <li>▪ damage</li> <li>▪ leaks</li> <li>▪ oil level</li> </ul> </li> <li>▪ gas sampling probe: <ul style="list-style-type: none"> <li>▪ signs of wear (e.g. polished metal surfaces)</li> </ul> </li> </ul>
<b>Cooling module</b>	<p>Check general condition of cooling module with regard to the following:</p> <ul style="list-style-type: none"> <li>▪ general damage</li> <li>▪ missing or loose covers</li> <li>▪ visible damage to electric cables</li> <li>▪ hose and pipe leaks</li> </ul>
<b>Control cabinet</b>	<p>Check general condition of control cabinet with regard to the following:</p> <ul style="list-style-type: none"> <li>▪ general damage</li> <li>▪ missing or loose covers</li> <li>▪ visible damage to electric cables</li> <li>▪ dripping water or other liquids</li> </ul>
<b>Compressed-air tank(optional)</b>	<p>Check general condition of compressed-air tank with regard to the following:</p> <ul style="list-style-type: none"> <li>▪ visible damage</li> </ul>

If there are any defects that impact safety, inform the responsible maintenance personnel. If cleaning is necessary, follow the instructions in *Checking the condition of the system, cleaning the system* on page 161.

### Checking the duct opening

Check the duct opening for clogging at regular intervals and clean if necessary.

**Note:** Inserting the gas sampling probe when the duct opening is clogged can lead to damage to the probe. The same applies to re-inserting the gas sampling probe after prolonged standstill of the sampling system.

**Special case:  
calcinator gas outlet**

Owing to the greater flow speeds in this process, after start-up the gas sampling probe must be checked frequently for wear at the calcinator gas outlet measuring point. If distinct signs of wear are visible after a short time, check the installation position of the gas sampling probe. Failing to observe this can lead to severe damage or total loss of the gas sampling probe.

## Cleaning gas sampling probe H



Observe all safety instructions in the section *Safety regulations for operation* on page 136 when performing this work.

### Starting the cleaning process

You can start a cleaning process as follows:

- Clean in MANUAL mode (on touchscreen on the control cabinet)
- Clean in MANUAL mode (remote control via network connection)
- Clean in AUTOMATIC mode (time-controlled)
- Clean in AUTOMATIC mode (error-controlled)

### Cleaning in MANUAL mode

In MANUAL mode you can start the cleaning process in the **Cleaning** dialog (Operation ► Probe ► Cleaning).

The following two buttons are available:

Button	Function
<b>Manual Mechanical Cleaning</b>	The plunger moves forward and backward once to clean the sample gas inlet.
<b>Start Manual Cleaning</b>	The system emits a blast of air lasting 5 seconds to clean the probe filter; the plunger is activated.

**Note:** In MANUAL mode you can also remote-control cleaning via a network connection.

### Cleaning in AUTOMATIC mode

In AUTOMATIC mode the cleaning process is a time-controlled, automatic process that runs as follows:

Phase	Description
1	Plunger moves forward and backward to clean the sample gas inlet. Measuring is not interrupted.

The following processes runs after a number of cleaning cycles, that you can set on the touchscreen:

Phase	Description
1	Air cannon activated to clean the wall tube.
2	Gas sampling probe moves out and in to scrape off any adhering material.
3	Plunger moves forward and backward to clean the sample gas inlet.
4	Air blast to clean the probe filter.

### Cleaning in the event of error message

**Note:** The following function is available only when SCK is connected to the ACX analysis system. When used with other analysis systems, a default sample gas probe pressure of "9999 hPa" is indicated in the "Diagnosis" menu.

In AUTOMATIC mode the following cleaning procedure is performed when the *Sample Gas Probe Pressure MIN* error message is displayed:

Phase	Description
1	Plunger moves forward and backward to clean the sample gas inlet.

This cleaning cycle is repeated up to three times. If this does not remedy the error, error message *Error 3x Cleaning Not Successful Probe H* is displayed and the gas sampling system switches to error mode. The probe is retracted out of the kiln. No more cleaning processes and movements take place. See *Errors* on page 213 section for further details.

### Configuring cleaning

Cleaning parameters such as the time between cleaning cycles are delivered as default settings with the gas sampling system (*Default operating parameter settings* on page 50). You can modify them in operation to suit local requirements and specific fuels (see *Optimizing operating parameters* on page 53).

## Cleaning gas sampling probe 60S



Observe all safety instructions in the section *Safety regulations for operation* on page 136 when performing this work.

### Starting the cleaning process

You can start a cleaning process as follows:

- Clean in MANUAL mode (on touchscreen on the control cabinet)
- Clean in MANUAL mode (remote control via network connection)
- Clean in AUTOMATIC mode (time-controlled)
- Clean in AUTOMATIC mode (error-controlled)

### Cleaning in MANUAL mode

In MANUAL mode you can start the cleaning process by pressing the **Manual Cleaning** button in the **Cleaning** dialog (Operation ► Probe 60 ► Cleaning). The cleaning process runs as follows:

Phase	Description
1	Two air blasts lasting 1 second each to clean the probe filter.
2	Two air blasts lasting 1 second each to clean the filter casing.
3	One air blast lasting 3 seconds to clean the probe pipe.

**Note:** In MANUAL mode you can also remote-control cleaning via a network connection.

### Cleaning in AUTOMATIC mode

In AUTOMATIC mode the cleaning process is a time-controlled, automatic process that runs as follows:

Phase	Description
1	Two air blasts lasting 1 second each to clean the probe filter.
2	Two air blasts lasting 1 second each to clean the filter casing.
3	One air blast lasting 3 seconds to clean the probe pipe.

The following processes runs after a number of cleaning cycles, that you can set on the touchscreen:

Phase	Description
1	Air cannon activated to clean the wall tube.
2	Gas sampling probe moves out and in to scrape off any adhering material.
3	Two air blasts lasting 1 second each to clean the probe filter.
4	Three air blasts lasting 1 second each to clean the filter casing.
5	Air blast lasting 3 seconds to clean the probe pipe.

### Cleaning in the event of error message

**Note:** The following function is available only when SCK is connected to the ACX analysis system. When used with other analysis systems, a default sample gas probe pressure of "9999 hPa" is indicated in the "Diagnosis" menu.



In AUTOMATIC mode the following cleaning procedure is performed when the *Sample Gas Probe Pressure MIN* error message is displayed:

<b>Phase</b>	<b>Description</b>
<b>1</b>	Two air blasts lasting 1 second each to clean the probe filter.
<b>2</b>	Two air blasts lasting 1 second each to clean the filter casing.
<b>3</b>	One air blast lasting 3 seconds to clean the probe pipe.

This cleaning cycle is repeated up to three times. If this does not remedy the error, error message *Error 3x Cleaning Not Successful Probe 60S* is displayed and the gas sampling system switches to error mode. The probe is retracted out of the kiln. No more cleaning processes and movements take place. See *Errors* on page 213 section for further details.

### **Configuring cleaning**

Cleaning parameters such as the time between cleaning cycles are delivered as default settings with the gas sampling system (*Default operating parameter settings* on page 50). You can modify them in operation to suit local requirements and specific fuels (see *Optimizing operating parameters* on page 53).

## Using the EMERGENCY-STOP switch



Observe all safety instructions in the section *Safety regulations for operation on page 136* when performing this work.

### Introduction

The EMERGENCY STOP switch is used to interrupt probe movement immediately in the event of danger to personnel. Actuating the switch disables all mechanisms serving to protect the gas sampling probe. The gas sampling probe interrupts its movement immediately and in any position.



The EMERGENCY STOP switch is used to interrupt probe movement in the event of danger to personnel. The probe is only retracted out of the rotary kiln after pressing the service switch.

### Instructions

What to do after pressing the EMERGENCY STOP switch:

Step	Procedure
1	Remove danger.
2	Make sure that <ul style="list-style-type: none"><li>the danger cannot occur again,</li><li>no-one is standing in the area of probe retractor travel.</li></ul>
3	Unlock the EMERGENCY STOP switch by turning the back ring in the direction of the arrow. 
4	Actuate service switch in control cabinet (i.e. turn to <i>ON</i> position). <b>WARNING!</b> Actuating the service switch moves the probe out of the kiln. <b>Do not stand in the area of travel of the probe or probe carriage until the probe has reached its end position and the warning lamps go out.</b> <b>Result:</b> The gas sampling probe is automatically retracted out of the kiln, the controller displays the <i>Maintenance</i> message.
5	Turn service switch back to the initial position ( <i>OFF</i> ).

Topic	Page
Maintenance plan .....	148
Equipment layout plan .....	152
Acquiring spare parts and wear parts .....	155
Safety regulations for maintenance work .....	156
Operating the service switch .....	159
Checking the condition of the system, cleaning the system .....	161
Evaluating trend displays .....	164
Checking the residual current circuit breaker .....	165
Checking protective installations .....	167
Checking for leaks .....	171
Gas sampling probe H: Removing incrustations .....	174
Gas sampling probe H: Replacing the intake filter .....	176
Gas sampling probe H: Replacing membrane pump membranes .....	179
Gas sampling probe 60S: Removing incrustations .....	182
Gas sampling probe 60S: Cleaning or replacing the outlet filter .....	184
Gas sampling probe 60S: Replacing the seal set .....	187
Probe retractor: Checking filter/pressure control combination .....	189
Probe retractor: Checking and replacing the filter muffler .....	191
Probe retractor: Checking and topping up the oiler .....	193
Probe retractor: Checking and tightening the drive chain .....	196
Probe retractor: Checking and, if necessary, adjusting the position of the probe .....	198
Probe retractor: Checking and, if necessary, adjusting the position indicator (probe end position) .....	202
Probe retractor: Checking the bellows .....	205
Cooling module: Vent the cooling-water circuit .....	206
Cooling module: Checking and topping up cooling water .....	208
Pneumatic system: Replacing the compressed-air filter .....	211

## Maintenance plan

### Introduction

This section gives an overview of maintenance work to be performed at regular intervals. The tasks described here require special training and under some circumstances involve working on control cabinet open and powered on. They must therefore only be carried out by qualified and specially trained persons.

If it can be assumed that safe operation is no longer possible, the gas sampling system must be taken out of operation and secured against being started up again unintentionally.

It can be assumed that safe operation is no longer possible:

- if the gas sampling system is visibly damaged,
- if a check reveals problems,
- if the gas sampling system no longer works,
- after prolonged storage in adverse conditions,
- after severe transport stress.



It is recommended to have the gas sampling system maintained by the ABB representative responsible for you.

### Service switch

When performing maintenance work on the gas sampling system, the service switch must be in the *ON* position with a few exceptions (for example, when checking the EMERGENCY STOP switch). Actuating the service switch automatically retracts the gas sampling probe out of the kiln, and the controller displays the *Maintenance* message. See Chapter *Operating the service switch* on page 159 for more details.

### Unintentional restart

You can secure the service switch with a padlock to prevent unintentionally restarting the gas sampling system.

**Maintenance plan**

The following tables show the maintenance intervals within which to perform maintenance work, with a link to the relevant instructions:

Maintenance task	See ...	Inspection/Maintenance interval					
		as required	daily	weekly	twice yearly	yearly	every 2 years
<p><b>General tasks</b></p> <ul style="list-style-type: none"> <li>▪ Check the system and clean if necessary</li> <li>▪ Display and evaluate trend displays</li> <li>▪ Functional test of residual current circuit breaker</li> <li>▪ Functional tests of:                             <ul style="list-style-type: none"> <li>▪ EMERGENCY STOP switch</li> <li>▪ Warning lamps</li> <li>▪ Warning buzzer</li> <li>▪ external warning horn (optional)</li> </ul> </li> </ul>	<p><i>Checking the condition of the system, cleaning the system on page 161</i></p> <p><i>Evaluating trend displays on page 164</i></p> <p><i>Checking the residual current circuit breaker on page 165</i></p> <p><i>Checking protective installations on page 167</i></p>		X				
			X		X		
						X	
							X

Maintenance task	See ...	Inspection/Maintenance interval					
		as required	daily	weekly	twice yearly	yearly	every 2 years
<p><b>Gas sampling probe H</b></p> <ul style="list-style-type: none"> <li>▪ Mechanical cleaning of probe pipe and tip</li> <li>▪ Replace intake filter</li> <li>▪ Replace membrane pump membranes</li> </ul>	<p><i>Gas sampling probe H: Removing incrustations on page 174</i></p> <p><i>Gas sampling probe H: Replacing the intake filter on page 176</i></p> <p><i>Gas sampling probe H: Replacing membrane pump membranes on page 179</i></p>	X	X				
		X				X	
					X		

Maintenance task	See ...	Inspection/Maintenance interval					
		as required	daily	weekly	twice yearly	yearly	every 2 years
<b>Gas sampling probe 60S</b> <ul style="list-style-type: none"> <li>▪ Mechanical cleaning of probe pipe and tip</li> <li>▪ Clean or replace outlet filter</li> <li>▪ Replace O-ring seals on the filter unit</li> </ul>	<i>Gas sampling probe 60S: Removing incrustations on page 182</i>	X	X				
	<i>Gas sampling probe 60S: Cleaning or replacing the outlet filter on page 184</i>	X				X	
	<i>Gas sampling probe 60S: Replacing the seal set on page 187</i>				X		

Maintenance task	See ...	Inspection/Maintenance interval					
		as required	daily	weekly	twice yearly	yearly	every 2 years
<b>Probe retractor</b> <ul style="list-style-type: none"> <li>▪ Check filter muffler</li> <li>▪ Check oil level in oiler in pneumatic box and changing the quantity of oil delivered</li> <li>▪ Check and if necessary tighten drive chain</li> <li>▪ Check and if necessary adjust the filter/pressure control combination or replace filter</li> <li>▪ Check condition of bellows</li> <li>▪ Check and, if necessary, adjust the position of the probe</li> <li>▪ Check position indicator on the retractor and, if necessary, re-align</li> </ul>	<i>Probe retractor: Checking and replacing the filter muffler on page 191</i>				X		
	<i>Probe retractor: Checking and topping up the oiler on page 193</i>				X		
	<i>Probe retractor: Checking and tightening the drive chain on page 196</i>	X		X			
	<i>Probe retractor: Checking filter/pressure control combination on page 189</i>				X		
	<i>Probe retractor: Checking the bellows on page 205</i>						X
	<i>Probe retractor: Checking and, if necessary, adjusting the position of the probe on page 198</i>				X		
	<i>Probe retractor: Checking and, if necessary, adjusting the position indicator (probe end position) on page 202</i>	X			X		

Maintenance task	See ...	Inspection/Maintenance interval					
		as required	daily	weekly	twice yearly	yearly	every 2 years
<b>Cooling module</b> <ul style="list-style-type: none"> <li>▪ Check cooling water, top up if necessary</li> <li>▪ Vent the cooling-water circuit</li> <li>▪ Check cooling-water system for leaks</li> </ul>	<i>Cooling module: Checking and topping up cooling water on page 208</i> <i>Cooling module: Venting the cooling-water circuit on page 206</i> <i>Checking for leaks on page 171</i>	X	X		X		

Maintenance task	See ...	Inspection/Maintenance interval					
		as required	daily	weekly	twice yearly	yearly	every 2 years
<b>Pneumatic system</b> <ul style="list-style-type: none"> <li>▪ Replace compressed-air filter in pneumatic box</li> <li>▪ Check compressed-air system for leaks</li> </ul>	<i>Pneumatic system: Replacing the compressed-air filter on page 211</i> <i>Checking for leaks on page 171</i>				X		

## Equipment layout plan

### Illustration

Diagram of the location of maintenance-relevant equipment on the retractor (detailed view of pneumatic box below):

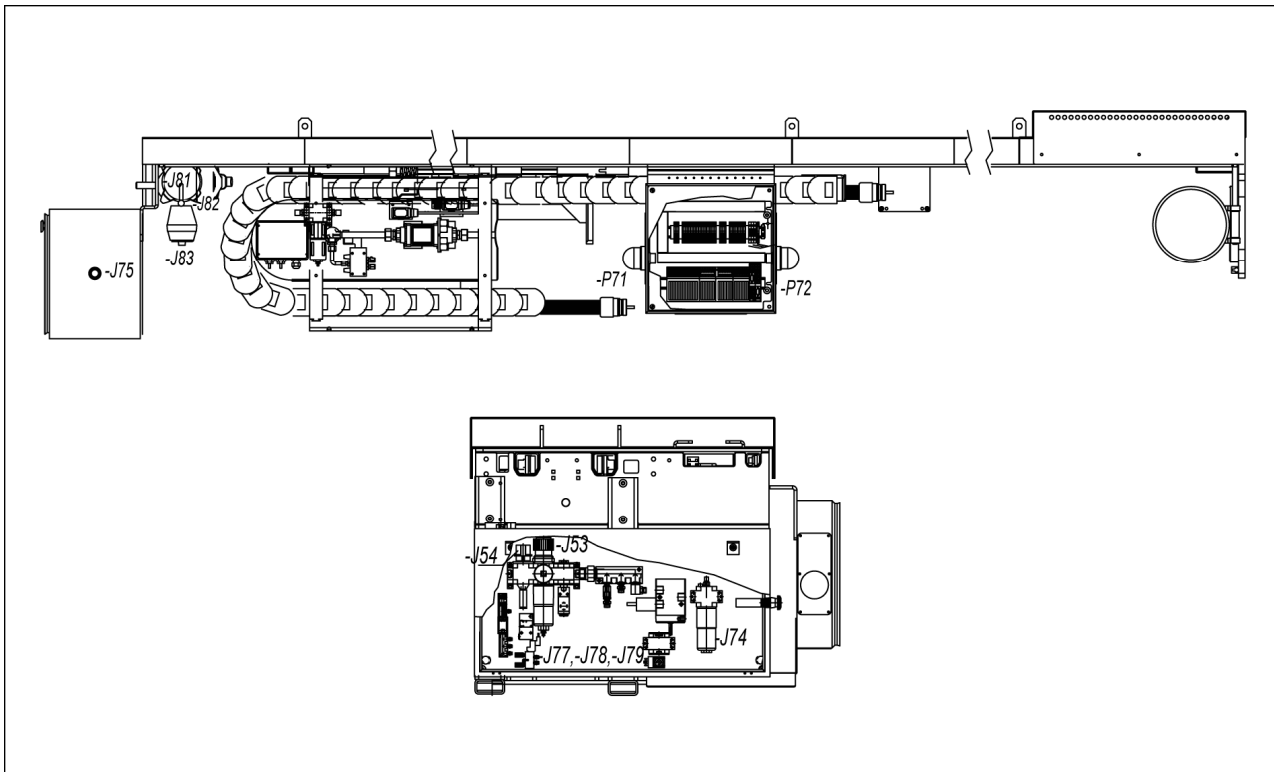

### Equipment

The following table lists the above-mentioned equipment:

Equipment ID	Designation
-J53	Filter/pressure control combination
-J54	Compressed-air gate valve
-J74	Pneumatic motor oiler
-J75	EMERGENCY-STOP switch for probe movement
-J77	Pneumatic valve "Insert probe"
-J78	Pneumatic valve "Retract probe"
-J79	Pneumatic valve "shutter"
-J81	Pneumatic motor
-J82	Gate valve
-J83	Air filter
-P71	Probe movement warning lamp
-P72	Probe movement warning lamp
<i>not illustrated</i>	Position indicators -B71, -B72, -S72



**Illustration**

Diagram of the location of maintenance-relevant equipment on the control cabinet (open left, closed right):

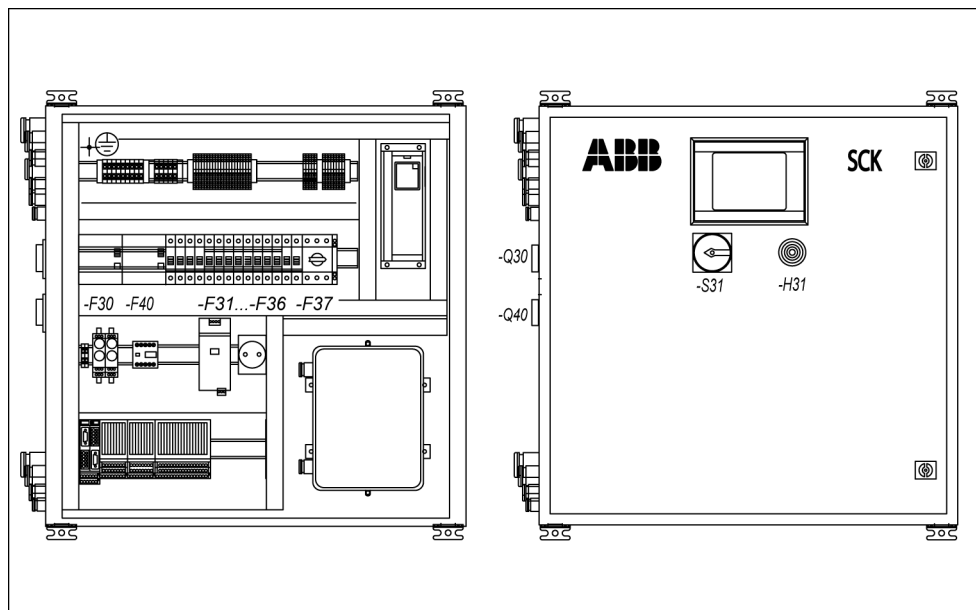

**Equipment**

The following table lists the above-mentioned equipment:

Equipment ID	Designation
-H31	Warning buzzer
-F30	Residual current circuit breaker (for main switch; optional)
-F40	Residual current circuit breaker (for UPS; optional)
-F31	Service socket circuit breaker
-F32	Power supply circuit breaker 24V
-F33	Probe heating circuit breaker
-F34	Sample gas line/connection box/230 V valves heating circuit breaker
-F35	Heat exchanger circuit breaker
-F36	Cooling-water pump circuit breaker
-F37	Cooling-water pump motor breaker
-S31	Service switch
-Q30	Main switch for normal voltage
-Q40	Main switch for UPS (optional)

**Illustration**

Diagram of location of maintenance-relevant equipment on cooling module:

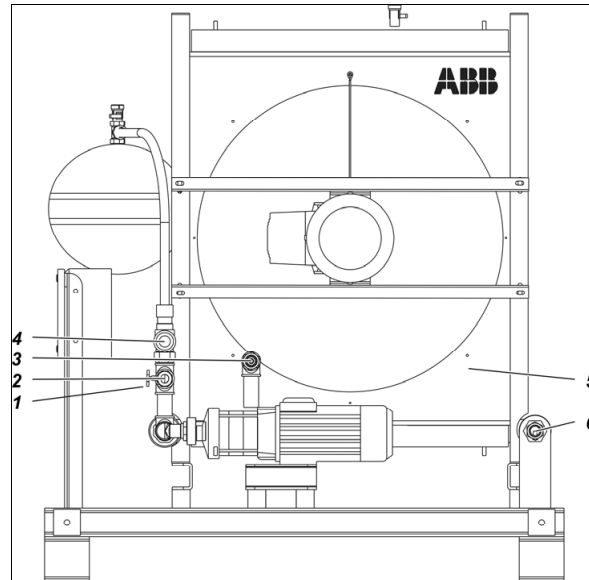

**Equipment**

The following table lists the above-mentioned equipment:

No.	Designation
1	Shut-off valve cooling water -J63
2	Cooling water inlet
3	Cooling water feed
4	Safety relief valve outlet
5	Heat exchanger -J60
6	Cooling water return

## Acquiring spare parts and wear parts

### Service

To order spare parts or to order service, please contact your local ABB service partner or:

ABB Service

Phone: +49 (0)69 7930 4706

Fax: +49 (0)69 7930 4707

Email: [service-analytical@de.abb.com](mailto:service-analytical@de.abb.com)

# Safety regulations for maintenance work

## Introduction

Maintenance personnel must observe the following safety instructions when performing maintenance work.

## Mechanical, thermal and material dangers

### **WARNING**

**Risk of injury in the area of the gas sampling system due to moving or falling parts, hot surfaces, hot cooling water, anti-freeze, compressed air, lubricating oil**

Wear general personal protective equipment:

- ▶ Closed overalls with long trousers and long sleeves
- ▶ Safety shoes
- ▶ Safety gloves suitable for mechanical work
- ▶ Safety glasses
- ▶ Protective helmet
- ▶ If necessary, additional protective equipment if prescribed by the operator.

## Heavy transport units

### **WARNING**

**Danger of crushing when lifting or lowering the transport unit**

- ▶ Only appropriately trained personnel may transport the transport units and only with the aid of the recommended transport equipment.
- ▶ Do not stand under suspended loads.
- ▶ Follow the transport instructions in these operating instructions carefully.

## Gas sampling probe movements

### **WARNING**

**Risk of crushing around the retractor due to gas sampling probe movements**

- ▶ Before commencing any work on the gas sampling system, turn the service switch to "ON" and secure the service switch against unauthorized switching (with a padlock).
- ▶ Additionally press the EMERGENCY-STOP switch before working on the retractor or probe.
- ▶ Do not enter the danger area around the retractor until it is at standstill and the warning lamps and buzzer are off.
- ▶ Never stand in the danger area around the retractor when the protective installation is closed.
- ▶ When the warning lamps light up or the warning buzzer buzzes, leave the danger area around the probe retractor immediately as the probe is about to move at any moment.
- ▶ Press the EMERGENCY-STOP switch immediately if anyone is still in the danger area around the retractor after the warning lamps light up or the warning buzzer buzzes.

## Current-carrying components

### **DANGER**

**Danger of electric shock when working on electric components**

- ▶ Only specialized electrical personnel may work on the electrical system.
- ▶ Disconnect the gas sampling system from the power supply before working on the electrical components.
- ▶ Observe national regulations pertaining to electrical equipment.

## Hot surfaces

### **WARNING**

#### **Danger of burning due to hot surfaces during and after operation of the gas sampling system**

- ▶ Do not touch the gas sampling system during and after operation.
- ▶ Do not touch the gas sampling system until it has cooled down to 50 °C. Specifically, do not touch
  - the cooling module,
  - the heated sample gas line,
  - the connection box for the heated sample gas line on the retractor,
  - the heated sampling filter,
  - the entire gas sampling probe,
  - the metal structure of the retractor,
  - the shutter of the duct opening.
- ▶ If it is unavoidable to touch hot components, wear a face mask against heat, heat-proof gloves and protective welder's clothing.

## Falling or spalling hot material

### **WARNING**

#### **Danger of burning due to material falling or spalling off the retracted probe**

- ▶ Never enter the danger area around the retractor during operation.
- ▶ Do not approach the retracted probe until it has cooled down.
- ▶ If it is unavoidable to approach the hot probe, wear a face mask against heat, heat-proof gloves and protective welder's clothing.

## Harmful gases, jet flames

### **WARNING**

#### **Danger due to harmful gases from the rotary kiln and jet flames in the area of the shutter, particularly while the gas sampling probe is moving in and out**

- ▶ Ensure adequate ventilation of the work place.
- ▶ Only enter the danger area around the retractor when the shutter is closed.
- ▶ If work is unavoidable in the area of the duct opening, lock the shutter before commencing work and wear respiratory protection.

## Hot cooling water

### **WARNING**

#### **Risk of scalding due to hot cooling water when working on the cooling-water circuit, above all on drain valves and screw connections**

- ▶ Do not perform work on the cooling water circuit until the gas sampling system has cooled down.

## Harmful anti-freeze

### **CAUTION**

#### **Danger of injury to skin and eyes in the event of contact with cooling water or anti-freeze**

- ▶ Avoid contact with the cooling water and the anti-freeze.
- ▶ Wash any cooling water and anti-freeze off the skin immediately with water and soap.
- ▶ If cooling water or anti-freeze gets in the eyes despite protective glasses, rinse them thoroughly under running water, holding the eyelids open.
- ▶ Observe instructions in the anti-freeze manufacturer's safety data sheet.

**Harmful  
lubricating oil**

**⚠ CAUTION**

**Danger due to skin and eye injuries in the event of contact with lubricating oil from the pneumatic box of, from the filter muffler or from inside the pneumatic motor**

- ▶ Avoid contact with lubricating oil.
- ▶ Wash any lubricating oil off the skin immediately with water and soap.
- ▶ If any lubricating oil gets in the eyes despite protective glasses, rinse them thoroughly under running water, holding the eyelids open.
- ▶ Observe instructions in the lubricating oil manufacturer's safety data sheet.

**Harmful  
dusts**

**⚠ CAUTION**

**Danger due to harmful dusts when cleaning the gas sampling system**

- ▶ Wear a dust mask when cleaning.
- ▶ Wash any dust off the skin immediately with water and soap.

**Slippery floor**

**⚠ CAUTION**

**Risk of falling on slippery floor due to escaped or spilled cooling water and lubricating oil or dirt**

- ▶ Always keep the floor around the gas sampling system clean and dry.

## Operating the service switch

### Meaning

The service switch puts the system into maintenance mode. If work described in the following maintenance instructions must be performed in maintenance mode, proceed as follows.

### Safety measures

#### **▲WARNING**

Always take the following safety measures when performing this work:

- ▶ Wear the general protective equipment.
- ▶ Before commencing any work on the gas sampling system, turn the service switch to *ON* and secure the service switch against unauthorized switching (with a padlock).
- ▶ Additionally press the EMERGENCY-STOP switch before working on the retractor or probe.
- ▶ Do not enter the danger area around the retractor until it is at standstill and the warning lamps and buzzer are off.
- ▶ Never stand in the danger area around the retractor when the protective installation is closed.
- ▶ When the warning lamps light up or the warning buzzer buzzes, leave the danger area around the probe retractor immediately as the probe is about to move at any moment.
- ▶ Press the EMERGENCY-STOP switch immediately if anyone is still in the danger area around the retractor after the warning lamps light up or the warning buzzer buzzes.

Explanation of safety measures: *Safety regulations for maintenance work on page 156.*

### Requirement

The service switch is in the *OFF* position.

**Instructions**

How to put the system into maintenance mode:

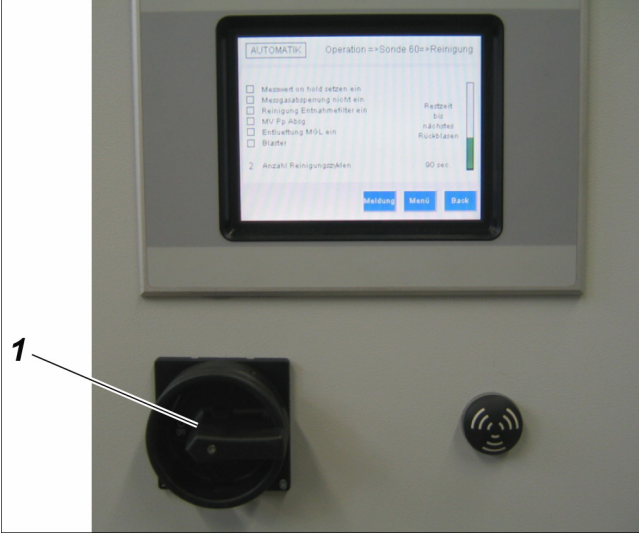
Step	Procedure
1	Make sure that no-one is standing in the area of probe retractor travel.
2	<p>On the control cabinet: Turn service switch -S31 (1) clockwise to the ON position.</p> <p><b>WARNING!</b> Actuating the service switch moves the probe out of the kiln. <b>Do not stand in the area of travel of the probe or probe carriage until the probe has reached its end position and the warning lamps go out.</b></p>  <p><b>Result:</b> The gas sampling probe is automatically retracted out of the kiln; the controller displays the <i>Maintenance</i> message.</p>
3	Secure the service switch against unauthorized actuation.
4	When working on the retractor and gas sampling probe, additionally actuate the EMERGENCY-STOP switch for reasons of safety.
5	Perform maintenance tasks.
6	Leave danger area around the retractor and close the protective installation.
7	Turn service switch -S31 counter-clockwise to the OFF position.
8	<p>Re-insert the probe using the controller.</p> <p><b>Path:</b> Operation ► Probe ► Probe Action ► Insert</p> <p><b>WARNING!</b> The probe moves into the kiln. <b>Do not stand in the area of travel of the probe or probe carriage.</b></p>



## Checking the condition of the system, cleaning the system

### Meaning

Check the condition of the gas sampling system at regular intervals; in the event of safety-relevant defects, inform the responsible maintenance personnel. If you observe any unusual noises, follow the recommendations in *Errors* on page 213. If necessary, submit the gas sampling system to rough cleaning. Special attention should be given to the following:

- dust under covers and in connection boxes
- excessive dirt on the surface of the modules
- excessive soiling of the runner in the probe retractor
- heat exchanger cooling fins

### Maintenance interval

- daily

### Safety measures

#### **WARNING**

Always take the following safety measures when performing the work described below:

- ▶ Wear the general protective equipment.
- ▶ Turn the service switch to *ON* and secure the service switch against unauthorized switching (with a padlock).
- ▶ Additionally press the EMERGENCY STOP switch.
- ▶ Do not enter the danger area around the retractor until it is at standstill and the warning lamps and buzzer are off and the shutter is closed.
- ▶ Do not touch the gas sampling system until it has cooled down to 50 °C.
- ▶ Do not approach the retracted probe until it has cooled down.
- ▶ Always keep the floor around the gas sampling system clean and dry.

When performing any cleaning work:

- ▶ Wear a dust mask when cleaning.
- ▶ Wash any dust off the skin immediately with water and soap.
- ▶ Ensure adequate ventilation of the work place.

Checking and cleaning the probe retractor:

- ▶ If work is unavoidable in the area of the duct opening, lock the shutter before commencing work and wear respiratory protection.
- ▶ Avoid contact with lubricating oil.
- ▶ Wash any lubricating oil off the skin immediately with water and soap.
- ▶ If any lubricating oil gets in the eyes despite protective glasses, rinse them thoroughly under running water, holding the eyelids open.
- ▶ Observe instructions in the lubricating oil manufacturer's safety data sheet.

Checking the duct opening:

- ▶ Preferably check and clean the duct opening when the rotary kiln is out of operation. If you clean the duct opening when the rotary kiln is in operation.
  - Wear a face mask against heat, heat-proof gloves and protective welder's clothing and respiratory protection against toxic gases.
  - Keep the time in which the feedthrough opening is open as short as possible.

Checking and cleaning the cooling module:

- ▶ Do not perform work on the cooling water circuit until the gas sampling system has cooled down.
- ▶ Avoid contact with the cooling water and the anti-freeze.

- ▶ Wash any cooling water and anti-freeze off the skin immediately with water and soap.
- ▶ If cooling water or anti-freeze gets in the eyes despite protective glasses, rinse them thoroughly under running water, holding the eyelids open.
- ▶ Observe instructions in the anti-freeze manufacturer's safety data sheet.

Explanation of safety measures: *Safety regulations for maintenance work on page 156.*

## Requirements

The following conditions must be met:

- The service switch is in the *ON* position, the gas sampling probe is completely retracted from the kiln (see *Operating the service switch* on page 159).
- The service switch is secured against unauthorized actuation.
- The gas sampling system has cooled down.
- The EMERGENCY STOP switch is pressed.

## Checking and cleaning the control cabinet:

Perform the following steps for the control cabinet:

Step	Procedure
1	Check general condition of control cabinet with regard to the following: <ul style="list-style-type: none"> <li>▪ general damage</li> <li>▪ missing or loose covers</li> <li>▪ visible damage to connection cables</li> </ul>
2	Check control cabinet for dripping water or other liquids.
3	In the event of excessive soiling of the surface of the control cabinet, clean with a soft brush or compressed-air.
4	Clean touchscreen, particularly edge areas, with compressed-air and/or moist cloth (if you use cleaning agents, you can request a resistance table from ABB Service).

## Checking and cleaning the probe retractor

Perform the following steps for the probe retractor:

Step	Procedure
1	Check general condition of retractor with regard to the following: <ul style="list-style-type: none"> <li>▪ general damage</li> <li>▪ missing or loose covers</li> <li>▪ visible damage to electric cables</li> </ul>
2	Check hoses and pipes for leaks
3	In the event of excessive soiling of the surface of the retractor, clean with a soft brush or compressed-air; treat rollers in the same way.
4	Check condition of drive chain with regard to the following: <ul style="list-style-type: none"> <li>▪ chain tension</li> <li>▪ chain link wear</li> </ul>
5	In pneumatic box: Check compressed-air oiler for the following: <ul style="list-style-type: none"> <li>▪ damage</li> <li>▪ leaks</li> <li>▪ oil level</li> </ul>

Step	Procedure
6	Check compressed-air tank (if present) for visible damage.
7	Check probe pipe for signs of wear, e.g. polished metal surfaces. This applies particularly after start-up, after changing the alignment of the probe, etc. The calcinator outlet measuring point is particularly affected.  If you observe signs of wear, you must reposition the gas sampling probe in the process gas flow; if you have any questions regarding repositioning the probe, contact ABB Service.

### Checking the duct opening

Check the wall tube for clogging and deposits at regular intervals and clean if necessary.

**Note:** Inserting the gas sampling probe when the wall tube is clogged can lead to damage to the probe. The same applies to re-inserting the gas sampling probe after prolonged standstill of the gas sampling system.

### Checking and cleaning the cooling module

Perform the following steps for the cooling module:

Step	Procedure
1	Check general condition of cooling module with regard to the following: <ul style="list-style-type: none"> <li>▪ general damage</li> <li>▪ missing or loose covers</li> <li>▪ visible damage to connection cables</li> </ul>
2	Check hoses and pipes for leaks
3	In the event of excessive soiling of the surface of the cooling module, or after one week at the latest, clean with a soft brush or compressed-air.
4	Clean motor casing with compressed air.
5	Clean cooling fins with dry compressed air (accessible at the back of the heat exchanger).
6	Check cooling module environment for any materials that can fly around easily.

## Evaluating trend displays

**Meaning** Irregularities of cooling-water pressure, cooling-water flow rate and cooling-water temperature may indicate various errors. Common reasons for an increase or drop in measured values may be, for example, a clogged filter, incrustations on the gas sampling probe, inadequate cooling of the heat exchanger or inadequate delivery rate of the cooling-water pump.

**Requirements** Displaying trend displays requires an access level 2 password.

**Instructions** Perform the following steps to evaluate trend displays:

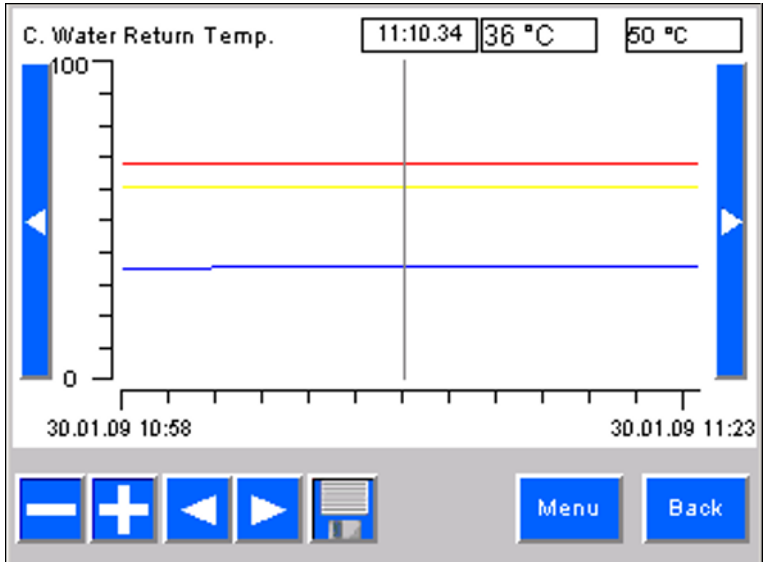
Step	Procedure
1	Open the Trends submenu. <b>Path:</b> Diagnosis ► Trends
2	Select one of the available parameters: <ul style="list-style-type: none"> <li>▪ "Sample Gas Pressure"</li> <li>▪ "Cooling Water Pressure"</li> <li>▪ "Cooling Water Flow Rate"</li> <li>▪ "Cooling Water Flow Temp."</li> <li>▪ "Cooling Water Return Temp."</li> </ul>
3	<p>A typical trend screen is displayed:</p>  <p>The measured value is blue, alarm thresholds are also highlighted with a special color:</p> <ul style="list-style-type: none"> <li>▪ Pre-alarm (maintenance required): yellow</li> <li>▪ Main alarm (error): red</li> </ul> <p>The reading rule indicates the measured value at the specific time. A zoom function allows you to zoom in on details. For further details refer to section <i>Description of control system</i> on page 37.</p>

## Checking the residual current circuit breaker

### Meaning

Residual current circuit breakers disconnect the monitored circuit from the remaining grid in the event of a certain differential electric current. Test the residual current circuit breaker at regular intervals in order to simulate this error.

### Maintenance interval

- twice yearly

### Current-carrying components



**Danger of electric shock when control cabinet is open, open connection or terminal boxes**

- ▶ Only specialized electrical personnel may work on the electrical system.
- ▶ Observe national regulations pertaining to electrical equipment.

### Illustration

The following diagram shows the location of the residual current circuit breaker in the control cabinet. Integration of residual current circuit breakers is variable in the gas sampling system. No residual current circuit breaker is integrated in the standard model, the "FI" option (-F30) has a 4-pole residual circuit breaker for the normal grid, the "FI" + "UPS" option (-F40) has two residual circuit breakers (4-pole and 2-pole).

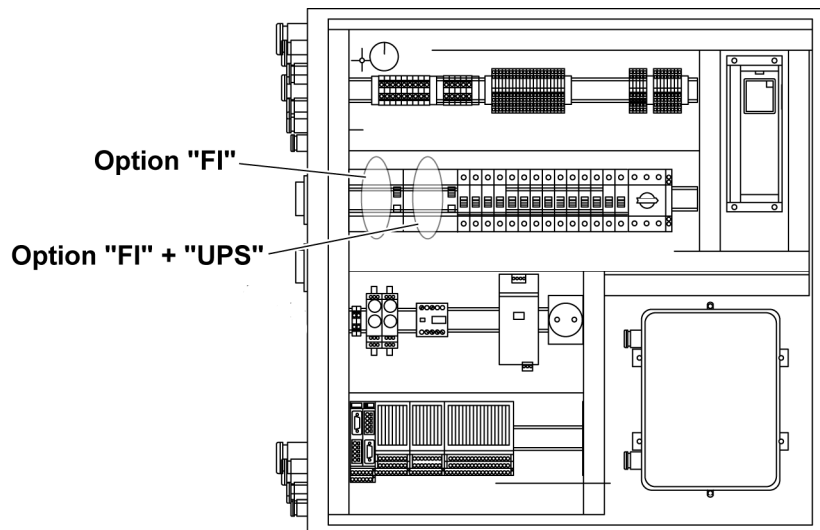

### Tools required

- Control cabinet key to open the control cabinet

### Requirements

The service switch is in the *ON* position; the gas sampling probe is completely retracted from the kiln (see *Operating the service switch* on page 159).

**Instructions**

Proceed as follows to check the residual current circuit breaker:

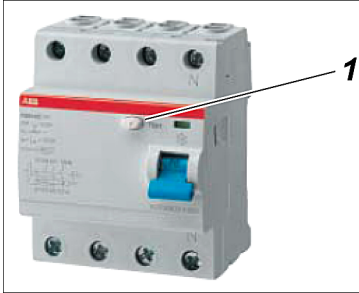
Step	Procedure						
1	Open the control cabinet.						
2	<p>Press the Test button <b>(1)</b> on the residual current circuit breaker -F30 to start the self-test (in diagram: 4-pole residual current circuit breaker for normal grid).</p> 						
3	<p>Result of function test:</p> <table border="1" data-bbox="606 734 1356 958"> <thead> <tr> <th data-bbox="606 734 885 779">If ...</th> <th data-bbox="885 734 1356 779">, then ...</th> </tr> </thead> <tbody> <tr> <td data-bbox="606 779 885 857">the residual current circuit breaker trips</td> <td data-bbox="885 779 1356 857">the residual current circuit breaker is working as intended.</td> </tr> <tr> <td data-bbox="606 857 885 958">the residual current circuit breaker does <i>not</i> trip</td> <td data-bbox="885 857 1356 958">shut down the sampling system, secure against start-up, and have it repaired by trained, expert personnel.</td> </tr> </tbody> </table>	If ...	, then ...	the residual current circuit breaker trips	the residual current circuit breaker is working as intended.	the residual current circuit breaker does <i>not</i> trip	shut down the sampling system, secure against start-up, and have it repaired by trained, expert personnel.
If ...	, then ...						
the residual current circuit breaker trips	the residual current circuit breaker is working as intended.						
the residual current circuit breaker does <i>not</i> trip	shut down the sampling system, secure against start-up, and have it repaired by trained, expert personnel.						
4	Perform steps 1 through 3 with residual current circuit breaker for UPS -F40 (if present).						
5	Switch residual current circuit breaker -F30/-F40 back on.						
6	Lock the control cabinet.						

## Checking protective installations

### Maintenance interval

- at least once a year

EMERGENCY STOP switch: The EMERGENCY STOP switch -J75 should be checked after shutting down the kiln if possible, as the test procedure disables all monitoring mechanisms. If it is necessary to check during operation, the retracting probe retractor must be max. one meter from the rear end position when you actuate the EMERGENCY STOP switch -J75 in order to prevent uncontrolled heat-up of the probe tip if an error occurs at the same time.



Observe company regulations with regard to maintenance intervals.

### Safety measures

#### **WARNING**

Always take the following safety measures when performing this work:

- ▶ Wear the general protective equipment.
- ▶ Press the EMERGENCY STOP switch immediately if anyone is still in the danger area around the retractor after the warning lamps light up or the warning buzzer buzzes.

Explanation of safety measures: *Safety regulations for maintenance work on page 156.*

### Requirements

The following conditions must be met:

- System is in operation.
- Gas sampling probe is inserted into the kiln.
- Service switch is in the *OFF* position.

**Instructions:  
checking the  
EMERGENCY STOP  
switch**

Proceed as follows to check the EMERGENCY STOP switch -J75 (note: two people should perform this procedure):

Step	Procedure
1	Switch system to manual mode on the touchscreen (if this has not already been done). <b>Path:</b> Operation ► Automatic on / off
2	Retract gas sampling probe out of the kiln. <b>Path:</b> Operation ► Probe ► Probe Action ► Retract <b>WARNING!</b> Actuating the service switch moves the probe to its end position. <b>Do not stand in the area of travel of the probe or probe carriage until the probe has reached its end position.</b>
3	When the probe is one meter from the rear end position: Press EMERGENCY STOP switch -J75. <b>Target requirement:</b> The probe retractor must interrupt movement immediately.
4	Unlock EMERGENCY STOP switch -J75 by turning the back ring in the direction of the arrow. 
5	Turn service switch -S31 on the control cabinet to the <i>ON</i> position. <b>WARNING!</b> Actuating the service switch moves the probe to its rear end position. <b>Do not stand in the area of travel of the probe or probe carriage until the probe has reached its end position.</b> <b>Result:</b> The gas sampling probe is retracted to its rear end position, the controller displays the <i>Maintenance</i> message.
6	Turn service switch -S31 back to the initial position ( <i>OFF</i> ).
7	In the event of irregularities, shut down the sampling system, secure against start-up (e.g. with a padlock), and have it repaired by trained, expert personnel.
8	If a second EMERGENCY STOP switch is present, perform these instructions analogously for this switch.
9	Turn service switch back to <i>OFF</i> position and insert gas sampling probe again using the controller. <b>WARNING!</b> Gas sampling probe moves into the kiln. <b>Do not stand in the area of travel of the gas sampling probe or probe carriage until the probe is completely inserted into the kiln and the warning lamps go out.</b>



**Instructions:  
checking warning  
lamps**

Perform the following steps to check warning lamps *-P71 and -P72*:

Step	Procedure
1	Switch system to manual mode on the touchscreen (if this has not already been done). <b>Path:</b> Operation ► Automatic on / off
2	Retract gas sampling probe out of the kiln. <b>Path:</b> Operation ► Probe ► Probe Action ► Retract <b>WARNING!</b> The probe is retracted. <b>Do not stand in the area of travel of the probe or probe carriage until the probe has reached its end position.</b> <b>Target requirement:</b> Warning lamps <i>-P71 and -P72</i> on the retractor light up immediately.
3	In the event of irregularities, shut down the sampling system, secure against start-up (e.g. with a padlock), and have it repaired by trained, expert personnel.  If they are working as intended: Turn service switch back to <i>OFF</i> position and insert gas sampling probe again using the controller. <b>WARNING!</b> Gas sampling probe moves into the kiln. <b>Do not stand in the area of travel of the gas sampling probe or probe carriage until the probe is completely inserted into the kiln and the warning lamps go out.</b>

**Instructions:  
checking warning  
buzzers**

Perform the following steps to check the warning buzzer *-H31*:

Step	Procedure
1	Switch system to manual mode on the touchscreen (if this has not already been done). <b>Path:</b> Operation ► Automatic on / off
2	Retract gas sampling probe out of the kiln. <b>Path:</b> Operation ► Probe ► Probe Action ► Retract <b>WARNING!</b> The probe is retracted. <b>Do not stand in the area of travel of the probe or probe carriage until the probe has reached its end position.</b> <b>Target requirement:</b> Warning buzzer <i>-H31</i> on the control cabinet buzzes.
3	In the event of irregularities, shut down the sampling system, secure against start-up (e.g. with a padlock), and have it repaired by trained, expert personnel.  If they are working as intended: Turn service switch back to <i>OFF</i> position and insert gas sampling probe again using the controller. <b>WARNING!</b> Gas sampling probe moves into the kiln. <b>Do not stand in the area of travel of the gas sampling probe or probe carriage until the probe is completely inserted into the kiln and the warning lamps go out.</b>

**Instructions:  
checking the  
additional warning  
horn**

Perform the following steps to check the additional warning horn (provided by customer):

<b>Step</b>	<b>Procedure</b>
<b>1</b>	Switch system to manual mode on the touchscreen (if this has not already been done). <b>Path:</b> Operation ► Automatic on / off
<b>2</b>	Retract gas sampling probe out of the kiln. <b>Path:</b> Operation ► Probe ► Probe Action ► Retract <b>Target requirement:</b> The warning horn goes off.
<b>3</b>	In the event of irregularities, shut down the sampling system, secure against start-up (e.g. with a padlock), and have it repaired by trained, expert personnel.  If they are working as intended: Turn service switch back to <i>OFF</i> position and insert gas sampling probe again using the controller. <b>WARNING!</b> Gas sampling probe moves into the kiln. <b>Do not stand in the area of travel of the gas sampling probe or probe carriage until the probe is completely inserted into the kiln and the warning lamps go out.</b>

## Checking for leaks

**Meaning** Sample gas paths, the compressed-air system and cooling-water circuit must be checked for leaks on a regular basis.

**Maintenance interval**

- twice yearly
- as required in the following cases:
  - Sample gas paths: additionally after opening sample gas lines inside the connected analyzer cabinet
  - Cooling-water circuit: additionally when pressure in the cooling-water circuit drops frequently
  - Compressed-air system: additionally when pressure drops in the compressed-air system without any cleaning process or probe retractor movement taking place.

### Safety measures

#### **WARNING**

Always take the following safety measures when performing this work:

- ▶ Wear the general protective equipment.
- ▶ Turn the service switch to *ON* and secure the service switch against unauthorized switching (with a padlock).
- ▶ Additionally press the EMERGENCY STOP switch.
- ▶ Do not enter the danger area around the retractor until it is at standstill and the warning lamps and buzzer are off and the shutter is closed.
- ▶ Do not perform the work until the gas sampling system has cooled down.
- ▶ Avoid contact with the cooling water and the anti-freeze.
- ▶ Wash any cooling water and anti-freeze off the skin immediately with water and soap.
- ▶ If cooling water or anti-freeze gets in the eyes despite protective glasses, rinse them thoroughly under running water, holding the eyelids open.
- ▶ Observe instructions in the anti-freeze manufacturer's safety data sheet.
- ▶ Avoid contact with lubricating oil.
- ▶ Wash any lubricating oil off the skin immediately with water and soap.
- ▶ If any lubricating oil gets in the eyes despite protective glasses, rinse them thoroughly under running water, holding the eyelids open.
- ▶ Observe instructions in the lubricating oil manufacturer's safety data sheet.
- ▶ Always keep the floor around the gas sampling system clean and dry.

Explanation of safety measures: *Safety regulations for maintenance work on page 156.*

**Required tools** The following tools are required:

- For checking the compressed-air system and cooling-water circuit for leaks: leak detection spray

### Instructions: checking sample gas paths

How to check the sample gas paths up to the sample gas pump:

Step	Procedure
1	Switch service switch to <i>ON</i> position (see <i>Operating the service switch</i> on page 159), press EMERGENCY STOP switch and allow gas sampling system to cool down. <i>WARNING!</i> Risk of burning in the event of contact with components that are still hot. <i>Do not touch components until they have cooled down to below 50 °C.</i>
2	Detach probe-side connection of sample gas path and seal.
3	Detach analyzer -side connection and fit a tee with shut-off valve.
4	Connect a U-tube manometer half filled with water to the open outlet of the tee.
5	Blow nitrogen or air through the shut-off valve to a positive pressure of 100 hPa (= 1000 mm water column).
6	Close the shut-off valve. Pressure should not change noticeably within one minute (pressure drop < 1 hPa). A greater pressure drop indicates a leak.
7	After fixing any leaks, refit the sample gas lines.
8	Turn service switch back to <i>OFF</i> position and insert gas sampling probe again using the controller. <i>WARNING!</i> Gas sampling probe moves into the kiln. <i>Do not stand in the area of travel of the gas sampling probe or probe carriage until the probe is completely inserted into the kiln and the warning lamps go out.</i>

**Instructions:  
checking the  
compressed-air  
system**

How to check the compressed-air system for leaks:

Step	Procedure
1	Switch service switch to <i>ON</i> position (see <i>Operating the service switch</i> on page 159), press EMERGENCY STOP switch and allow gas sampling system to cool down. <i>WARNING!</i> Risk of burning in the event of contact with components that are still hot. <i>Do not touch components until they have cooled down to below 50 °C.</i>
2	Spray leak detection spray on: <ul style="list-style-type: none"> <li>▪ Screw connections and connectors</li> <li>▪ Compressed-air tubes</li> </ul> Also listen for audible blowing-off sounds.
3	If you locate a leak: replace component and ensure adequate sealing.
4	Turn service switch back to <i>OFF</i> position and insert probe again using the controller. <i>WARNING!</i> Probe moves into the kiln. <i>Do not stand in the area of travel of the probe or probe carriage until the probe is completely inserted into the kiln and the warning lamps go out.</i>

**Instructions:  
checking the cooling-  
water circuit**

How to check the cooling-water circuit for leaks:

Step	Procedure						
1	<p>Switch service switch to <i>ON</i> position (see <i>Operating the service switch</i> on page 159), press EMERGENCY STOP switch and allow gas sampling system to cool down.</p> <p><b>WARNING!</b> Risk of burning in the event of contact with components that are still hot. <i>Do not touch components until they have cooled down to below 50 °C.</i></p>						
2	<p>Switch off the cooling-water pump -M51 at the motor breaker -F37 (1).</p> <div data-bbox="606 521 1157 929" data-label="Image"> </div> <p><i>Note:</i> You can also switch off the cooling-water pump at circuit breaker -F36 (2).</p>						
3	<p>Sight-check the cooling-water circuit.</p> <table border="1" data-bbox="614 1093 1361 1317"> <thead> <tr> <th data-bbox="614 1093 997 1137"><i>If ...</i></th> <th data-bbox="997 1093 1361 1137"><i>then ...</i></th> </tr> </thead> <tbody> <tr> <td data-bbox="614 1137 997 1209">you locate a leak,</td> <td data-bbox="997 1137 1361 1209">replace component and ensure adequate sealing.</td> </tr> <tr> <td data-bbox="614 1209 997 1317">no leak was found but pressure continues to drop in operation,</td> <td data-bbox="997 1209 1361 1317">follow steps 3 - 6.</td> </tr> </tbody> </table>	<i>If ...</i>	<i>then ...</i>	you locate a leak,	replace component and ensure adequate sealing.	no leak was found but pressure continues to drop in operation,	follow steps 3 - 6.
<i>If ...</i>	<i>then ...</i>						
you locate a leak,	replace component and ensure adequate sealing.						
no leak was found but pressure continues to drop in operation,	follow steps 3 - 6.						
4	Drain the cooling-water circuit.						
5	Fill cooling-water circuit with compressed air, max. 3 bar (3000 hPa).						
6	Spray cooling-water circuit with leak detection spray.						
7	If you locate a leak: replace component and ensure adequate sealing.						
8	Fill up cooling water again and vent (see <i>Preparing the cooling-water circuit</i> on page 114).						
9	Switch the cooling-water pump -M51 on again at motor breaker -F37 or circuit breaker -F36.						
10	<p>Turn service switch back to <i>OFF</i> position and insert probe again using the controller.</p> <p><b>WARNING!</b> Probe moves into the kiln. <i>Do not stand in the area of travel of the probe or probe carriage until the probe is completely inserted into the kiln and the warning lamps go out.</i></p>						

## Gas sampling probe H: Removing incrustations

**Maintenance interval**   ▪ daily (or as required)

### Safety measures

**▲WARNING**

Always take the following safety measures when performing this work:

- ▶ Wear a face mask against heat, heat-proof gloves and protective welder's clothing.
- ▶ Turn the service switch to *ON* and secure the service switch against unauthorized switching (with a padlock).
- ▶ Additionally press the EMERGENCY STOP switch.
- ▶ Do not enter the danger area around the retractor until it is at standstill and the warning lamps and buzzer are off and the shutter is closed.
- ▶ Do not perform the work until the gas sampling system has cooled down.
- ▶ Lock the shutter when you start the work, unlock the shutter after finishing the work.
- ▶ Always keep the floor around the gas sampling system clean and dry.

Explanation of safety measures: *Safety regulations for maintenance work on page 156.*

### Tools required

- Chisel
- Hammer

## Mechanical probe tip cleaning

Proceed as follows:

Step	Procedure
1	Switch service switch to <i>ON</i> position (see <i>Operating the service switch</i> on page 159), press EMERGENCY STOP switch and allow gas sampling system to cool down. <b>WARNING!</b> Risk of burning in the event of contact with the hot probe. <b>Do not touch the probe until it has cooled down to below 50 °C.</b>
2	Manually lock the shutter.
3	Mechanical cleaning: Remove incrustations on the probe tip by hitting them with a chisel. The direction of impact must be parallel to the longitudinal axis of the probe in order to prevent massive damage to the probe. The size of the tool must suit the sampling aperture in order to prevent massive damage. Avoid direct impacts on the cleaning plunger in order to prevent damage to the inside filter element. <b>Note:</b> The probe must only be cleaned mechanically. Do not use chemicals (acids, lyes, etc.) for cleaning.
4	Manually unlock the shutter.
5	In controller: insert the probe. <b>Path:</b> Operation ► Probe ► Probe Action ► Insert <b>WARNING!</b> The probe moves into the kiln. <b>Do not stand in the area of travel of the probe or probe carriage.</b>
6	In controller: launch compressed-air cleaning. <b>Path:</b> Operation ► Probe ► Cleaning ► Manual Mechanical Cleaning
7	In controller: retract the probe. <b>Path:</b> Operation ► Probe ► Probe Action ► Retract <b>WARNING!</b> The probe moves out of the kiln. <b>Do not stand in the area of travel of the probe or probe carriage.</b>
8	Check sampling aperture again, repeat mechanical cleaning if necessary.
9	Turn service switch to <i>OFF</i> position.
10	In controller: insert the probe again. <b>Path:</b> Operation ► Probe ► Probe Action ► Insert <b>WARNING!</b> The probe moves into the kiln. <b>Do not stand in the area of travel of the probe or probe carriage.</b>
11	In controller: wait for heat-up time until the following error messages disappear: "C. Water Return Temp. MIN" <b>Path:</b> Diagnosis ► Message
12	In controller: switch gas sampling probe to AUTOMATIC mode: Operation ► Automatic on / off

## Gas sampling probe H: Replacing the intake filter

**Maintenance interval**   ▪ once a year or as required

### Safety measures

**▲WARNING**

Always take the following safety measures when performing this work:

- ▶ Wear a face mask against heat, heat-proof gloves and protective welder's clothing.
- ▶ Turn the service switch to *ON* and secure the service switch against unauthorized switching (with a padlock).
- ▶ Additionally press the EMERGENCY STOP switch.
- ▶ Do not enter the danger area around the retractor until it is at standstill and the warning lamps and buzzer are off and the flap valve is closed.
- ▶ Lock the shutter when working on the plunger, unlock the shutter after replacing the filter.
- ▶ Do not perform the work until the gas sampling system has cooled down.

Explanation of safety measures: *Safety regulations for maintenance work on page 156.*

**Tools required**   ▪ Wrench (SW32)

**Requirements**   The following conditions must be met:

- The service switch is in the *ON* position; the gas sampling probe is retracted from the kiln (see *Operating the service switch* on page 159).
- The EMERGENCY STOP switch is pressed.

**Procedure**   For extensive work on the probe tip (e.g. when replacing the filter) it is advisable to swing the probe out to the right so that you can access the tip area more easily. Swing the probe tip back in after replacing the filter.



**Swinging the probe tip out**

Proceed as follows:

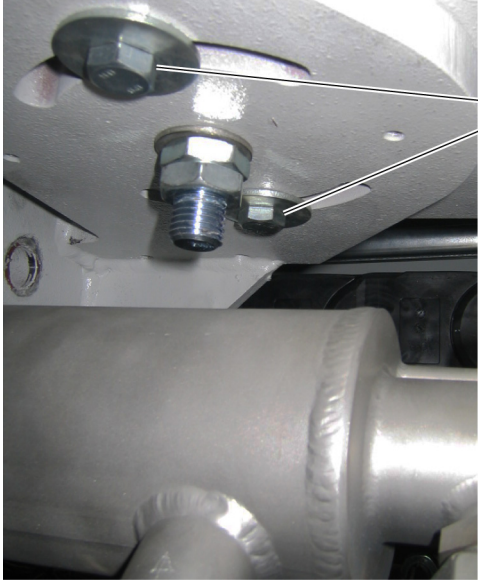
Step	Procedure
1	Allow gas sampling probe to cool down. <b>WARNING!</b> Risk of burning in the event of contact with the hot probe. <b>Do not touch the probe until it has cooled down to below 50 °C.</b>
2	Unscrew the adjustment screws <b>(1)</b> on the probe carriage until you can swing the probe out. 
3	Swing the probe out to the right.

**Instructions:  
replacing the intake  
filter**

Proceed as follows:

Step	Procedure
1	In controller: extend the plunger. <b>Path:</b> Operation ► Probe ► Plunger Action
2	Manually lock the shutter.
3	Using a wrench, unscrew the plunger (8-10 rotations) and pull it out. <b>CAUTION!</b> Do not touch the filter element when performing this and the subsequent steps!
4	Clean the thread filter element.
5	Wrap PTFE tape around the thread.
6	Insert filter into probe pipe, inserting the inside gas pipe into the filter element as you do.
7	Tighten moderately with a wrench.
8	Manually unlock the shutter.
9	In controller: retract the plunger. <b>Path:</b> Operation ► Probe ► Plunger Action

**Swinging the probe  
tip back in**

If you cleaned the probe tip while it was swung out, proceed as follows before resuming measurements:

Step	Procedure
1	Swing probe back in.
2	Tighten adjustment screws.
3	Check probe alignment in relation to the duct opening, if necessary correct the position after unscrewing the adjustment screws again.
4	Turn service switch back to <i>OFF</i> position.
5	Inserting probe again. <b>Path:</b> Operation ► Probe ► Probe Action ► Insert <b>WARNING!</b> The probe moves into the kiln. <b>Do not stand in the area of travel of the probe or probe carriage.</b>
6	In controller: wait for heat-up time until the following error messages disappear: "C. Water Return Temp. MIN" <b>Path:</b> Diagnosis ► Message
7	In controller: switch gas sampling probe to AUTOMATIC mode: <b>Path:</b> Operation ► Automatic on / off

# Gas sampling probe H: Replacing membrane pump membranes

**Maintenance interval**   ▪ twice yearly

## Safety measures

### **▲WARNING**

Always take the following safety measures when performing this work:

- ▶ Wear the general protective equipment.
- ▶ Turn the service switch to *ON* and secure the service switch against unauthorized switching (with a padlock).
- ▶ Additionally press the EMERGENCY STOP switch.
- ▶ Do not enter the danger area around the retractor until it is at standstill and the warning lamps and buzzer are off and the flap valve is closed.
- ▶ Do not perform the work until the gas sampling system has cooled down.

Explanation of safety measures: *Safety regulations for maintenance work on page 156.*

**Tools required**   ▪ Control cabinet key to open the control cabinet

**Requirements**   The following conditions must be met:

- The service switch is in the *ON* position, the gas sampling probe is retracted from the kiln (see *Operating the service switch* on page 159).
- The EMERGENCY STOP switch is pressed.

**Instructions**   Perform the following steps to replace the structural diaphragm of the pre-suction pump -M71:

Step	Procedure
1	Open the control cabinet.
2	Power off pump at the circuit breaker -F34.
3	Clean outside of pump housing.
4	Unscrew the four screws to open the pump housing.
5	Detach the pump tubes, remove the pump -M71 and clean it externally.

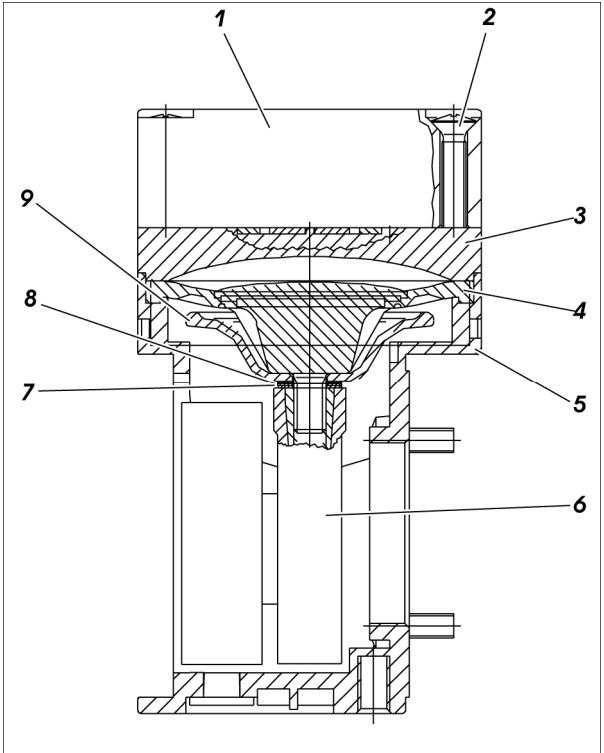
Step	Procedure
<p><b>6</b></p>	<p>Mark the head cap <b>(1)</b>, spacer plate <b>(3)</b> and housing <b>(5)</b> with a felt pen. This prevents the possibility of these parts being fitted incorrectly when the pump is reassembled later.</p> 
<p><b>7</b></p>	<p>Unscrew the four head-cover screws <b>(2)</b> and remove the head cap along with the spacer plate from the pump housing.</p>
<p><b>8</b></p>	<p>Move the structural diaphragm by rotating the fan impeller to its upper return point.</p>
<p><b>9</b></p>	<p>Lift the structural diaphragm <b>(4)</b> holding opposite sides and screw it out counter-clockwise. Make sure that the cup spring <b>(7)</b> and the adjusting washer(s) <b>(8)</b> do not fall off the threaded bolt of the structural diaphragm into the housing.</p>
<p><b>10</b></p>	<p>Remove the cup spring <b>(7)</b>, adjusting washer(s) <b>(8)</b> and support bowl <b>(9)</b> from the threaded bolt of the structural diaphragm and store them.</p>
<p><b>11</b></p>	<p>Check all the parts for dirt and, if necessary, clean them with a dry cloth or compressed air.</p>
<p><b>12</b></p>	<p>Push the support bowl <b>(9)</b>, the adjusting washer(s) <b>(8)</b> and the cup spring <b>(7)</b> onto the threaded bolt of the new structural diaphragm in this order.</p> <p><b>Note:</b> The cup edge of the spring must face the structural diaphragm!</p>
<p><b>13</b></p>	<p>Move the connecting rod <b>(6)</b> to its upper return point.</p>
<p><b>14</b></p>	<p>Screw the new structure diaphragm with support bowl, adjusting washer(s) and cup spring onto the connecting rod and tighten to finger tightness.</p>
<p><b>15</b></p>	<p>Reconnect pump hoses.</p>
<p><b>16</b></p>	<p>Screw pump housing back on.</p>

Step	Procedure
17	Switch circuit breaker -F34 back on.
18	Close control cabinet again.
19	Unlock EMERGENCY STOP switch, turn service switch back to <i>OFF</i> position and insert probe again using the controller. <b>WARNING!</b> Probe moves into the kiln. <b>Do not stand in the area of travel of the probe or probe carriage until the probe is completely inserted into the kiln and the warning lamps go out.</b>

## Gas sampling probe 60S: Removing incrustations

**Maintenance interval**   ▪ daily (or as required)

### Safety measures

**▲WARNING**

Always take the following safety measures when performing this work:

- ▶ Wear a face mask against heat, heat-proof gloves and protective welder's clothing.
- ▶ Turn the service switch to *ON* and secure the service switch against unauthorized switching (with a padlock).
- ▶ Additionally press the EMERGENCY STOP switch.
- ▶ Do not enter the danger area around the retractor until it is at standstill and the warning lamps and buzzer are off and the flap valve is closed.
- ▶ Do not perform the work until the gas sampling system has cooled down.
- ▶ Lock the shutter when you start the work, unlock the shutter after finishing the work.
- ▶ Always keep the floor around the gas sampling system clean and dry.

Explanation of safety measures: *Safety regulations for maintenance work on page 156.*

### Tools required

- Chisel
- Hammer

**Mechanical probe tip cleaning**

Proceed as follows:

Step	Procedure
1	Switch service switch to <i>ON</i> position (see <i>Operating the service switch</i> on page 159), press EMERGENCY STOP switch and allow gas sampling system to cool down. <b>WARNING!</b> Risk of burning in the event of contact with the hot probe. <b>Do not touch the probe until it has cooled down to below 50 °C.</b>
2	Manually lock the shutter.
3	Mechanical cleaning: Remove incrustations on the probe tip by hitting them with a chisel. The direction of impact must be parallel to the longitudinal axis of the probe in order to prevent massive damage to the gas sampling probe. The size of the tool must suit the sampling aperture in order to prevent massive damage. <b>Note:</b> The probe must only be cleaned mechanically. Do not use chemicals (acids, lyes, etc.) for cleaning.
4	Manually unlock the shutter.
5	In controller: insert the probe. <b>Path:</b> Operation ► Probe ► Probe Action ► Insert <b>WARNING!</b> The probe moves into the kiln. <b>Do not stand in the area of travel of the probe or probe carriage.</b>
6	In controller: launch compressed-air cleaning. <b>Path:</b> Operation ► Probe ► Cleaning ► Manual Cleaning
7	In controller: retract the probe. <b>Path:</b> Operation ► Probe ► Probe Action ► Retract <b>WARNING!</b> The probe moves out of the kiln. <b>Do not stand in the area of travel of the probe or probe carriage.</b>
8	Check sampling aperture again, repeat mechanical cleaning if necessary.
9	Turn service switch to the <i>OFF</i> position, unlock the EMERGENCY STOP switch.
10	In controller: insert the probe again. <b>Path:</b> Operation ► Probe ► Probe Action ► Insert <b>WARNING!</b> The probe moves into the kiln. <b>Do not stand in the area of travel of the probe or probe carriage.</b>
11	In controller: wait for heat-up time until the following error messages disappear: "C. Water Return Temp. MIN" <b>Path:</b> Diagnosis ► Message
12	In controller: switch gas sampling probe to AUTOMATIC mode: <b>Path:</b> Operation ► Automatic on / off

## Gas sampling probe 60S: Cleaning or replacing the outlet filter

**Meaning** Filter service life depends on the operating conditions. If necessary, remove it in order to inspect it and mechanically clean off any dirt or replace it. If the filter stone is damaged it must be replaced with a new one.

**Maintenance interval** ▪ once a year or as required

### Safety measures

#### **WARNING**

Always take the following safety measures when performing this work:

- ▶ Wear the general protective equipment.
- ▶ Turn the service switch to *ON* and secure the service switch against unauthorized switching (with a padlock).
- ▶ Additionally press the EMERGENCY STOP switch.
- ▶ Do not enter the danger area around the retractor until it is at standstill and the warning lamps and buzzer are off and the flap valve is closed.
- ▶ Do not perform the work until the gas sampling system has cooled down.

Explanation of safety measures: *Safety regulations for maintenance work on page 156.*

### Required tools and spare parts

- Wrench SW 22
- Socket head screwdriver
- New filter stone

### Requirements

The following conditions must be met:

- The service switch is in the *ON* position, the gas sampling probe is retracted from the kiln (see *Operating the service switch* on page 159).
- The EMERGENCY STOP switch is pressed.

### Instructions

Proceed as follows:

Step	Procedure
1	Allow gas sampling probe to cool down. <b>WARNING!</b> Risk of burning in the event of contact with the hot probe. <b>Do not touch the probe until it has cooled down to below 50 °C.</b>

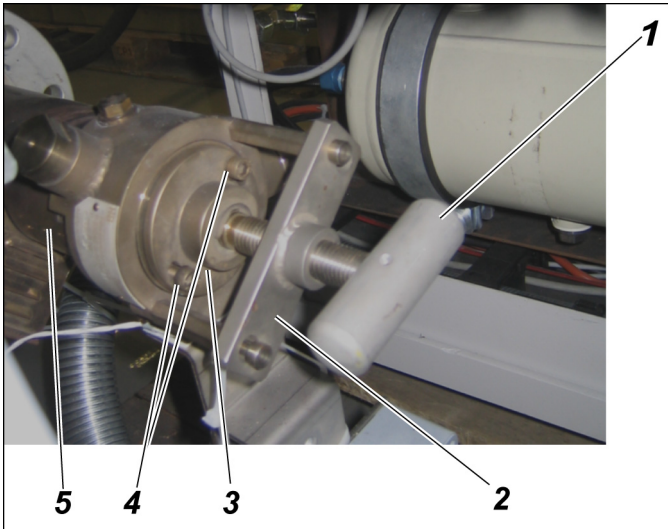
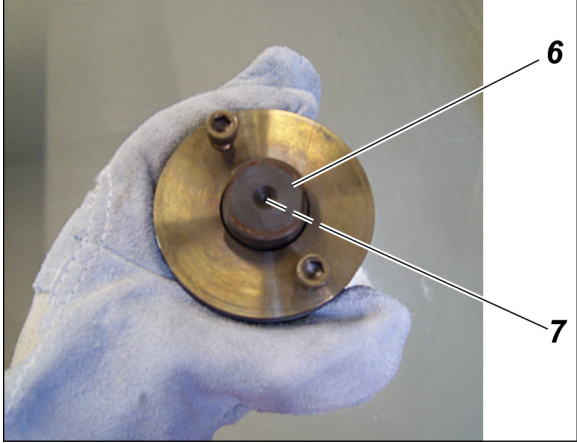

Step	Procedure
2	<p>Turn the T-handle (1) of the filter detaching device counter-clockwise. This pulls the filter insert over the detaching disk (3) out of the casing (5).</p> 
3	Turn bridge 2 until it can be pulled off from the bridge holder through the elongated holes.
4	Pull filter insert with bridge and detaching disk out.
5	Turn detaching disk until it can be pulled off from the hexagon screws (4) over the elongated holes.
6	<p>Mechanically clean the filter stone.</p> <p><b>WARNING!</b> The filter insert may be soiled with toxic and corrosive substances depending on the substances with which it comes into contact in operation. <b>Wear appropriate protective clothing when cleaning.</b></p>
7	If the filter stone needs to be replaced: Unscrew locking screw (6) with open-end spanner.
8	<p>Screw the locking screw (6) out by hand.</p> 
9	Unscrew the hex screw (7) below with an Allen key.

Step	Procedure
10	Take out the filter stone. <b>WARNING!</b> The filter insert may be soiled with toxic and corrosive substances depending on the substances with which it comes into contact in operation. <b>Wear appropriate protective clothing when cleaning.</b>
11	Replace filter stone.
12	If necessary, replace seals (see <i>Gas sampling probe 60S: Replacing the seal set</i> on page 187).
13	Reassemble filter insert and push back into casing, tighten T-handle.
14	Unlock EMERGENCY STOP switch, turn service switch back to <i>OFF</i> position and insert probe again using the controller. <b>WARNING!</b> Probe moves into the kiln. <b>Do not stand in the area of travel of the probe or probe carriage until the probe is completely inserted into the kiln and the warning lamps go out.</b>

# Gas sampling probe 60S: Replacing the seal set

**Maintenance interval**   ▪ twice yearly

## Safety measures

### **WARNING**

Always take the following safety measures when performing this work:

- ▶ Wear the general protective equipment.
- ▶ Turn the service switch to *ON* and secure the service switch against unauthorized switching (with a padlock).
- ▶ Additionally press the EMERGENCY STOP switch.
- ▶ Do not enter the danger area around the retractor until it is at standstill and the warning lamps and buzzer are off and the flap valve is closed.
- ▶ Do not perform the work until the gas sampling system has cooled down.

Explanation of safety measures: *Safety regulations for maintenance work on page 156.*

## Tools required

- Wrench SW 22
- Socket head screwdriver
- O-rings

## Requirements

The following conditions must be met:

- The service switch is in the *ON* position, the gas sampling probe is completely retracted from the kiln (see *Operating the service switch* on page 159).
- The EMERGENCY STOP switch is pressed.

## Instructions

Proceed as follows:

Step	Procedure
1	Allow gas sampling probe to cool down. <b>WARNING!</b> Risk of burning in the event of contact with the hot probe. <b>Do not touch the probe until it has cooled down to below 50 °C.</b>

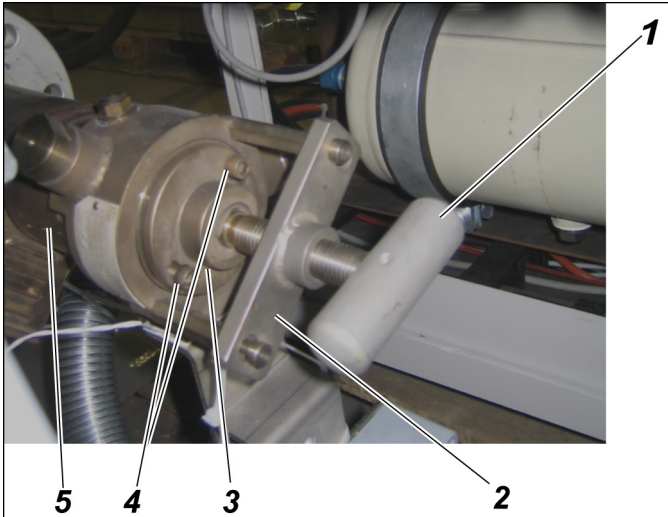
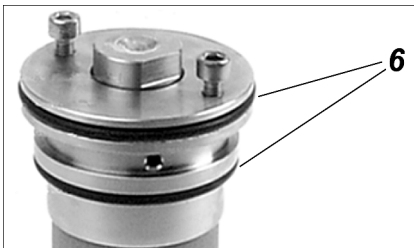
Step	Procedure
2	<p>Turn the T-handle (1) of the filter detaching device counter-clockwise. This pulls the filter insert over the detaching disk (3) out of the casing (5).</p> 
3	Turn bridge (2) until it can be pulled off from the bridge holder through the elongated holes.
4	Pull filter insert with bridge and detaching disk out.
5	Turn detaching disk until it can be pulled off from the hexagon screws (4) over the elongated holes.
6	<p>If necessary, mechanically clean the filter stone.</p> <p><b>WARNING!</b> The filter insert may be soiled with toxic and corrosive substances depending on the substances with which it comes into contact in operation. <b>Wear appropriate protective clothing when cleaning.</b></p>
7	<p>Replace O-rings (6).</p> <p><b>Note:</b> The O-rings do not need to be re-greased.</p> 
8	Reassemble filter insert and push back into casing, tighten T-handle.
9	<p>Unlock EMERGENCY STOP switch, turn service switch back to OFF position and insert probe again using the controller.</p> <p><b>WARNING!</b> Probe moves into the kiln. <b>Do not stand in the area of travel of the probe or probe carriage until the probe is completely inserted into the kiln and the warning lamps go out.</b></p>

## Probe retractor: Checking filter/pressure control combination

**Maintenance interval**   ▪ twice yearly

### Safety measures

#### **WARNING**

Always take the following safety measures when performing this work:

- ▶ Wear the general protective equipment.
- ▶ Turn the service switch to *ON* and secure the service switch against unauthorized switching (with a padlock).
- ▶ Do not enter the danger area around the retractor until it is at standstill and the warning lamps and buzzer are off and the flap valve is closed.
- ▶ Do not perform the work until the gas sampling system has cooled down.
- ▶ When the warning lamps light up or the warning buzzer buzzes, leave the danger area around the probe retractor immediately as the probe is about to move at any moment.
- ▶ Press the EMERGENCY STOP switch immediately if anyone is still in the danger area around the retractor after the warning lamps light up or the warning buzzer buzzes.
- ▶ Avoid contact with lubricating oil.
- ▶ Wash any lubricating oil off the skin immediately with water and soap.
- ▶ If any lubricating oil gets in the eyes despite protective glasses, rinse them thoroughly under running water, holding the eyelids open.
- ▶ Observe instructions in the lubricating oil manufacturer's safety data sheet.

Explanation of safety measures: *Safety regulations for maintenance work on page 156.*

### Requirements

The following conditions must be met:

- The service switch is in the *ON* position; the gas sampling probe is retracted from the kiln (see *Operating the service switch* on page 159).

## Instructions

Perform the following steps to check the filter/pressure control combination -J53:

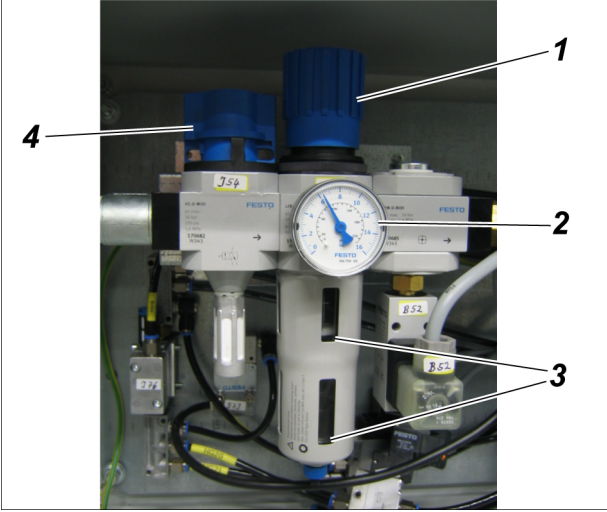
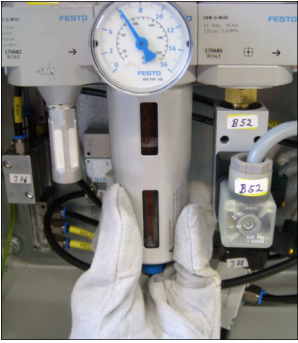
Step	Procedure
1	<p>Check holding pressure set on manometer (2) (6 bar (6000 hPa)). In the event of deviations, use knob (1) above to adjust.</p> 
2	<p>No droplets of liquid or dust deposits must be visible in the inspection window (3).</p>
3	<p>If there are any impurities, shut off the compressed-air inlet at the shut-off valve -J54 (4).</p>
4	<p>Unscrew the filter casing by turning it counter-clockwise, remove impurities and clean the inside of the filter casing with a cloth.</p> 
5	<p>Screw filter casing back on.</p> <p><b>Note:</b> During this procedure, also check central compressed-air supply for soiling. The system must not be switched on again until all impurities have been completely removed.</p>
6	<p>Open the compressed-air inlet again at the shut-off valve -J54 (4).</p>
7	<p>Turn service switch back to <i>OFF</i> position and insert probe again using the controller.</p> <p><b>WARNING!</b> Probe moves into the kiln. <b>Do not stand in the area of travel of the probe or probe carriage until the probe is completely inserted into the kiln and the warning lamps go out.</b></p>

## Probe retractor: Checking and replacing the filter muffler

**Maintenance interval**   ▪ twice yearly

### Safety measures

#### **WARNING**

Always take the following safety measures when performing this work:

- ▶ Wear the general protective equipment.
- ▶ Turn the service switch to *ON* and secure the service switch against unauthorized switching (with a padlock).
- ▶ Do not enter the danger area around the retractor until it is at standstill and the warning lamps and buzzer are off and the flap valve is closed.
- ▶ Do not perform the work until the gas sampling system has cooled down.
- ▶ When the warning lamps light up or the warning buzzer buzzes, leave the danger area around the probe retractor immediately as the probe is about to move at any moment.
- ▶ Press the EMERGENCY STOP switch immediately if anyone is still in the danger area around the retractor after the warning lamps light up or the warning buzzer buzzes.
- ▶ Avoid contact with lubricating oil.
- ▶ Wash any lubricating oil off the skin immediately with water and soap.
- ▶ If any lubricating oil gets in the eyes despite protective glasses, rinse them thoroughly under running water, holding the eyelids open.
- ▶ Observe instructions in the lubricating oil manufacturer's safety data sheet.

Explanation of safety measures: *Safety regulations for maintenance work on page 156.*



### Requirements

The following conditions must be met:

- The service switch is in the *ON* position; the gas sampling probe is completely retracted from the kiln (see *Operating the service switch* on page 159).

**Instructions**

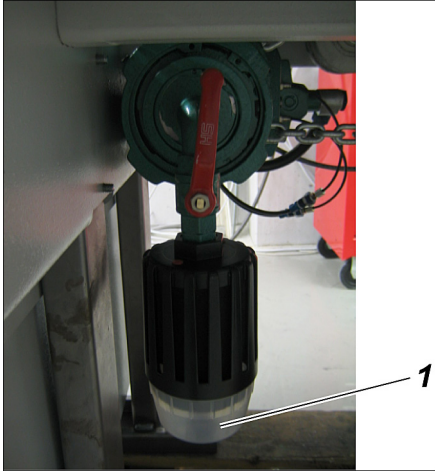
Perform the following steps to check the filter muffler on the compressed-air motor (-J83):

Step	Procedure
1	<p>Pull the drip cup (1) off the filter muffler -J83.</p> 
2	<p>Unscrew filter element.</p> 
3	<p>Inspect and, if necessary, replace filter element.</p>
4	<p>Screw filter element back on.</p>
5	<p>Put the drip cup back on.</p>
6	<p>Unlock EMERGENCY STOP switch, turn service switch back to OFF position and insert probe again using the controller.</p> <p><b>WARNING!</b> Probe moves into the kiln. Do not stand in the area of travel of the probe or probe carriage until the probe is completely inserted into the kiln and the warning lamps go out.</p>



## Probe retractor: Checking and topping up the oiler

<b>Meaning</b>	A compressed-air oiler at the end of the probe retractor ensures adequate delivery of lubricant to the compressed-air motor. Check oil level and oil delivery rate before start-up and at regular intervals during operations.
<b>Maintenance interval</b>	<ul style="list-style-type: none"><li>▪ twice yearly</li></ul>
<b>Safety measures</b>	<p><b>⚠ WARNING</b></p> <p>Always take the following safety measures when performing this work:</p> <ul style="list-style-type: none"><li>▶ Wear the general protective equipment.</li><li>▶ Turn the service switch to <i>ON</i> and secure the service switch against unauthorized switching (with a padlock).</li><li>▶ Do not enter the danger area around the retractor until it is at standstill and the warning lamps and buzzer are off and the flap valve is closed.</li><li>▶ Do not perform the work until the gas sampling system has cooled down.</li><li>▶ When the warning lamps light up or the warning buzzer buzzes, leave the danger area around the probe retractor immediately as the probe is about to move at any moment.</li><li>▶ Press the EMERGENCY STOP switch immediately if anyone is still in the danger area around the retractor after the warning lamps light up or the warning buzzer buzzes.</li><li>▶ Avoid contact with lubricating oil.</li><li>▶ Wash any lubricating oil off the skin immediately with water and soap.</li><li>▶ If any lubricating oil gets in the eyes despite protective glasses, rinse them thoroughly under running water, holding the eyelids open.</li><li>▶ Observe instructions in the lubricating oil manufacturer's safety data sheet.</li><li>▶ Always keep the floor around the gas sampling system clean and dry.</li></ul> <p>Explanation of safety measures: <i>Safety regulations for maintenance work on page 156.</i></p>
<b>Lubricating oil</b>	Lubricating oil "D" DIN 51502, kinematic viscosity 30 mm <sup>2</sup> /s(cST) at 40 °C (ISO VG 32, DIN 51519)
<b>Tools required</b>	<ul style="list-style-type: none"><li>▪ Screwdriver, short (to adjust oil delivery rate)</li></ul>
<b>Requirements</b>	<p>The following conditions must be met:</p> <ul style="list-style-type: none"><li>▪ The service switch is in the <i>ON</i> position, the gas sampling probe is retracted from the kiln (see <i>Operating the service switch</i> on page 159).</li></ul>

**Instructions:  
checking oil level**

How to check oil level on the compressed-air oiler -J74:

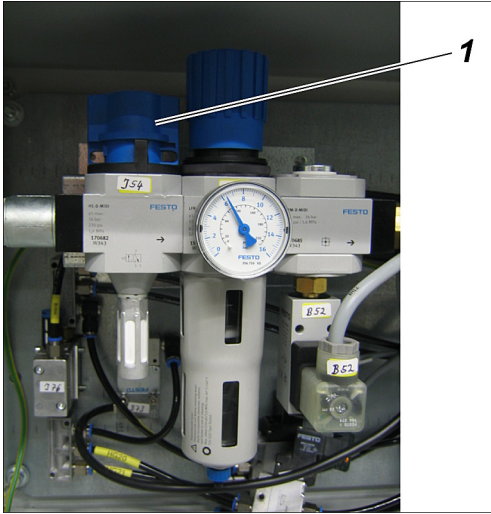
Step	Procedure
1	<p>Check oil level in the tank inspection windows on the compressed-air oiler -J74.</p> <p><b>Guidelines:</b></p> <p><b>Minimum:</b> Bottom edge of the bottom inspection window</p> <p><b>Maximum:</b> Top quarter in the top inspection window</p> 
2	<p>Shut off the compressed-air using the gate valve -J54 (1) in the pneumatic box of the probe retractor.</p> 
3	<p>Completely drain the compressed-air tank (if present).</p>
4	<p>Unscrew the tank on the compressed-air oiler -J74 by turning it counter-clockwise.</p>
5	<p>Fill oil up to the top quarter of the top inspection window and screw tank back on.</p>
6	<p>Remove any oil residue with a cloth.</p>
7	<p>Open the compressed-air gate valve -J54 (1) again.</p>
8	<p>Turn service switch back to <i>OFF</i> position and insert probe again using the controller.</p> <p><b>WARNING!</b> Probe moves into the kiln. <b>Do not stand in the area of travel of the probe or probe carriage until the probe is completely inserted into the kiln and the warning lamps go out.</b></p>

**Instructions:  
checking oil delivery  
rate**

How to check oil delivery rate on the compressed-air oiler -J74 (note: two people should perform this job):

Step	Procedure
1	<p>Turn the setting screw in the inspection glass to modify the quantity of oil.</p> <p>Meaning of the directions of rotation: <b>counter-clockwise:</b> more oil <b>clockwise:</b> less oil</p>  <p><b>Note:</b> The compressed-air oiler -J74 must deliver approx. 2 drops of oil per insertion/retraction cycle. If this is not ensured, the compressed-air motor may get damaged or this may lead to excessive soiling of the muffler.</p>
2	Move probe in/out to check oil quantity, modify again if necessary.

## Probe retractor: Checking and tightening the drive chain

**Meaning** Maintain adequate drive chain tension so as to prevent damage to the retractor.

**Maintenance interval** ▪ weekly or as required

### Safety measures



Always take the following safety measures when performing this work:

- ▶ Wear the general protective equipment.
- ▶ Turn the service switch to *ON* and secure the service switch against unauthorized switching (with a padlock).
- ▶ Additionally press the EMERGENCY STOP switch.
- ▶ Do not enter the danger area around the retractor until it is at standstill and the warning lamps and buzzer are off and the flap valve is closed.
- ▶ Do not perform the work until the gas sampling system has cooled down.

Explanation of safety measures: *Safety regulations for maintenance work on page 156.*

### Requirements

The following conditions must be met:

- The service switch is in the *ON* position; the gas sampling probe is retracted from the kiln (see *Operating the service switch* on page 159).
- The EMERGENCY STOP switch is pressed.

## Instructions

How to check drive tension:

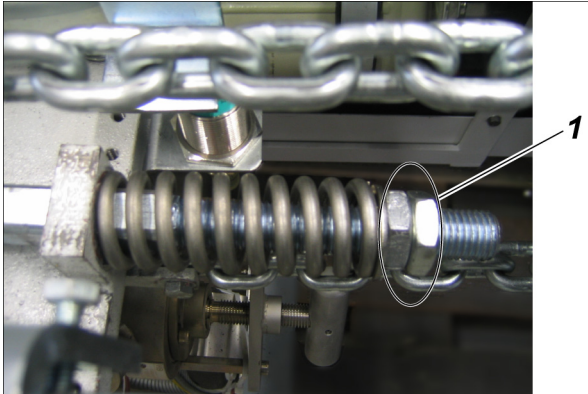
Step	Procedure
1	<p>Check drive chain tension.</p> <p><b>Target requirement:</b> The upper chain is adequately tensioned when you can pull it down approx. 4-5 cm by hand.</p>
2	<p>If the chain droops or if you can pull it down further:</p> <p>Tension the drive chain with the chain tensioner in the probe carriage using the adjustment nuts <b>(1)</b> such that the upper part of the chain does not droop onto the lower part of the chain.</p> <p><b>Note:</b> Ensure that the drive chain is not twisted. Also, ensure adequate tightening of the adjustment nuts.</p> 
3	<p>Unlock EMERGENCY STOP switch, turn service switch back to OFF position and insert probe again using the controller.</p> <p><b>WARNING!</b> Probe moves into the kiln. <b>Do not stand in the area of travel of the probe or probe carriage until the probe is completely inserted into the kiln and the warning lamps go out.</b></p>

## Probe retractor: Checking and, if necessary, adjusting the position of the probe

### Probe position

Due to changes entailed by the process or the system it may be necessary to change the position of the gas sampling probe. Note that the tip of the probe should be max. 30 cm in the rotary kiln after start-up. The gas sampling probe must not be inserted further than absolutely necessary into the rotary kiln in order to minimize impacts on the unprotected area of the probe caused by the process.

### Maintenance interval

- every six months or as required (kiln conversion work, process changes)

### Safety measures

#### **⚠ WARNING**

Always take the following safety measures when performing this work:

- ▶ Wear the general protective equipment.
- ▶ Before commencing adjustment work, turn the service switch to *ON* and secure the service switch against unauthorized switching (with a padlock).
- ▶ Additionally press the EMERGENCY STOP switch.
- ▶ Do not enter the danger area around the retractor until it is at standstill and the warning lamps and buzzer are off and the flap valve is closed.
- ▶ Do not perform the adjustment work until the gas sampling system has cooled down.

Explanation of safety measures: *Safety regulations for maintenance work on page 156.*

### Instructions: checking probe position

How to check probe position:

Step	Procedure
1	With the probe inserted, check the distance between the flange and the pipe sealing device. <b>Target requirement:</b> The flange must be touching.
2	If this target requirement is not met, adjust the probe by means of the following actions: <ul style="list-style-type: none"> <li>▪ Adjust the tube sealing device</li> <li>▪ change vertical position</li> <li>▪ change horizontal position.</li> </ul>

### Instructions: adjusting the tube sealing device

Proceed as follows to realign the tube sealing device:

Step	Procedure
1	Turn service switch to <i>ON</i> position. <b>WARNING!</b> Gas sampling probe moves out of the kiln. <b>Do not stand in the area of travel of the gas sampling probe or probe carriage until the probe is completely retracted and the warning lamps go out.</b>
2	Press EMERGENCY STOP switch and allow gas sampling probe to cool down. <b>WARNING!</b> Risk of burning in the event of contact with the hot probe. <b>Do not touch the probe until it has cooled down to below 50 °C.</b>

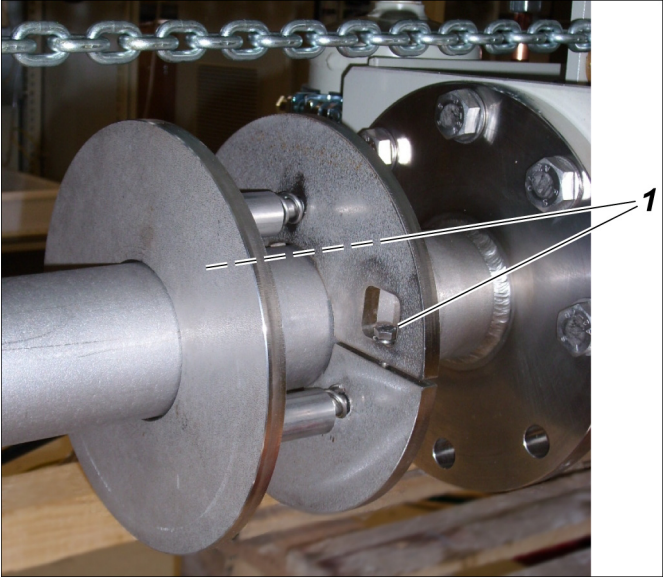
Step	Procedure
3	<p>Unscrew clamp screws (1) on the pipe sealing device until it is easy to move. If necessary, clean the outside of the probe pipe first.</p> 
4	Move pipe sealing device by the required amount.
5	Tighten clamp screws. Make sure that one of the springs is in six 'o' clock position.
6	<p>Turn service switch back to <i>OFF</i> position and insert probe again using the controller.</p> <p><b>WARNING!</b> Probe moves into the kiln. <b>Do not stand in the area of travel of the probe or probe carriage until the probe is completely inserted into the kiln and the warning lamps go out.</b></p>

**Instructions: change vertical position**

Proceed as follows to change the vertical alignment of the gas sampling probe:

Step	Procedure
1	<p>Turn service switch to <i>ON</i> position.</p> <p><b>WARNING!</b> Gas sampling probe moves out of the kiln. <b>Do not stand in the area of travel of the gas sampling probe or probe carriage until the probe is completely retracted and the warning lamps go out.</b></p>
2	<p>Press EMERGENCY STOP switch and allow gas sampling probe to cool down.</p> <p><b>WARNING!</b> Risk of burning in the event of contact with the hot probe. <b>Do not touch the probe until it has cooled down to below 50 °C.</b></p>
3	Unscrew counter nuts (1) on probe carriage.

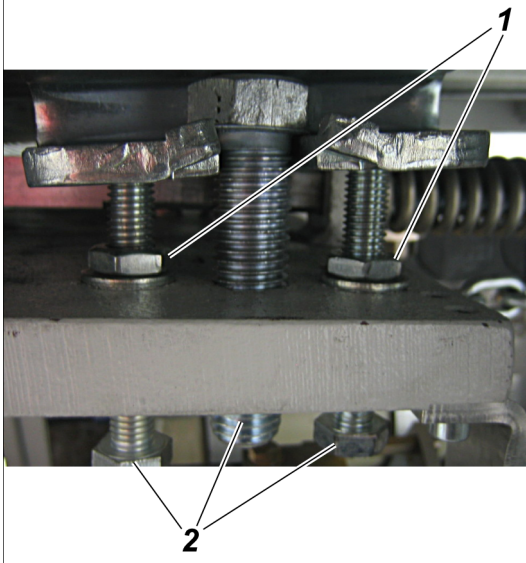
Step	Procedure
4	<p>Adjust adjustment screws <b>(2)</b> until the desired position is achieved. Ensure even changes on both sides of the probe carriage.</p> <p><b>Note:</b> To make work easier, have another person lift up the probe tip slightly.</p> 
5	Perform steps 1 to 2 on the other side of the probe carriage so as to ensure equal distance to the rails.
6	Tighten counter nuts <b>(1)</b> .
7	<p>Unlock EMERGENCY STOP switch, turn service switch back to <i>OFF</i> position and insert probe again using the controller. Check the position of the entire sampling pipe in relation to the mounting flange, adjust if necessary.</p> <p><b>WARNING!</b> Probe moves into the kiln. <b>Do not stand in the area of travel of the probe or probe carriage until the probe is completely inserted into the kiln and the warning lamps go out.</b></p>

**After changing vertical position**

If you have changed the position of the probe as described, you must then check and, if necessary, adjust the end position sensor. Follow the instructions in *Probe retractor: Checking and, if necessary, adjusting the position indicator (probe end position)* on page 202.

**Instructions: changing horizontal position**

Proceed as follows to change the horizontal alignment of the gas sampling probe:

Step	Procedure
1	<p>Turn service switch to <i>ON</i> position.</p> <p><b>WARNING!</b> Gas sampling probe moves out of the kiln. <b>Do not stand in the area of travel of the gas sampling probe or probe carriage until the probe is completely retracted and the warning lamps go out.</b></p>
2	<p>Press EMERGENCY STOP switch and allow gas sampling probe to cool down.</p> <p><b>WARNING!</b> Risk of burning in the event of contact with the hot probe. <b>Do not touch the probe until it has cooled down to below 50 °C.</b></p>

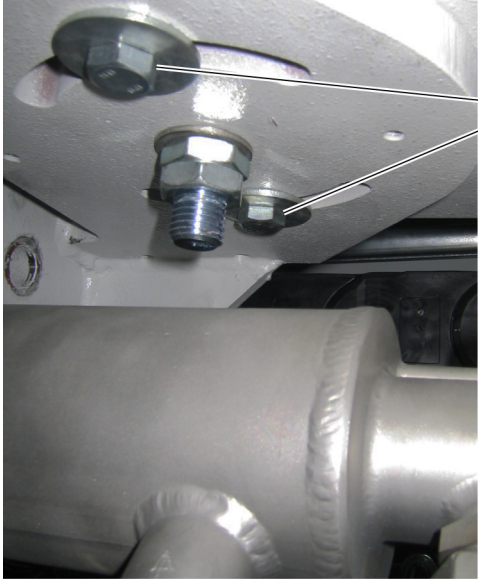

Step	Procedure
3	<p>Unscrew adjustment screws <b>(1)</b>, turn probe until the desired position is achieved.</p> <p><b>Note:</b> To make work easier, have another person lift up the probe tip slightly.</p> 
4	Tighten adjustment screws.
5	<p>Unlock EMERGENCY STOP switch, turn service switch back to <i>OFF</i> position and insert probe again using the controller. Check the position of the entire sampling pipe in relation to the mounting flange, adjust if necessary.</p> <p><b>WARNING!</b> Probe moves into the kiln. <b>Do not stand in the area of travel of the probe or probe carriage until the probe is completely inserted into the kiln and the warning lamps go out.</b></p>

**After changing horizontal position**

If you have changed the position of the probe as described, you must then check and, if necessary, adjust the end position sensor. Follow the instructions in *Probe retractor: Checking and, if necessary, adjusting the position indicator (probe end position)* on page 202.

## Probe retractor: Checking and, if necessary, adjusting the position indicator (probe end position)

**Meaning** During operation, the probe position indicators may need to be readjusted. This can be caused, for example, by loose fastening elements.

**Maintenance interval** ▪ every six months (or as required)

**Illustration** There are two inductive position indicators and one mechanical position indicator in the probe retractor. The two inductive (**1, 2**) indicators are mounted on the probe carriage and travel together with the probe, the mechanical position indicator (**3**) is permanently mounted on the retractor.

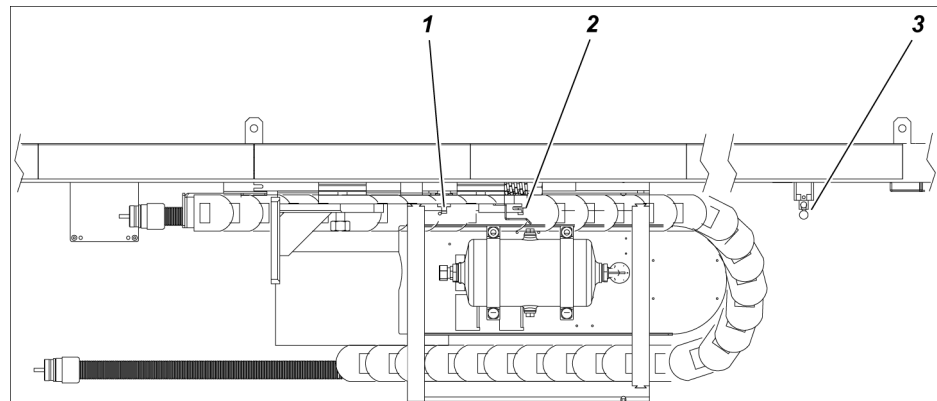

**Function of the position indicators** The above-mentioned position indicators signal to the controller that the gas sampling probe has reached the respective position. The position indicators given in the above illustration signal the following positions:

No.	Limit switch	Signal/position
<b>1</b>	Inductive position indicator -B71	The probe is completely inserted into the kiln.
<b>2</b>	Inductive position indicator -B72	The probe is completely retracted.
<b>3</b>	Mechanical position indicator -S72	The probe is retracted so far that it has reached the mechanical limit of the pneumatic motor.

### Safety measures

#### **⚠ WARNING**

Always take the following safety measures when performing this work:

- ▶ Wear the general protective equipment.
- ▶ Before commencing any work on the gas sampling system, turn the service switch to *ON* and secure the service switch against unauthorized switching (with a padlock).
- ▶ Additionally press the EMERGENCY STOP switch before working on the retractor or probe.
- ▶ Do not enter the danger area around the retractor until it is at standstill and the warning lamps and buzzer are off and the flap valve is closed.
- ▶ Do not perform the work until the gas sampling system has cooled down.

- ▶ When the warning lamps light up or the warning buzzer buzzes, leave the danger area around the probe retractor immediately as the probe is about to move at any moment.
- ▶ Press the EMERGENCY STOP switch immediately if anyone is still in the danger area around the retractor after the warning lamps light up or the warning buzzer buzzes.

**Instructions: rear end position**

Proceed as follow to readjust or reposition position indicators -B72/-S72:

Step	Procedure
1	Turn service switch to <i>ON</i> position. <b>WARNING!</b> Probe moves out of the kiln. <b>Do not stand in the area of travel of the probe or probe carriage until the probe is completely retracted out of the kiln and the warning lamps go out.</b>
2	Press EMERGENCY STOP switch.
3	<p>Unscrew lock screws on the contact plate <b>(1)</b> with an Allen key and push contact plate for inductive indicator -B72 until the controller displays the appropriate signal.</p> <div data-bbox="614 784 1236 1344" data-label="Image"> </div> <p>Proceed in the same way for mechanical position indicator -S72.</p> <p><b>Note:</b> If inductive indicator -B72 does not trigger despite the contact plate above it, check the height adjustment and adjust as necessary. The distance between the inductive indicator and the contact plate must be 3-6 mm.</p>
4	Tighten contact sheet with Allen key.
5	Unlock EMERGENCY STOP switch, turn service switch back to <i>OFF</i> position and insert probe again using the controller. <b>WARNING!</b> Probe moves into the kiln. <b>Do not stand in the area of travel of the probe or probe carriage until the probe is completely inserted into the kiln and the warning lamps go out.</b>

**Instructions: probe inserted position**

Proceed as follow to readjust or reposition position indicator -B71:

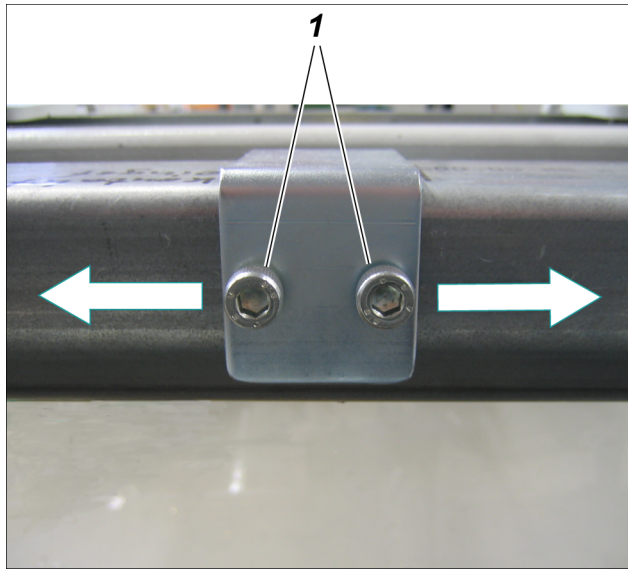
Step	Procedure
1	Press the Insert button to move the probe to the desired position. <b>Path:</b> Operation ► Probe ► Probe Action ► Insert
2	Determine necessary position of the contact plate, mark with an pen.
3	Turn service switch to <i>ON</i> position. <b>WARNING!</b> Probe moves out of the kiln. <b>Do not stand in the area of travel of the probe or probe carriage until the probe is completely retracted out of the kiln and the warning lamps go out.</b>
4	Press EMERGENCY STOP switch.
5	Unscrew lock screws on the contact plate <b>(1)</b> with an Allen key and push contact plate for inductive indicator -B71 until it reaches the marked position. 
6	Unlock EMERGENCY STOP switch.
7	Turn service switch to <i>OFF</i> position, then turn back to <i>ON</i> .
8	Press the Insert button to move the probe to the desired position until the controller displays the appropriate signal (e.g.: <b>Probe Inserted</b> display box in the <b>Probe Action</b> dialog changes from white to black). <b>Note:</b> If inductive indicator -B71 does not trigger despite the contact plate above it, check the height adjustment and adjust as necessary. The distance between the inductive indicator and the contact plate must be 3-6 mm.
9	Tighten contact sheet with Allen key.
10	Unlock EMERGENCY STOP switch, turn service switch back to <i>OFF</i> position and insert probe again using the controller. <b>WARNING!</b> Probe moves into the kiln. <b>Do not stand in the area of travel of the probe or probe carriage until the probe is completely inserted into the kiln and the warning lamps go out.</b>

## Probe retractor: Checking the bellows

**Maintenance interval**   ▪ every two years

### Safety measures

#### **▲WARNING**

Always take the following safety measures when performing this work:

- ▶ Wear the general protective equipment.
- ▶ Turn the service switch to *ON* and secure the service switch against unauthorized switching (with a padlock).
- ▶ Do not enter the danger area around the retractor until it is at standstill and the warning lamps and buzzer are off and the flap valve is closed.
- ▶ Do not touch the gas sampling system during and after operation.
- ▶ Do not touch the gas sampling system until it has cooled down to 50 °C.
- ▶ Do not approach the retracted probe until it has cooled down.
- ▶ When the warning lamps light up or the warning buzzer buzzes, leave the danger area around the probe retractor immediately as the probe is about to move at any moment.
- ▶ Press the EMERGENCY STOP switch immediately if anyone is still in the danger area around the retractor after the warning lamps light up or the warning buzzer buzzes.

Explanation of safety measures: *Safety regulations for maintenance work on page 156.*

### Requirements

The following conditions must be met:

- The service switch is in the *ON* position; the gas sampling probe is retracted from the kiln (see *Operating the service switch* on page 159).
- The EMERGENCY STOP switch is pressed.

### Instructions

Proceed as follows to check the bellows:

Step	Procedure
1	Unscrew the hose clamps on the cover.
2	Remove cover.
3	Check condition of retractor bellows: <ul style="list-style-type: none"><li>▪ general damage</li><li>▪ cracks</li><li>▪ abrasion</li></ul>
4	If the condition necessitates replacement, consult the service manual.
5	Put cover back on.
6	Fit and tighten hose clamps.
7	Unlock EMERGENCY STOP switch, turn service switch back to <i>OFF</i> position and insert gas sampling probe again using the controller. <b>WARNING!</b> Gas sampling probe moves into the kiln. <b>Do not stand in the area of travel of the gas sampling probe or probe carriage until the probe is completely inserted into the kiln and the warning lamps go out.</b>

## Cooling module: Vent the cooling-water circuit

**Maintenance interval**   ▪ every six months (or as required)

### Safety measures

#### **WARNING**

Always take the following safety measures when performing this work:

- ▶ Wear the general protective equipment.
- ▶ Turn the service switch to *ON* and secure the service switch against unauthorized switching (with a padlock).
- ▶ Only specialized electrical personnel may work on the electrical system.
- ▶ Do not perform work on the cooling-water circuit until the cooling water has cooled down.
- ▶ Avoid contact with the cooling water and the anti-freeze.
- ▶ Wash any cooling water and anti-freeze off the skin immediately with water and soap.
- ▶ If cooling water or anti-freeze gets in the eyes despite protective glasses, rinse them thoroughly under running water, holding the eyelids open.
- ▶ Observe instructions in the anti-freeze manufacturer's safety data sheet.
- ▶ Always keep the floor around the gas sampling system clean and dry.



Explanation of safety measures: *Safety regulations for maintenance work on page 156.*

**Tools required**   ▪ Control cabinet key to open the control cabinet

**Requirements**   The service switch is in the *ON* position, the gas sampling probe is retracted from the kiln (see *Operating the service switch* on page 159).

**Instructions**   Proceed as follows to vent the cooling-water circuit:

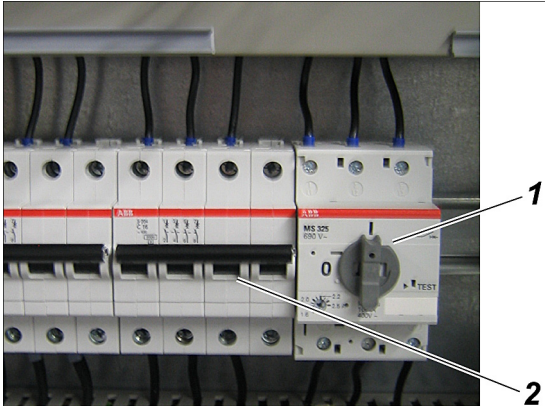
Step	Procedure
1	Open the control cabinet.
2	After retracting the probe wait until cooling-water temperature has dropped to 40 °C; you can monitor this on the controller: <b>Path:</b> Diagnosis ▶ Trends ▶ Cooling Water Return Temperature

Step	Procedure
3	<p>Switch off the cooling-water pump -M51 at the motor breaker -F37 (1).</p>  <p><b>Note:</b> You can also switch off the cooling-water pump at circuit breaker -F36 (2).</p>
4	Wait about 5 minutes.
5	<p>On the top of the heat exchanger: Unscrew cap and slowly open vent cock (red) so that air can escape.</p> 
6	Close drain valve on heat exchanger again as soon as only cooling water comes out.
7	Switch cooling-water pump -M51 on again at motor breaker -F37 (1) or at circuit breaker -F36 (2) for approx. 20 s.
8	Wait 5 minutes and vent again.
9	Repeat steps 7 and 8 until no more air comes out of the cooling-water circuit.
10	Check pressure of cooling water in the controller and top up if necessary (target cooling water pressure in cooled state: 1-1.5 bar (1000-1500 hPa)).
11	Switch cooling-water pump -M51 on again at motor breaker -F37 (1) or at circuit breaker -F36 (2) for approx. 20 s.
12	Close control cabinet again.
13	<p>Turn service switch back to OFF position and insert probe again using the controller.</p> <p><b>WARNING!</b> Probe moves into the kiln. Do not stand in the area of travel of the probe or probe carriage until the probe is completely inserted into the kiln and the warning lamps go out.</p>

## Cooling module: Checking and topping up cooling water

### Cooling-water requirements

The closed cooling-water circuit must be filled with approx. 50 l potable water (do not use anti-corrosive). In ambient temperatures below 0 °C admix approx. 20 l anti-freeze.

### Anti-freeze requirements

If ambient temperatures below 0 °C can be expected, you must admix anti-freeze. ABB recommends Glykol as anti-freeze. Anti-freeze with anti-corrosive additive is not permitted.

### Maintenance interval

Check cooling water pressure and cooling water flow rate on a daily basis. Completely replace the cooling water every two years.

### Safety measures

#### **WARNING**

Always take the following safety measures when performing this work:

- ▶ Wear the general protective equipment.
- ▶ Before commencing work on the cooling-water circuit, turn the service switch to *ON* and secure the service switch against unauthorized switching (with a padlock).
- ▶ Only specialized electrical personnel may work on the electrical system.
- ▶ Do not perform work on the cooling-water circuit until the cooling water has cooled down.
- ▶ Avoid contact with the cooling water and the anti-freeze.
- ▶ Wash any cooling water and anti-freeze off the skin immediately with water and soap.
- ▶ If cooling water or anti-freeze gets in the eyes despite protective glasses, rinse them thoroughly under running water, holding the eyelids open.
- ▶ Observe instructions in the anti-freeze manufacturer's safety data sheet.
- ▶ Always keep the floor around the gas sampling system clean and dry.

Explanation of safety measures: *Safety regulations for maintenance work on page 156.*

### Tools required

- Control cabinet key to open the control cabinet

### Checking cooling water



The following steps are necessary to check cooling water pressure and cooling water flow rate:

Step	Procedure
1	During operation, observe cooling water pressure and cooling water flow rate on the controller, Trends submenu.
2	Top up cooling water if <ul style="list-style-type: none"><li>▪ pressure drops below 2-2.5 bar (2000-2500 hPa) in operation</li><li>▪ or cooling water flow rate is &lt; 50 l/min.</li></ul>

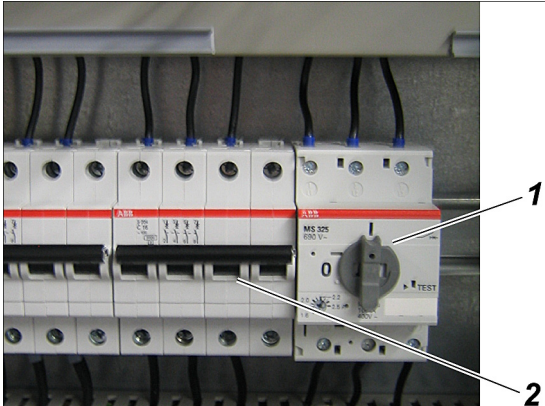

## Topping up cooling water

Proceed as follows to top up cooling water:

Step	Procedure
1	Turn service switch to <i>ON</i> position. <b>WARNING!</b> Actuating the service switch moves the probe out of the kiln. <b>Do not stand in the area of travel of the probe or probe carriage until the probe has reached its end position and the warning lamps go out.</b>
2	Wait until cooling-water temperature has dropped to 40 °C; you can monitor this on the controller: <b>Path:</b> Diagnosis ► Trends ► Cooling Water Return Temp.
3	Open the control cabinet.
4	Switch off the cooling-water pump -M51 at the motor breaker -F37 (1).  <p><b>Note:</b> You can also switch off the cooling-water pump at circuit breaker -F36 (2).</p>
5	Connect filling pipe to the cooling-water supply of the cooling module. If possible, the filling pipe should be filled with water before connecting it to the cooling module in order to prevent any additional air from entering the cooling-water circuit. Also, make sure (e.g. by rinsing beforehand) that no dirt is deposited in the filling pipe.
6	Unscrew cap and slowly open vent cock (red) so that air can escape. 

Step	Procedure
7	Open shut-off valve -J63 and allow cooling water to flow in slowly until bubble-free cooling water appears at the heat exchanger drain valve.
8	Close shut-off valve -J63.
9	Close vent cock on heat exchanger, screw on cap.
10	Open shut-off valve -J63 again slowly and observe cooling-water pressure display on the touchscreen. Fill cooling water to a pressure of 1-1.5 bar (1000-1500 hPa). <b>Note:</b> It is advisable for two people to do this job.
11	Switch the cooling-water pump -M51 on again at motor breaker -F37 or circuit breaker -F36.
12	Close control cabinet again.
13	Turn service switch back to <i>OFF</i> position and insert probe again using the controller. <b>WARNING!</b> Probe moves into the kiln. <b>Do not stand in the area of travel of the probe or probe carriage until the probe is completely inserted into the kiln and the warning lamps go out.</b>

## Pneumatic system: Replacing the compressed-air filter

Maintenance interval   ▪ yearly

### Safety measures

#### **▲WARNING**

Always take the following safety measures when performing this work:

- ▶ Wear the general protective equipment.
- ▶ Turn the service switch to *ON* and secure the service switch against unauthorized switching (with a padlock).
- ▶ Do not enter the danger area around the retractor until it is at standstill and the warning lamps and buzzer are off and the flap valve is closed.
- ▶ Do not perform the work until the gas sampling system has cooled down.
- ▶ When the warning lamps light up or the warning buzzer buzzes, leave the danger area around the probe retractor immediately as the probe is about to move at any moment.
- ▶ Press the EMERGENCY STOP switch immediately if anyone is still in the danger area around the retractor after the warning lamps light up or the warning buzzer buzzes.
- ▶ Avoid contact with lubricating oil.
- ▶ Wash any lubricating oil off the skin immediately with water and soap.
- ▶ If any lubricating oil gets in the eyes despite protective glasses, rinse them thoroughly under running water, holding the eyelids open.
- ▶ Observe instructions in the lubricating oil manufacturer's safety data sheet.
- ▶ Always keep the floor around the gas sampling system clean and dry.

Explanation of safety measures: *Safety regulations for maintenance work on page 156.*

### Requirements

The service switch is in the *ON* position; the gas sampling probe is retracted from the kiln (see *Operating the service switch* on page 159).

## Instructions

How to replace the compressed-air filter in the pneumatic box:

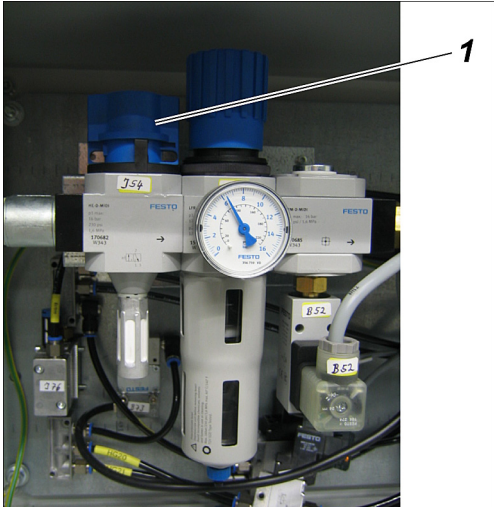
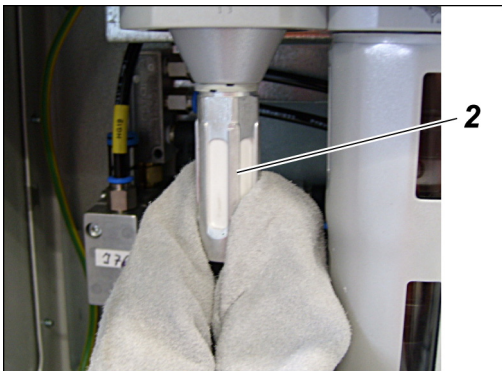
Step	Procedure
1	<p>Shut off compressed-air supply at gate valve -J54 (1) and wait until the manometer drops to 0 bar (0 hPa).</p> 
2	<p>Unscrew filter element (2) (in Figure: filter element on filter/pressure control combination -J53).</p> 
3	<p>Screw in new filter element hand-tight.</p>
4	<p>Perform steps 2 and 3 in the same way for pneumatic valves -J77, -J78 and -J79.</p>
5	<p>Open the compressed-air gate valve -J54 (1) again.</p>
6	<p>Turn service switch back to <i>OFF</i> position and insert probe again using the controller.</p> <p><b>WARNING!</b> Probe moves into the kiln. <b>Do not stand in the area of travel of the probe or probe carriage until the probe is completely inserted into the kiln and the warning lamps go out.</b></p>

<b>Topic</b>	<b>Page</b>
Errors and irregularities .....	214
Touchscreen error displays.....	216
Handling error messages .....	221

## Errors and irregularities

**Automatic processes** If an error occurs, the system triggers automatic processes to protect the gas sampling probe:

Phase	Description
1	The sampling system is switched to manual mode.
2	The gas sampling probe is retracted out of the kiln. <b>WARNING!</b> Probe movement. <b>Do not stand in the area of travel of the probe or probe carriage.</b> <b>Result:</b> Because the gas sampling probe is in manual mode, the gas sampling probe can no longer move in on its own.

**Note:** In the event of danger to personnel, you can interrupt these automatic processes by pressing the EMERGENCY-STOP switch.

### Irregularities and corrective action

The following table describes irregularities that may occur during operation of the gas sampling system and measures to be taken to remedy them:

Observation	Possible causes	Measures
Untypical running noise	<ul style="list-style-type: none"> <li>▪ Heat exchanger defective</li> <li>▪ Compressed-air motor defective</li> </ul>	<ul style="list-style-type: none"> <li>▪ Inform internal maintenance department or ABB Service</li> </ul>
Whistling noise from compressed-air system	<ul style="list-style-type: none"> <li>▪ Compressed-air system leak</li> </ul>	<ul style="list-style-type: none"> <li>▪ See <i>Checking for leaks</i> on page 171</li> </ul>
Probe travel is jerky	<ul style="list-style-type: none"> <li>▪ Probe carriage rails dirty</li> <li>▪ Wrong inclination of probe carriage</li> </ul>	<ul style="list-style-type: none"> <li>▪ Clean rails</li> <li>▪ Readjust probe carriage inclination using the adjustment screws, see <i>Probe retractor: Checking and, if necessary, adjusting the position of the probe</i> on page 198</li> </ul>
Probe not centered in kiln aperture	<ul style="list-style-type: none"> <li>▪ Incorrect probe alignment/positioning</li> </ul>	<ul style="list-style-type: none"> <li>▪ Realign probe</li> </ul>
Untypical or gurgling noises in the cooling-water circuit	<ul style="list-style-type: none"> <li>▪ Air bubbles in the cooling-water circuit</li> </ul>	<ul style="list-style-type: none"> <li>▪ Vent cooling-water circuit, see <i>Cooling module: Venting the cooling-water circuit</i> on page 206</li> <li>▪ Top up cooling water, see <i>Cooling module: Checking and topping up cooling water</i> on page 208</li> </ul>
Unusual probe movements (probe rocks up and down, sways to the sides, jerky travel)	<ul style="list-style-type: none"> <li>▪ Loose parts</li> <li>▪ Severe soiling of rails</li> </ul>	<ul style="list-style-type: none"> <li>▪ Have trained experts find out the cause</li> </ul>

<b>Observation</b>	<b>Possible causes</b>	<b>Measures</b>
Compressed-air hose bursts or compressed-air pipe cracks	<ul style="list-style-type: none"> <li>▪ Pressure controller defective</li> <li>▪ Incorrect pressure set on pressure controller</li> </ul>	<ul style="list-style-type: none"> <li>▪ Close gate valve in pneumatic box, then wait for all compressed-air to blow out completely before approaching</li> <li>▪ Shut down gas sampling system and secure against start-up until the cause has been fixed</li> </ul>
Cooling-water pipe bursts or cracks	<ul style="list-style-type: none"> <li>▪ Mechanical damage to the pipe from outside</li> </ul>	<ul style="list-style-type: none"> <li>▪ Wait until all cooling water has run out before approaching</li> <li>▪ Shut down gas sampling system and secure against start-up until the cause has been fixed</li> <li>▪ Do not begin repair work until it has cooled down</li> </ul>
Probe or heat exchanger cracks	<ul style="list-style-type: none"> <li>▪ Mechanical damage and thermal stress</li> </ul>	<ul style="list-style-type: none"> <li>▪ Wait until all cooling water has run out before approaching</li> <li>▪ Shut down gas sampling system and secure against start-up until the cause has been fixed</li> <li>▪ Do not begin repair work until it has cooled down</li> </ul>
Probe movement blocked	<ul style="list-style-type: none"> <li>▪ Mechanical damage</li> <li>▪ Incrustation</li> </ul>	<ul style="list-style-type: none"> <li>▪ Press EMERGENCY STOP switch before working on the probe</li> <li>▪ Remove blockage</li> </ul>

## Touchscreen error displays

**Error display** The touchscreen on the front of the control cabinet displays error messages. All error messages do not appear directly on the touchscreen's Start screen but are rather stored in the logbook (Message screen). Touch the **Message** button on the interface to display this logbook.

**Additional information** You can display additional information in order to identify errors in detail as follows:

Step	Procedure
1	Press the <b>Message</b> button on the touchscreen.
2	Select message using the scroll buttons.
3	Press <b>Help</b> button.
4	The touchscreen displays additional details. <b>Note:</b> Use the scroll buttons to view longer texts.

**Measures** The following table describes errors that may occur on the gas sampling system and measures to be taken to remedy them:

Error display	Plain text (not stored in controller)	Cause	Measures
Stör	Error	<ul style="list-style-type: none"> <li>▪ One or several pending error messages</li> </ul>	<ul style="list-style-type: none"> <li>▪ Rectify single error message</li> </ul>
Faulty Entry: —	Value input error	<ul style="list-style-type: none"> <li>▪ The value input is greater/less than the limits defined by the system</li> </ul>	<ul style="list-style-type: none"> <li>▪ Observe tolerance ranges when entering values, see <i>Default operating parameter settings</i> on page 50</li> </ul>
Emergency Stop Active	EMERGENCY STOP activated	<ul style="list-style-type: none"> <li>▪ The EMERGENCY-STOP switch was pressed</li> </ul>	<ul style="list-style-type: none"> <li>▪ Find reason for activating the EMERGENCY STOP</li> <li>▪ Remove danger</li> <li>▪ Unlock EMERGENCY-STOP switch</li> <li>▪ Press service switch</li> <li>▪ <b>WARNING!</b> Actuating the service switch moves the probe out of the kiln. <b>Do not stand in the area of travel of the probe or probe carriage.</b></li> </ul>
Protection Area OPEN	Protection area is not closed	<ul style="list-style-type: none"> <li>▪ Personnel protection area is not closed</li> </ul>	<ul style="list-style-type: none"> <li>▪ Close the protection area</li> <li>▪ Check switching contact</li> <li>▪ If the contact is not used, check the jumper</li> </ul>
Compressed Air Not OK	Central compressed-air supply input pressure too low	<ul style="list-style-type: none"> <li>▪ Central compressed-air supply disrupted</li> <li>▪ Pressure switch 577 error</li> </ul>	<ul style="list-style-type: none"> <li>▪ Check central compressed-air supply</li> <li>▪ Check functioning and setting of pressure switch 577</li> </ul>



<b>Error display</b>	<b>Plain text (not stored in controller)</b>	<b>Cause</b>	<b>Measures</b>
Error Compressed Air Emergency Tank	Minimum compressed-air emergency tank pressure not adequate	<ul style="list-style-type: none"> <li>▪ If the central compressed-air supply is also faulty, first remedy the cause for failure of the central compressed-air supply</li> <li>▪ Leak in tank supply pipes or tank itself</li> <li>▪ Pressure switch 578 error</li> </ul>	<ul style="list-style-type: none"> <li>▪ Check central compressed-air supply</li> <li>▪ Check supply pipe to compressed-air emergency tank for leaks</li> <li>▪ Check functioning and setting of pressure switch 578</li> </ul>
Sample Gas Probe Pressure MIN	Sample gas main alarm low pressure not reached	<ul style="list-style-type: none"> <li>▪ Gas sampling probe clogged</li> <li>▪ Sample gas line clogged</li> </ul>	<ul style="list-style-type: none"> <li>▪ Check and, if necessary, clean gas sampling probe</li> <li>▪ Check and, if necessary, clean sample gas line</li> </ul>
Probe Heating Temp. MIN	Probe heating temperature too low	<ul style="list-style-type: none"> <li>▪ At start-up probe heating not switched on long enough</li> <li>▪ Probe heating defective</li> <li>▪ Defect in temperature controller</li> <li>▪ Heating connection cable damaged</li> <li>▪ Heating sleeve defective</li> </ul>	<ul style="list-style-type: none"> <li>▪ Wait for heating-up time (approx. 20 min)</li> <li>▪ Check probe heating for proper functioning</li> </ul>
Probe Heating Temp. MAX	Probe heating temperature too high	<ul style="list-style-type: none"> <li>▪ Probe heating overheating</li> </ul>	<ul style="list-style-type: none"> <li>▪ Check PT100 sensor</li> </ul>
Probe Heating Temp. MIN	Probe heating temperature too low	<ul style="list-style-type: none"> <li>▪ At start-up probe heating not switched on long enough</li> <li>▪ Probe heating defective</li> <li>▪ Defect in temperature controller</li> <li>▪ Heating connection cable damaged</li> <li>▪ Heating sleeve defective</li> </ul>	<ul style="list-style-type: none"> <li>▪ Wait for heating-up time (approx. 20 min)</li> <li>▪ Check probe heating for proper functioning</li> </ul>
Cable Drag Chain Sample Gas Line Temp. Error	Cable drag chain sample gas line temp. error	<ul style="list-style-type: none"> <li>▪ Cable drag chain heating not switched on long enough</li> <li>▪ Cable drag chain heating defective</li> </ul>	<ul style="list-style-type: none"> <li>▪ Wait for heating-up time (approx. 20 min)</li> <li>▪ Check heating for proper functioning</li> </ul>
Error Position Switch Probe Action	Probe movement limit switch error	<ul style="list-style-type: none"> <li>▪ Front and at least one of the two rear limit switches for probe movement triggered simultaneously</li> </ul>	<ul style="list-style-type: none"> <li>▪ Check function and position of limit switches</li> <li>▪ Check position of trigger element</li> </ul>
Error 3x Cleaning Not Successful Probe H	Probe cleaning failed after 3x cleaning	<ul style="list-style-type: none"> <li>▪ Cleaning cycle can no longer clean probe H adequately</li> </ul>	<ul style="list-style-type: none"> <li>▪ Remove dirt sticking to the gas inlet</li> <li>▪ Clean the filter element</li> <li>▪ Check compressed-air supply and solenoid valves of probe cleaning system</li> </ul>
Error Position Switch Plunger Action	Plunger movement limit switch error	<ul style="list-style-type: none"> <li>▪ Both plunger movement limit switches triggered simultaneously</li> </ul>	<ul style="list-style-type: none"> <li>▪ Check function and position of limit switches</li> </ul>

<b>Error display</b>	<b>Plain text (not stored in controller)</b>	<b>Cause</b>	<b>Measures</b>
Error Plunger Out	Plunger failed to reach front end position after set control time	<ul style="list-style-type: none"> <li>▪ Plunger blocked</li> <li>▪ In connection with compressed air error: insufficient compressed-air supply</li> </ul>	<ul style="list-style-type: none"> <li>▪ Check central compressed-air supply</li> <li>▪ Check plunger for mechanical blocking and rectify as needed</li> <li>▪ Check compressed-air supply to pneumatic cylinder of probe H</li> </ul>
Error Plunger In	Plunger failed to reach rear end position after set control time	<ul style="list-style-type: none"> <li>▪ Plunger blocked</li> <li>▪ In connection with compressed air error: insufficient compressed-air supply</li> </ul>	<ul style="list-style-type: none"> <li>▪ Check central compressed-air supply</li> <li>▪ Check plunger for mechanical blocking and rectify as needed</li> <li>▪ Check compressed-air supply to pneumatic cylinder of probe H</li> </ul>
Error Probe H Blocked During Retraction	Probe movement blocked during retraction	<ul style="list-style-type: none"> <li>▪ Incrustation on probe tip</li> <li>▪ Duct opening clogged up</li> <li>▪ Retractor drive defect</li> <li>▪ Front limit switch error</li> </ul>	<ul style="list-style-type: none"> <li>▪ Check gas sampling probe for incrustation</li> <li>▪ Check and, if necessary, clean gas sampling probe entry zone</li> <li>▪ Check gas sampling probe travel time, modify speed setting if necessary</li> </ul>
Error Probe H Blocked During Insertion	Probe movement blocked during insertion	<ul style="list-style-type: none"> <li>▪ Incrustation on probe tip</li> <li>▪ Duct opening clogged up</li> <li>▪ Retractor drive defect</li> <li>▪ Shutter drive defect</li> <li>▪ Front limit switch error</li> </ul>	<ul style="list-style-type: none"> <li>▪ Check shutter functioning</li> <li>▪ Check drive and limit switch of shutter</li> <li>▪ Check gas sampling probe for incrustation</li> <li>▪ Check and, if necessary, clean gas sampling probe entry zone</li> <li>▪ Check gas sampling probe travel time, modify speed setting if necessary</li> </ul>
Error 3x Cleaning Not Successful Probe 60	Probe cleaning failed after 3x	<ul style="list-style-type: none"> <li>▪ Cleaning cycle can no longer clean probe 60S adequately</li> </ul>	<ul style="list-style-type: none"> <li>▪ Remove dirt sticking to the gas inlet</li> <li>▪ Clean the filter element</li> <li>▪ Check compressed-air supply and solenoid valves of probe cleaning system</li> </ul>
Error Probe 60 Blocked During Retraction	Probe movement blocked during retraction	<ul style="list-style-type: none"> <li>▪ Incrustation on probe tip</li> <li>▪ Duct opening clogged up</li> <li>▪ Retractor drive defect</li> <li>▪ Rear limit switch error</li> </ul>	<ul style="list-style-type: none"> <li>▪ Check gas sampling probe for incrustation</li> <li>▪ Check rear limit switch for proper functioning</li> <li>▪ Check and, if necessary, clean gas sampling probe entry zone</li> <li>▪ Check gas sampling probe travel time, modify speed setting if necessary</li> </ul>

<b>Error display</b>	<b>Plain text (not stored in controller)</b>	<b>Cause</b>	<b>Measures</b>
Error Probe 60 Blocked During Insertion	Probe movement blocked during insertion	<ul style="list-style-type: none"> <li>▪ Incrustation on probe tip</li> <li>▪ Duct opening clogged up</li> <li>▪ Retractor drive defect</li> <li>▪ Shutter drive defect</li> <li>▪ Front limit switch error</li> </ul>	<ul style="list-style-type: none"> <li>▪ Check gas sampling probe for incrustation</li> <li>▪ Check shutter functioning</li> <li>▪ Check drive and limit switch of shutter</li> <li>▪ Check and, if necessary, clean gas sampling probe entry zone</li> <li>▪ Check gas sampling probe travel time, modify speed setting if necessary</li> </ul>
C. Water Flow Temp. MAX	Cooling-water flow temperature main alarm high exceeded	<ul style="list-style-type: none"> <li>▪ Insufficient heat exchanger cooling output</li> </ul>	<ul style="list-style-type: none"> <li>▪ Check heat exchanger for soiling and, if necessary, clean</li> </ul>
C. Water Flow Temp. MIN	Cooling-water flow temperature too low	<ul style="list-style-type: none"> <li>▪ Cooling water not heated up enough</li> </ul>	<ul style="list-style-type: none"> <li>▪ With probe inserted, wait for heating-up time to finish</li> </ul>
C. Water Flow / Return Temp. Diff. MIN	Difference too small between cooling-water flow and return	<ul style="list-style-type: none"> <li>▪ Minor heat build-up on probe tip due to severe incrustation.</li> </ul>	<ul style="list-style-type: none"> <li>▪ Check gas sampling probe for incrustation and, if necessary, clean</li> </ul>
C. Water Flow Rate MIN	Cooling-water flow rate pre-alarm low not reached	<ul style="list-style-type: none"> <li>▪ Insufficient capacity of cooling-water pump</li> <li>▪ Cooling water temperature too low</li> <li>▪ Bent cooling-water tube</li> </ul>	<ul style="list-style-type: none"> <li>▪ Vent the cooling-water circuit</li> <li>▪ Check cooling-water level and, if necessary, top up</li> <li>▪ If necessary, replace pump</li> </ul>
C. Water Flow Rate MIN2	Cooling-water flow rate main alarm low not reached	<ul style="list-style-type: none"> <li>▪ Insufficient capacity of cooling-water pump</li> <li>▪ Cooling water temperature too low</li> <li>▪ Bent cooling-water tube</li> </ul>	<ul style="list-style-type: none"> <li>▪ Vent the cooling-water circuit</li> <li>▪ Check cooling-water level and, if necessary, top up</li> <li>▪ If necessary, replace pump</li> </ul>
C. Water Pressure MIN	Cooling-water pressure pre-alarm low not reached	<ul style="list-style-type: none"> <li>▪ Insufficient capacity of cooling-water pump</li> <li>▪ Cooling-water circuit leak</li> </ul>	<ul style="list-style-type: none"> <li>▪ Check cooling-water circuit for leaks, fix leaks, top up cooling water if necessary</li> <li>▪ Check delivery rate of cooling-water pump</li> </ul>
C. Water Pressure MIN2	Cooling-water pressure main alarm low not reached	<ul style="list-style-type: none"> <li>▪ Cooling-water circuit leak</li> <li>▪ Probe leak</li> <li>▪ Cooling-water pump leak</li> <li>▪ Insufficient capacity of cooling-water pump</li> </ul>	<ul style="list-style-type: none"> <li>▪ Check cooling-water circuit for leaks, fix leaks, top up cooling water if necessary</li> <li>▪ Check delivery rate of cooling-water pump</li> </ul>
C. Water Pressure MAX	Cooling-water pressure main alarm high exceeded	<ul style="list-style-type: none"> <li>▪ Cooling-water circuit filling pressure too high</li> </ul>	<ul style="list-style-type: none"> <li>▪ Ensure correct filling pressure</li> </ul>
Error C. Water Module	Centralized cooling module error message	<ul style="list-style-type: none"> <li>▪ Circuit breaker tripped</li> </ul>	<ul style="list-style-type: none"> <li>▪ Switch circuit breaker back on</li> <li>▪ If it trips again, locate and remedy cause</li> </ul>
CAN Error Slave 1	Can bus error to slave 1	<ul style="list-style-type: none"> <li>▪ Can bus connection error to slave 1 -D31</li> </ul>	<ul style="list-style-type: none"> <li>▪ Check CAN bus cable for damage</li> <li>▪ Contact ABB Service if necessary</li> </ul>

<b>Error display</b>	<b>Plain text (not stored in controller)</b>	<b>Cause</b>	<b>Measures</b>
CAN Error Slave 2	Can bus error to slave 2	<ul style="list-style-type: none"> <li>▪ Can bus connection error to slave 2 -D32</li> </ul>	<ul style="list-style-type: none"> <li>▪ Check CAN bus cable for damage</li> <li>▪ Contact ABB Service if necessary</li> </ul>
CAN Error Slave 3	Can bus error to slave 3	<ul style="list-style-type: none"> <li>▪ Can bus connection error to slave 3 -D33</li> </ul>	<ul style="list-style-type: none"> <li>▪ Check CAN bus cable for damage</li> <li>▪ Contact ABB Service if necessary</li> </ul>
CAN Error Slave 4	Can bus error to slave 4	<ul style="list-style-type: none"> <li>▪ Can bus connection error to slave 4 -D51</li> </ul>	<ul style="list-style-type: none"> <li>▪ Check CAN bus cable for damage</li> <li>▪ Contact ABB Service if necessary</li> </ul>
CAN Error Slave 5	Can bus error to slave 5	<ul style="list-style-type: none"> <li>▪ Can bus connection error to slave 5 -D71</li> </ul>	<ul style="list-style-type: none"> <li>▪ Check CAN bus cable for damage</li> <li>▪ Contact ABB Service if necessary</li> </ul>
CAN Error Slave 6	Can bus error to slave 6	<ul style="list-style-type: none"> <li>▪ Can bus connection error to slave 6 -D72</li> </ul>	<ul style="list-style-type: none"> <li>▪ Check CAN bus cable for damage</li> <li>▪ Contact ABB Service if necessary</li> </ul>
CAN Error Slave 7	Can bus error to slave 7	<ul style="list-style-type: none"> <li>▪ Can bus connection error to slave 7 -D73</li> </ul>	<ul style="list-style-type: none"> <li>▪ Check CAN bus cable for damage</li> <li>▪ Contact ABB Service if necessary</li> </ul>
CAN Error Slave 8	Can bus error to slave 8	<ul style="list-style-type: none"> <li>▪ Can bus connection error to slave 8 -K31</li> </ul>	<ul style="list-style-type: none"> <li>▪ Check CAN bus cable for damage</li> <li>▪ Contact ABB Service if necessary</li> </ul>
CAN Error Slave 9	Can bus error to slave 9	<ul style="list-style-type: none"> <li>▪ Can bus connection error to slave 9 -D74</li> </ul>	<ul style="list-style-type: none"> <li>▪ Check CAN bus cable for damage</li> <li>▪ Contact ABB Service if necessary</li> </ul>

# Handling error messages

## Safety measures

### **WARNING**

Always take the following safety measures when performing this work:

- ▶ Wear the general protective equipment.
- ▶ Before commencing any work on the gas sampling system, turn the service switch to *ON* and secure the service switch against unauthorized switching (with a padlock).
- ▶ Additionally press the EMERGENCY-STOP switch before working on the retractor or probe.
- ▶ Do not enter the danger area around the retractor until it is at standstill and the warning lamps and buzzer are off.
- ▶ Never stand in the danger area around the retractor when the protective installation is closed.
- ▶ When the warning lamps light up or the warning buzzer buzzes, leave the danger area around the probe retractor immediately as the probe is about to move at any moment.
- ▶ Press the EMERGENCY-STOP switch immediately if anyone is still in the danger area around the retractor after the warning lamps light up or the warning buzzer buzzes.

Explanation of safety measures: *Safety regulations for maintenance work on page 156.*

## Requirements

In the event of an error, the probe is automatically retracted out of the kiln until the probe reaches its end position. To make sure that it really has reached its end position and that no unexpected probe movement can be expected, wait for the warning lamps on the retractor terminal box to go out before fixing the errors.

## Instructions

Proceed as follows to fix errors:

Step	Procedure
1	Turn service switch to <i>ON</i> position. When working on the retractor and gas sampling probe, additionally actuate the EMERGENCY-STOP switch for reasons of safety.
2	Fix errors. <b>DANGER!</b> Fixing errors requires special training and involves working on the open and powered-on gas sampling system. Therefore this may only be carried out by qualified and specially trained personnel.
3	Turn service switch to <i>OFF</i> position.
4	In controller: insert the probe. <b>Path:</b> Operation ▶ Probe ▶ Probe Action ▶ Insert <b>WARNING!</b> The probe moves into the kiln. <b>Do not stand in the area of travel of the probe or probe carriage.</b>
5	In controller: switch gas sampling system to Automatic mode. <b>Path:</b> Operation ▶ Automatic on / off



<b>Topic</b>	<b>Page</b>
Shutting down the system .....	224
Disassembling the system.....	227
Storing the system .....	229
Putting the system back into operation .....	230
Disposing of the system .....	231

## Shutting down the system

**Meaning** These instructions describe how to shut down the gas sampling probe. Note that the cooling water should only be drained if the system is shut down for prolonged periods or if it is subsequently disassembled. Otherwise the cooling water can stay in the system.

**Mechanical, thermal and material dangers**

### **WARNING**

**Risk of injury in the area of the gas sampling system due to moving or falling parts, hot surfaces, hot cooling water, anti-freeze, compressed air, lubricating oil**

Wear general personal protective equipment:

- ▶ Closed overalls with long trousers and long sleeves
- ▶ Safety shoes
- ▶ Safety gloves suitable for mechanical work
- ▶ Safety glasses
- ▶ Protective helmet
- ▶ If necessary, additional protective equipment if prescribed by the operator.

**Hot surfaces**

### **WARNING**

**danger of burning due to hot surfaces during and after operation of the gas sampling system.**

- ▶ Do not touch the gas sampling system during and after operation.
- ▶ Do not touch the gas sampling system until it has cooled down to 50 °C. Specifically, do not touch
  - the cooling module,
  - the heated sample gas line,
  - the connection box for the heated sample gas line on the retractor,
  - the heated sampling filter,
  - the entire gas sampling probe,
  - the metal structure of the retractor,
  - the shutter of the duct opening.
- ▶ If it is unavoidable to touch hot components, wear a face mask against heat, heat-proof gloves and protective welder's clothing.

**Harmful anti-freeze**

### **CAUTION**

**Danger of injury to skin and eyes in the event of contact with cooling water or anti-freeze.**

- ▶ Avoid contact with the cooling water and the anti-freeze.
- ▶ Wash any cooling water and anti-freeze off the skin immediately with water and soap.
- ▶ If cooling water or anti-freeze gets in the eyes despite protective glasses, rinse them thoroughly under running water, holding the eyelids open.
- ▶ Observe instructions in the anti-freeze manufacturer's safety data sheet.

**Requirements**

The following conditions must be met:

- The system is switched off at the main switch.



- Central compressed-air supply shut off, gate valve in pneumatic box closed (compressed-air pipes are vented).
- Rotary kiln is shut down.
- The system has cooled down.

**Instructions: Shutting down** Perform the following steps to shut down the system:

Step	Procedure
1	Secure the closed shutter on the duct flange with the enclosed locking device.
2	Unscrew sample gas line screw connection on the analyzer cabinet and gas sampling probe.
3	Flush sample gas line, filter unit and sample gas probe with dry, dust-free and oil-free instrument air (flow rate approx. 100 l/h) for about 15 minutes.
4	Clean any residue and incrustations off the filter unit and probe pipe. <b>Note:</b> Only clean mechanically. Do not use chemicals (particularly acids and lyes) for cleaning.

**Instructions: Draining cooling water** Proceed as follows to drain the cooling water:

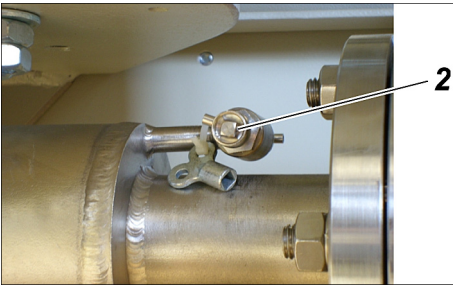
Step	Procedure
1	Unscrew cap and slowly open vent cock <b>(1)</b> so that air can escape. 
2	Open drain valves <b>(2)</b> on probe pipe. 
3	Detach cooling-water tubes from screw connectors on the cooling module and allow cooling water to drain. Empty any remaining water in the cooling-water tubes. If anti-freeze (Glykol) was admixed, observe disposal regulations in accordance with national legislation.

**Further procedure** Refer to *Disassembling the system* on page 227 for details on further procedure.

## Disassembling the system

### Mechanical, thermal and material dangers

#### **WARNING**

**Risk of injury in the area of the gas sampling system due to moving or falling parts, hot surfaces, hot cooling water, anti-freeze, compressed air, lubricating oil**

Wear general personal protective equipment:

- ▶ Closed overalls with long trousers and long sleeves
- ▶ Safety shoes
- ▶ Safety gloves suitable for mechanical work
- ▶ Safety glasses
- ▶ Protective helmet
- ▶ If necessary, additional protective equipment if prescribed by the operator.

### Heavy transport units

#### **WARNING**

**Danger of crushing when lifting or lowering the transport unit**

- ▶ Only appropriately trained personnel may transport the transport units and only with the aid of the recommended transport equipment.
- ▶ Do not stand under suspended loads.
- ▶ Follow the transport instructions in these operating instructions carefully.

### Hot surfaces, hot gases, jet flames

#### **WARNING**

**Risk of burning due to jet flames and hot gases at the uncovered duct opening when the rotary kiln is in operation**

- ▶ Preferably install or remove the probe when the rotary kiln is out of operation.
- ▶ If you install or remove the probe when the rotary kiln is in operation:
  - Wear a face mask against heat, heat-proof gloves and protective welder's clothing and respiratory protection against toxic gases.
- ▶ Keep the time in which the duct opening is open as short as possible.

### Harmful dusts

#### **CAUTION**

**Danger due to harmful dusts when cleaning the gas sampling system**

- ▶ Wear a dust mask when cleaning.
- ▶ Wash any dust off the skin immediately with water and soap.

### Slippery floor

#### **CAUTION**

**Risk of falling on slippery floor due to escaped or spilled cooling water and lubricating oil or dirt**

- ▶ Always keep the floor around the gas sampling system clean and dry.

### Requirements

The following conditions must be met to disassemble the system:

- System must have been properly shut down (see *Shutting down the system* on page 224).
- Cooling water must be drained (see *Shutting down the system* on page 224).
- Probe retractor powered off and unpressurized (by trained personnel).

## Instructions

How to disassemble the gas sampling system:

Step	Procedure
1	Clean the whole system roughly with compressed air and/or brush.
2	Remove oil from compressed-air oiler and dispose of it in accordance with national regulations. <b>Note:</b> Observe safety and disposal regulations for the particular oil.
3	Label all connection lines to prevent confusion.
4	Detach connection lines.
5	Unscrew fastening screws on cooling module and control cabinet and transport modules away. Perform the same steps for the transformer and compressed-air tank (if present).
6	Suspend probe retractor at its attachment points using suitable lifting gear. <b>Note:</b> Pay particular attention to suitable fastening points for the lifting equipment on the system. Observe relevant local regulations.
7	Unscrew and remove fastening screws on mounting flange and attachment points.
8	Using lifting gear, lower probe retractor until you can screw on the enclosed transport supports.
9	Place probe retractor on ground and secure from falling over.

## Further procedure

The following table shows further procedure:

If the system ...	follow the following instructions:
is to be stored for a prolonged period	<i>Storing the system</i> on page 229.
is to be disposed of	<i>Disposing of the system</i> on page 231.
is to be relocated	<i>Transporting the system in the company</i> on page 87.
is to be unpacked and transported to another place	<ul style="list-style-type: none"> <li>▪ Do not transport the probe retractor without transport supports.</li> <li>▪ Use adequately load-bearing and rigid pallets.</li> <li>▪ Use suitably sized transport crates for longer-distance transports.</li> <li>▪ Fasten sampling probe firmly on retractor if it is not being demounted.</li> </ul> <p><b>Note:</b> The retractor must not be transported by fork-lift truck without suitable additional transport packaging.</p>
is to be put back into operation	<i>Start-up</i> on page 111.

## Storing the system

### General storage information

Store in a place protected from the weather. Observe the designated storage temperatures and humidities. The transport packing, if present, should not be removed during storage. In the event that the gas sampling system is temporarily shut down, ensure suitable wrapping.

### Storing the various modules

Observe the following instructions with regard to storing the various modules:

Module	Storage conditions
Retractor including probe	<ul style="list-style-type: none"> <li>▪ During storage, support the tip of the assembled gas sampling probe.</li> <li>▪ Only store after draining all water.</li> </ul>
Cooling module	<ul style="list-style-type: none"> <li>▪ Only store after draining all water.</li> </ul>
Control cabinet	<ul style="list-style-type: none"> <li>▪ Store on rear side lying on pallet</li> </ul>
Transformer (optional)	<ul style="list-style-type: none"> <li>▪ Store on pallet</li> <li>▪ Ensure storage in a dry area (no condensation!).</li> </ul>
Compressed-air tank (optional)	<ul style="list-style-type: none"> <li>▪ Ensure adequate protection of the attachments.</li> <li>▪ Only store after draining all water.</li> </ul>

### Environmental conditions

Observe the following physical limits with regard to storing the various modules:

Module	Environmental conditions for storage
Retractor including probe	<p><b>Ambient temperature:</b> +5 °C to +55 °C; after completely draining all water and drying parts in contact with cooling water or condensation: -20 °C to +55 °C</p> <p><b>Air humidity:</b> Year-round average max. 75 %, short-term max. 95 %, occasional slight condensation is permitted</p>
Cooling module	<p><b>Ambient temperature:</b> +5 °C to +55 °C; after completely draining all water and drying parts in contact with cooling water or condensation: -20 °C to +55 °C</p> <p><b>Air humidity:</b> Year-round average max. 75 %, short-term max. 95 %, occasional slight condensation is permitted</p>
Control cabinet	<p><b>Ambient temperature:</b> -20 °C to +55 °C</p> <p><b>Air humidity:</b> Year-round average max. 75 %, short-term max. 95 %, occasional slight condensation is permitted</p>
Transformer (optional)	<p><b>Ambient temperature:</b> -25 °C to +55 °C</p> <p><b>Air humidity:</b> Year-round average max. 80 %, short-term max. 95 %, without condensation</p>
Compressed-air tank (optional)	<p><b>Ambient temperature:</b> +5 °C to +55 °C; after completely draining all water and drying parts in contact with cooling water or condensation: -20 °C to +55 °C</p> <p><b>Air humidity:</b> Year-round average max. 75 %, short-term max. 95 %, occasional slight condensation is permitted</p>

## Putting the system back into operation

### Instructions

Follow the instructions given in *Start-up* on page 111 to put the system back into operation.

## Disposing of the system

### Harmful anti-freeze

#### CAUTION

#### **Danger of injury to skin and eyes in the event of contact with cooling water or anti-freeze**

- ▶ Avoid contact with the cooling water and the anti-freeze.
- ▶ Wash any cooling water and anti-freeze off the skin immediately with water and soap.
- ▶ If cooling water or anti-freeze gets in the eyes despite protective glasses, rinse them thoroughly under running water, holding the eyelids open.
- ▶ Observe instructions in the anti-freeze manufacturer's safety data sheet.

### Harmful lubricating oil

#### CAUTION

#### **Danger due to skin and eye injuries in the event of contact with lubricating oil from the pneumatic box of, from the filter muffler or from inside the pneumatic motor**

- ▶ Avoid contact with lubricating oil.
- ▶ Wash any lubricating oil off the skin immediately with water and soap.
- ▶ If any lubricating oil gets in the eyes despite protective glasses, rinse them thoroughly under running water, holding the eyelids open.
- ▶ Observe instructions in the lubricating oil manufacturer's safety data sheet.

### Requirements

The following conditions must be met:

- System was properly shut down and disassembled (see *Shutting down the system* on page 224, *Disassembling the system* on page 227).

### Disposal rules

- Drain oil from compressed-air oiler and dispose of it in accordance with national regulations.  
**Note:** Observe safety and disposal regulations for the particular oil.
- Drain cooling water from the cooling module.  
**Note:** If anti-freeze (Glykol) was admixed, observe disposal regulations in accordance with national legislation.
- Remove filter elements out of the gas sampling probe.  
**Note:** Contamination with filter dust can be expected. The safety and disposal regulations apply that also apply to handling and disposal of other filter dusts at the cement works.
- All other components of the gas sampling system must be disposed of expertly and in accordance with national legislation.





<b>Topic</b>	<b>Page</b>
Pneumatic/hydraulic interface plan.....	234
Electrical connection plan.....	236
Transformer connection plan.....	238

# Pneumatic/hydraulic interface plan

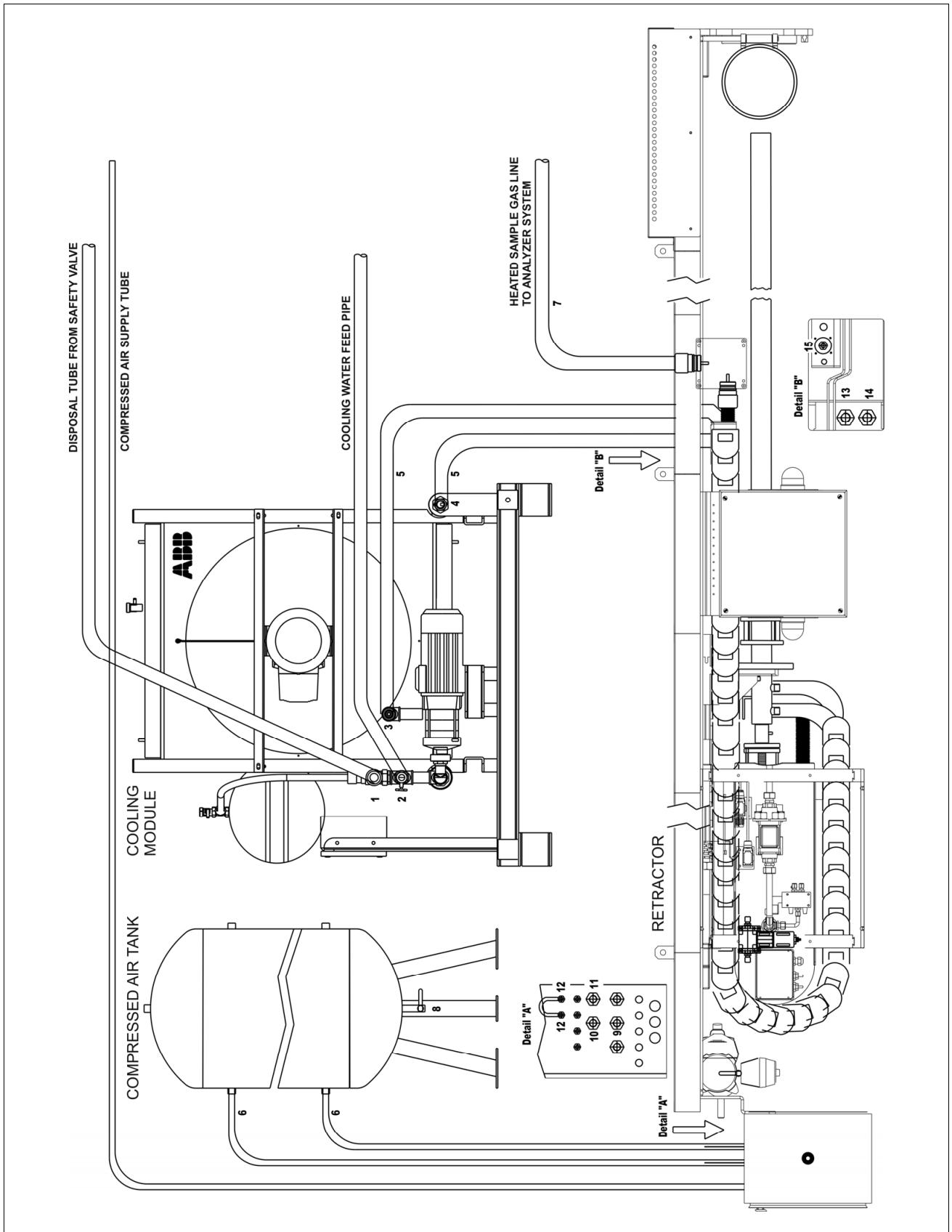

## Pneumatik-/Hydraulikverbindungen - Legende PNEUMATIC/HYDRAULIC CONNECTIONS - LEGEND

1	Sicherheitsventil Ausgang Schottverschraubung Ms mit Rohranschluß 1"	SAFETY RELIEF VALVE OUTLET BULKHEAD UNION BRASS WITH PIPE CONNECTOR 1"
2	Kühlwasser Eingang Schottverschraubung Ms mit Rohranschluß 1"	COOLING WATER INLET BULKHEAD UNION BRASS WITH PIPE CONNECTOR 1"
3	Kühlwasser Vorlauf Schottverschraubung Ms mit Rohranschluß 1"	COOLING WATER FEED BULKHEAD UNION BRASS WITH PIPE CONNECTOR 1"
4	Kühlwasser Rücklauf Schottverschraubung Ms mit Rohranschluß 1"	COOLING WATER RETURN BULKHEAD UNION BRASS WITH PIPE CONNECTOR 1"
5	Kühlwasserschlauch 25/39x7 mm 30m im Lieferumfang enthalten	COOLING WATER TUBE 25/39x7 mm 30m INCL. IN DELIVERY
6	Druckluftschlauch PA 18/14x2 mm 25m im Lieferumfang enthalten	PRESSURE AIR TUBE PA 18/14x2 mm 25m INCL. IN DELIVERY
7	Beh. Messgasleitung TBL-01 mit PTFE-Seele 4/6x1 mm	HEATED SAMPLE GAS LINE TBL-01 WITH PTFE BORE 4/6x1 mm
8	Kondensatablass	CONDENSATE OUTLET
9	Schottverschraubung "Druckluft zum Tank" für Schlauch 18/14 mm	BULKHEAD UNION "PRESSURE AIR TO TANK" FOR TUBE 18/14 mm
10	Schottverschraubung "Druckluft vom Tank" für Schlauch 18/14 mm	BULKHEAD UNION "PRESSURE AIR FROM TANK" FOR TUBE 18/14 mm
11	Schottverschraubung "Druckluft Eingang" für Schlauch 18/14 mm	BULKHEAD UNION "PRESSURE AIR INLET" FOR TUBE 18/14 mm
12	Schottverschraubungen "Externer pneumat. NOT-HALT" für Schlauch 6/4 mm (bei Anschluß eines ext. NOT-HALT-Schalters Schlauchbrücke entfernen!)	BULKHEAD UNION "EXTERNAL PNEUMATIC EMERGENCY STOP" FOR TUBE 6/4 mm (AT CONNECTING AN EXT. EMERGENCY STOP SWITCH REMOVE TUBE BRIDGE!)
13	Winkelverschraubung mit Rohrstutzen 1" "Kühlwasser Vorlauf"	ELBOW UNION WITH PIPE CONNECTOR 1" "COOLING WATER FEED"
14	Winkelverschraubung mit Rohrstutzen 1" "Kühlwasser Rücklauf"	ELBOW UNION WITH PIPE CONNECTOR 1" "COOLING WATER RETURN"
15	Anschluss für Messgasleitung TBL-01 mit VA-Flansch "Messgasausgang"	CONNECTOR FOR SAMPLE GAS LINE TBL-01 WITH SS-FLANGE "SAMPLE GAS OUTLET"



## elektrische Verbindungen - Legende ELECTRICAL CONNECTIONS - LEGEND

-D30	WINBLoc CAN-Brücke	WINBLoc CAN BRIDGE	-W35	Profibuskabel	PROFIBUS CABLE
-D50	WINBLoc CAN-Brücke	WINBLoc CAN BRIDGE		AWG22/1, d=0,64mm	AWG22/1, d=0,64mm
-D70	WINBLoc CAN-Brücke	WINBLoc CAN BRIDGE		(OPTION "PROFIBUS DP")	(OPTION "PROFIBUS DP")
-E71	Heizung Filtereinrichtung PFE3 (OPTION "60S")	HEATER FILTER UNIT PFE3 (OPTION "60S")	-W37	Signalkabel	SIGNAL CABLE
-E72	Heizer Gasentnahmesonde H (OPTION "H")	HEATER GAS SAMPLE PROBE H (OPTION "H")	-W38	Signalkabel	SIGNAL CABLE
-E73	Heizer Gasentnahmesonde H (OPTION "H")	HEATER GAS SAMPLE PROBE H (OPTION "H")	-W39	Signalkabel	SIGNAL CABLE
-M51	Kühlwasserpumpe	COOLING WATER PUMP		LiYY 2x0,5mm2 oder 2xAWG22	LiYY 2x0,5mm2 OR 2xAWG22
-M52	Lüftermotor Wärmetauscher	FAN MOTOR HEAT EXCHANGER		LiYY 2x0,5mm2 oder 2xAWG22	LiYY 2x0,5mm2 OR 2xAWG22
			-W50	Systembuskabel CAN open	SYSTEM BUS CABLE CANopen
				LiYCY 3x0,25mm2	LiYCY 3x2,5mm2
				(im Lieferumfang 15m)	(SCOPE OF DELIVERY 15m)
			-W51	Anschlußkasten Kühlmodul	TERMINAL BOX COOLING MODULE
-W30	Modbuskabel zum Analysen- system ACX, LiYCY 3x0,25mm2 (OPTION "ACX")	MODBUS CABLE TO ANALYSIS SYSTEM ACX, LiYCY 3x0,25mm2 (OPTION "ACX")	-W52	24VDC-Leitung	24VDC-CABLE
-W31	Steuerschrank	CONTROL CABINET		2x1,0mm2 oder 2xAWG18	2x1,0mm2 OR 2xAWG18
			-W53	Kabel 230/400 VAC	CABLE 230/400 VAC
				zur Kühlwasserpumpe	TO COOLING WATER PUMP
				5G1,5mm2 oder 5xAWG14	5G1,5mm2 OR 5xAWG14
-W32	Einspeisekabel 230/400 VAC 5G4mm2 oder 5xAWG10	POWER SUPPLY CABLE 230/400 VAC 5G4mm2 OR 5xAWG10	-W54	Kabel 230/400 VAC	CABLE 230/400 VAC
				zum Lüftermotor Wärmetauscher	TO FAN MOTOR HEAT EXCHANGER
				5G1,5mm2 oder 5xAWG14 mit Schirm	5x2,5mm2 OR 5xAWG14 WITH SHIELD
-W33	USV-Einspeisekabel 230 VAC 3G2,5mm2 oder 3xAWG12 (OPTION "UPS")	UPS POWER SUPPLY CABLE 230 VAC 3G2,5mm2 OR 3xAWG12 (OPTION "UPS")	-W70	Systembuskabel CAN open	SYSTEM BUS CABLE CANopen
-W34	Profibuskabel	PROFIBUS CABLE		LiYCY 3x0,25mm2	LiYCY 3x2,5mm2
	AWG22/1, d=0,64mm	AWG22/1, d=0,64mm		(im Lieferumfang 15m)	(SCOPE OF DELIVERY 15m)
	(OPTION "PROFIBUS DP")	(OPTION "PROFIBUS DP")	-W71	Anschlußkasten Fahrvorrichtung	TERMINAL BOX RETRACTOR
			-W72	24VDC-Leitung	24VDC-CABLE
				2x1,0mm2 oder 2xAWG18	2x1,0mm2 OR 2xAWG18
			-W73	24/26/28/30 VAC-Leitung	24/26/28/30 VAC-CABLE
				4x2,5mm2 oder 4xAWG14	4x2,5mm2 OR 4xAWG14
				(OPTION "H")	(OPTION "H")
			-W74	Kabel 230 VAC	CABLE 230 VAC
				zur Heizung der Filtereinrichtung	TO HEATER OF THE FILTER UNIT
				3G1,5mm2 oder 3xAWG14	3G1,5mm2 OR 3xAWG14
				(OPTION "60S")	(OPTION "60S")
			-W75	Kabel 230 VAC	CABLE 230 VAC
				zur Fahrvorrichtung	TO RETRACTOR UNIT
				3G1,5mm2 oder 3xAWG14	3G1,5mm2 OR 3xAWG14

# Transformer connection plan

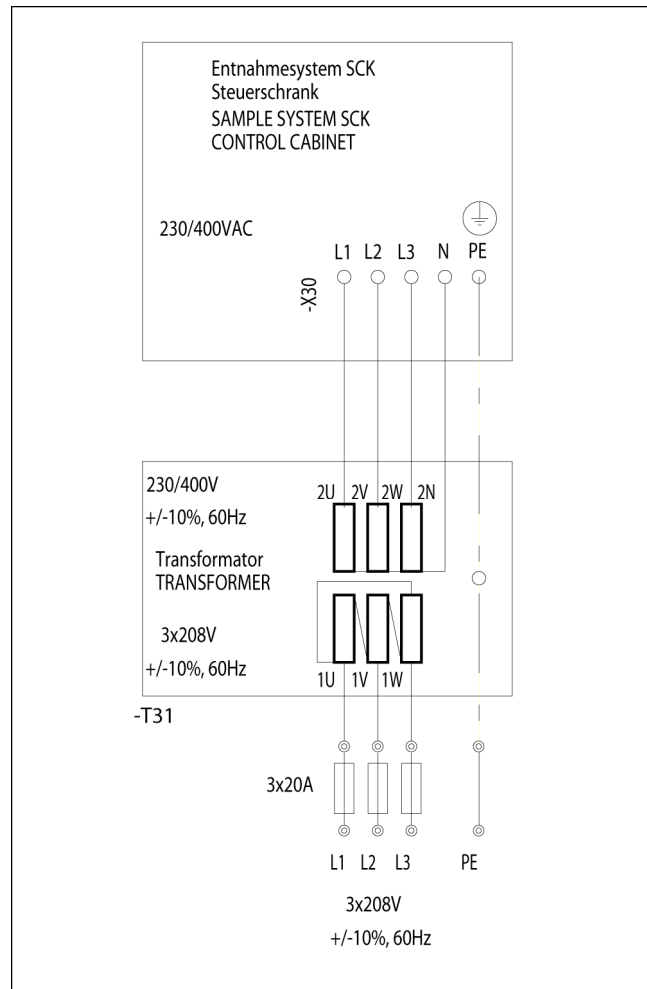

---

**A**

---

About these operating instructions • 8  
Access permissions • 49  
Acquiring spare parts and wear parts • 155  
Activation • 118  
After switching on  
    working on the cooling module • 121  
Anti-freeze • 114  
Appendix • 233

---

**B**

---

Basic safety rules • 56

---

**C**

---

Checking for leaks • 171  
Checking general condition • 140  
Checking protective installations • 167  
Checking site conditions • 93  
Checking the condition of the system, cleaning the system • 161  
Checking the pneumatic system • 123  
Checking the residual current circuit breaker • 165  
Checking/correcting operating parameters • 127  
Checks to perform when using probe H • 128  
Cleaning gas sampling probe 60S • 144  
Cleaning gas sampling probe H • 142  
Cleaning procedures  
    Probe 60S • 30, 144  
    Probe H • 28, 142  
Compressed-air tank and pneumatic system • 35  
Connecting external electric cables • 107  
Connecting internal electric cables • 105  
Connecting the sample gas line to the retractor • 104  
Controls and displays • 24  
Cooling module • 32  
    Checking and topping up cooling water • 208  
    Vent the cooling-water circuit • 206

---

---

**D**

---

Default operating parameter settings • 50  
Description of control system • 37  
Description of the sampling system • 17  
Dimensions and weights • 18  
Disassembling the system • 227  
Disposal • 231  
Disposing of the system • 231

---

**E**

---

Electrical connection plan • 236  
Emergency Stop • 146  
Equipment layout plan • 152  
Error message display • 48  
Errors • 213  
Errors and irregularities • 214  
Evaluating trend displays • 164

---

**G**

---

Gas sampling probe 60S • 30  
    Cleaning or replacing the outlet filter • 184  
    Removing incrustations • 182  
    Replacing the seal set • 187  
Gas sampling probe H • 28  
    Removing incrustations • 174  
    Replacing membrane pump membranes • 179  
    Replacing the intake filter • 176  
General • 7  
General transport information • 84

---

**H**

---

Handling error messages • 221

---

**I**

---

Inserting the probe and switching to automatic mode • 131  
Installation • 91  
Installation check • 113

---

Installing the compressed-air supply • 99  
Installing the control cabinet • 98  
Installing the cooling module • 101  
Installing the cooling water circuit • 103  
Installing the probe retractor • 95  
Intended conditions of use • 19

---

## **L**

---

Lubricating oil • 116

---

## **M**

---

Maintenance • 147  
Maintenance mode • 159  
Maintenance plan • 148  
Minimum compressed-air requirements • 35  
Mode of functioning and operating modes • 21  
Modes • 21  
Monitoring automatic mode • 138

---

## **N**

---

Nameplate • 12

---

## **O**

---

Operating parameters  
    Basic parameters • 50, 53  
    Limit parameters • 50, 53  
    Time parameters • 50, 53  
Operating the service switch • 159  
Operation • 135  
Optimizing operating parameters • 53  
Overview  
    installation • 92  
    Start-up • 112  
Overview of dangers • 58

---

## **P**

---

Personal safety equipment • 67  
Pneumatic system  
    Replacing the compressed-air filter • 211  
Pneumatic/hydraulic interface plan • 234  
Preparing the compressed-air supply • 116  
Preparing the cooling-water circuit • 114

---

Probe retractor • 26  
    Checking and replacing the filter muffler • 191  
    Checking and tightening the drive chain • 196  
    Checking and topping up the oiler • 193  
    Checking and, if necessary, adjusting the position indicator (probe end position) • 202  
    Checking and, if necessary, adjusting the position of the probe • 198  
    Checking filter/pressure control combination • 189  
    Checking the bellows • 205  
Process monitoring • 22  
Protective installations • 60  
Putting back into operation • 230  
Putting the system back into operation • 230

---

## **R**

---

Requirements to be met by personnel, work places • 65

---

## **S**

---

Safety • 55  
Safety instructions in this document • 10  
Safety measures  
    Installation • 69  
    Maintenance and troubleshooting • 78  
    Operation • 75  
    Start-up • 72  
    Transport and unpacking • 68  
Safety regulations for maintenance work • 156  
Safety regulations for operation • 136  
Scope of delivery • 90  
Service • 15  
Shutting down the system • 224  
Shutting down, storing, putting back into operation, disposal • 223  
Starting frequency converter and adapting control parameters • 124  
Start-up • 111  
Storing the system • 229  
Structure and function • 20  
Structure and function of the control system • 38  
System identification • 12

---



---

## T

---

Technical data • 18  
Tolerance ranges, tolerances • 50  
Touchpanel • 24, 37, 38, 49  
Touchscreen error displays • 216  
Transformer • 34  
Transformer connection plan • 238  
Transport and unpacking • 83  
Transport supports • 26, 87  
Transport the system in the company • 87

---

## U

---

Unpacking the system • 89  
User interface  
    Message screen • 44  
    Operation screen • 40  
    Parameter screen • 46  
    Trend screen • 42  
Using the EMERGENCY-STOP switch • 146

---

## W

---

Warning signs on the system • 63  
Work places • 65





---

ABB has Sales & Customer Support expertise  
in over 100 countries worldwide.

**[www.abb.com](http://www.abb.com)**



**ABB Automation GmbH**

Analytical  
Stierstaedter Strasse 5  
60488 Frankfurt am Main  
Germany  
Fax: +49 69 7930-4566  
E-mail: [cga@de.abb.com](mailto:cga@de.abb.com)

The Company's policy is one of continuous product  
improvement and the right is reserved to modify  
the information contained herein without notice.

Printed in the Fed. Rep. of Germany (11.16)

© ABB 2016