

# AUTO-purge III



*Proven solutions for a tough industry*

**Air Monitor**  
Precision Airflow Measurement  
An ONICON Brand

# AUTO-purge III

## Product Description

Air Monitor's AUTO-purge III is designed for applications where the continuous exposure to airborne particulate might impair the measurement accuracy of Air Monitor's Combustion Air (CA) Station or VOLU-probe/SS array. When activated by an Air Monitor "smart" flow transmitter (such as the VELTRON II, MASS-tron II or VELTRON DPT-*plus*) or a distributed control system, a combination of valves are

operated to introduce high pressure/high volume air to the flow measurement device's sensing ports for a short duration while simultaneously isolating the transmitter from over-pressurization. This periodic purging assists in maintaining the sensing ports of the total and static pressure manifolds in a clear, unobstructed condition.

## Standard Construction

### Brass and Copper Construction

- All wetted tubing, fittings, and valves constructed of copper and/or brass.
- Enclosure is NEMA 4 painted steel.
- External connection fittings are stainless steel FPT.

### Stainless Steel Construction

- All wetted tubing, fittings, and valves constructed of 316 stainless steel.
- Enclosure is NEMA 4 painted steel.
- External connection fittings are stainless steel FPT.

## Optional Construction

- NEMA 4X Stainless Steel Enclosure
- Vortex Cooler. Requires 80-100 psi air supply
- Enclosure Heater. Requires 120VAC power supply
- Viewing Window

### Power

- 24VAC
- 24VDC
- 120VAC

### Capacity

- Standard
- Low – Model SP
- High – Model HP

## Dimensional Specifications

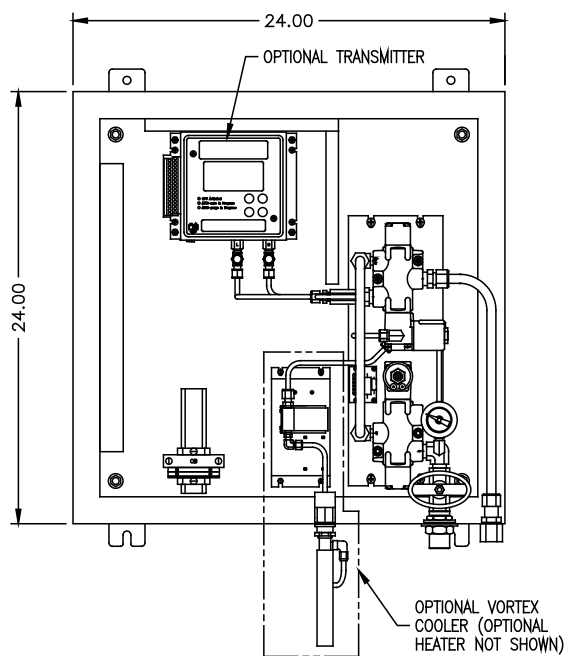

FRONT INTERIOR VIEW

### CONNECTION CODE

A. STATIC PRESSURE (LO) SIGNAL FROM FLOW ELEMENT	1/2" (F)NPT
B. TOTAL PRESSURE (HI) SIGNAL FROM FLOW ELEMENT	1/2" (F)NPT
C. SUPPLY AIR 80 - 125 PSIG	1/2" (F)NPT
F. OPTIONAL VORTEX COOLER MOUNTING HOLE	N/A
G. OPTIONAL VORTEX COOLER AIR SUPPLY	N/A
H. ELECTRICAL CONNECTION POWER WIRING	1/2" CONDUIT SEAL
J. ELECTRICAL CONNECTION SIGNAL WIRING	1/2" CONDUIT SEAL

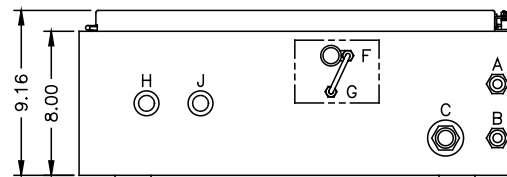

BOTTOM VIEW

# AUTO-purge III



The **VELTRON II** ultra-low differential pressure and flow “smart” transmitter, with its 0.1% of Natural Span accuracy, is intended for the most critical and demanding industrial applications that require the utmost accuracy and long-term stability. The VELTRON II’s long list of features include: AUTO-purge management; microprocessor based configuration and calibration; four lines of process data display via the graphical LCD; four analog outputs individually configurable for 0-10VDC or 4-20mA; AUTO-zero capability; electronic re-spanning; adjustable digital low pass filter; membrane keypad interface; 10:1 turndown capability; and nine different standard and bi-polar natural spans covering a range of 25.0 to 0.05 Inches w.c.



Via the addition of process temperature and pressure compensation, the ultra high accuracy VELTRON II becomes the MASS-tron II multi-variable flow transmitter. For process temperature the input is an analog signal from a remote 4-wire or loop powered temperature transmitter with the MASS-tron II having the capability of performing the linearization. The process pressure is measured by means of an internal absolute pressure transducer connected to the transmitter’s static pressure signal input.

The **VELTRON DPT-plus** transmitter combines most of the features and capability of the VELTRON II in a rugged, corrosion resistant NEMA 4X enclosure with standard industrial process connections that is Factory Mutual approved for hazardous locations – Explosion Proof for Class 1, Division 1, Groups B, C & D, and Dust Ignition Proof for Class II & III, Division I, Groups E, F & G. Other features include process temperature compensation, 3-line graphical LCD for display of process data, and dual 4-20mA isolated or non-isolated process outputs.

## Sequence of Operation

Automatic purging at regular field selectable intervals utilizes short duration, high pressure (up to 125 psig) air to maintain signal lines and the sensing ports of the total and static pressure manifolds in a clean, unobstructed condition. If accompanied with a VELTRON II, MASS-tron II or VELTRON DPT-plus transmitter, the last transmitted process outputs are maintained for the purge cycle. At the start of the purge cycle solenoid piloted spool valves are activated to isolate the transmitter from the process signal lines, followed by the energizing of a separate purge air solenoid valve that

allows high pressure purge air to flow to the measurement station or probe array, forcefully flushing out all particulate contaminants.

At the end of the timed purge cycle the purge air valve is de-energized to shut off the supply of compressed air. After a short period to allow the pressures in the signal lines to bleed down to process levels, the spool valves are shuttled to reconnect process signal lines to the attached transmitter and active process measurement resumes.

## Installation Guide

### Air Requirement

- 80 to 125 psig at 100 CFM, oil and dirt free.

### Line Size

- If the distance from the AUTO-purge Panel to the airflow measuring station or probe array is less than 25', tube size to be 1/2" O.D. with a wall thickness no greater than 0.065".
- If the distance from the AUTO-purge Panel to the airflow measuring station or probe array is 25' to 50', tube size to be 3/4" O.D. with a wall thickness no greater than 0.065".
- If the distance from the AUTO-purge Panel to the airflow measuring station or probe array is greater than 50', tube size to be 1.0" O.D. with a wall thickness no greater than 0.065".

### Ambient Temperature

- 40°F to 140°F. For ranges above or below this ambient temperature, the use of an enclosure heater and/or cooler is required.

### Accumulator Tank (strongly recommended)

- Requires coalescing filter, pressure regulator, and check valve at the tank inlet.
- 120 gallons – All CA stations.
- 120 gallons – Multiple VOLU-probes having a combined length greater than 10'.
- 80 gallons – One or more VOLU-probes having a combined length less than 10'.

### Line from Accumulator Tank to AUTO-purge Panel

- 25' maximum length, 1/2" pipe (minimum).
- Recommend locating accumulator tank as close as possible to AUTO-purge Panel.

### Electrical Power Requirement

- 74VA at 24VAC; 28W at 24VDC; 77VA at 120VAC.
- 120VAC, 5 amp when an optional enclosure heater is installed.

## Air Monitor's Product Families of Air & Coal Flow Measurement Systems



### **Pf-FLO™ – Pulverized Fuel Flow Management**

The Pf-FLO™ system performs continuous and accurate fuel flow measurement in pulverized coal fired combustion applications, providing boiler operators with the real-time data needed to balance coal mass distribution between burners. Balanced fuel improves combustion efficiency and lowers emissions while reducing in-furnace slagging, coal layout, fuel slagging, and coal pipe fires.

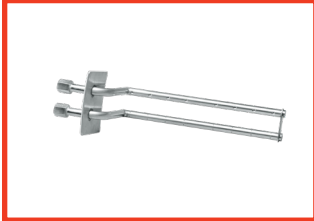

### **IBAM™ – Individual Burner Airflow Measurement**

The IBAM™ – Individual Burner Airflow Measurement probe is ideally suited for new or retrofit applications where a reduction in plant emissions and improvement in efficiency can be obtained through accurate measurement of burner secondary airflow. The IBAM™ probe has been designed to accurately measure in the particulate laden, high operating temperature conditions found in burner air passages.



### **VOLU-probe/SS™ Stainless Steel Airflow Traverse Probes**

Multi-point, self-averaging, Pitot-Fechheimer airflow traverse probes with integral airflow direction correcting design. Constructed of Type 316 stainless steel and available in externally and internally mounted versions for harsh, corrosive or high temperature applications such as fume hood, laboratory exhaust, pharmaceutical, and clean room production and dirty industrial process applications.



**CA™ – Combustion Airflow Measuring Station & VOLU-probe/SS™ Traverse Probes.** Air Monitor's duct mounted airflow measurement devices have been designed to accurately and repeatedly measure air mass flow in power plants. The Combustion Air (CA) Station™ includes honeycomb air straightener to accurately measure in shorter straight duct runs than any other flow measurement device. The VOLU-probe/SS™ delivers accurate airflow measurement performance in the form of an insertion probe. Both devices feature Type 316 stainless steel flow sensing arrays.



### **CEMS™ – Continuous Emissions Monitoring System**

Air Monitor's CEMS™ – Continuous Emissions Monitoring Systems assist in complying with the Clean Air Act's stringent emission measurement standards and the requirements of 40 CFR 75. Air Monitor has assembled a cost effective integrated system consisting of in-stack flow measurement equipment and companion instrumentation to provide continuous, accurate, and reliable volumetric airflow monitoring of stacks and ducts of any size and configuration.

**Engineering & Testing Services.** Air Monitor offers complete engineering and testing to analyze air and coal delivery systems. Air Monitor's field testing services use 3D airflow traversing and Pf-FLO coal flow measurement systems for the highest possible accuracy. To ensure cost effective and accurate solutions, Air Monitor has full scale physical flow modeling capability and in house Computational Fluid Dynamics (CFD). CFD analysis is used to analyze flow profiles and design/redesign ductwork to improve overall performance. Full scale model fabrication and certified wind tunnel testing is used to develop application specific products that will measure accurately where no standard flow measurement can.