

Data sheet

Differential pressure and flow controller (PN 25)

AVPQ - return mounting, adjustable setting

AVPQ 4 - flow mounting, adjustable setting

Description

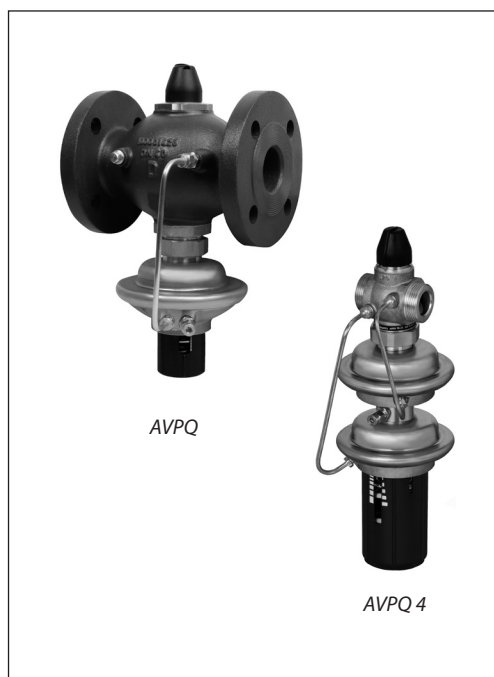

AVPQ(4) is a self-acting differential pressure and flow controller primarily for use in district heating systems. The controller closes on rising differential pressure or when set max. flow is exceeded.

The controller has a control valve with adjustable flow restrictor, an actuator with two control diaphragms and handle for differential pressure setting.

Main data:

- DN 15-50
- k_{vs} 0,4-25 m³/h
- Flow range: 0,015-15 m³/h
- PN 25
- Setting range: 0,2-1,0 bar/0,3-2,0 bar
- Flow restrictor Δp_s : 0,2 bar
- Temperature:
Circ. water / glycolic water up to 30% :
2 ... 150 °C
- Connections:
 - Ext. thread (weld-on, ext. thread and flange tailpieces)
 - Flange

Ordering

Example:
Differential pressure and flow controller; return mounting;
DN 15; k_{vs} 1,6; PN 25;
setting range 0,2-1,0 bar;
 T_{max} 150 °C; ext. thread

- 1x AVPQ DN 15 controller
Code No: **003H6531**
- 1x Impulse tube set AV, R 1/8
Code No: **003H6852**

Option:

- 1x Weld-on tailpieces
Code No: **003H6908**

The controller will be delivered completely assembled, inclusive impulse tube(s) between valve and actuator. External impulse tube (AV) must be ordered separately.

AVPQ Controller (return mounting)

Picture	DN (mm)	k_{vs} (m ³ /h)	Connection	Δp setting range (bar)	Code No.	Δp setting range (bar)	Code No.
	15	0,4	Cylindr. ext. thread acc. to ISO 228/1	G 3/4 A	003H6918	0,2-1,0	003H6920
		1,0			003H6919		003H6921
		1,6			003H6531		003H6539
		2,5			003H6532		003H6540
		4,0			003H6533		003H6541
		6,3			003H6534		003H6542
	20	8,0	Flanges PN 25, acc. to EN 1092-2	G 1 1/4 A	003H6535	0,3-2,0	003H6543
	25	12,5		G 1 3/4 A	003H6536		003H6544
	32	16		G 2 A	003H6537		003H6545
	40	20		G 2 1/2 A	003H6538		003H6546
	32	12,5			003H6563		003H6566
	40	20		003H6564	003H6567		
	50	25		003H6565	003H6568		

Ordering (continuous)

AVPQ 4 Controller (flow mounting)

Picture	DN (mm)	k _{vs} (m ³ /h)	Connection	Δp setting range (bar)	Code No.	Δp setting range (bar)	Code No.	
	15	0,4	Cylindr. ext. thread acc. to ISO 228/1	0,2-1,0	003H6922	0,3-2,0	003H6924	
		1,0			003H6923		003H6925	
		1,6			003H6547		003H6555	
		2,5			003H6548		003H6556	
		4,0			003H6549		003H6557	
	20	6,3			G 1 A		003H6550	003H6558
	25	8,0			G 1 1/4 A		003H6551	003H6559
	32	12,5			G 1 3/4 A		003H6552	003H6560
	40	16			G 2 A		003H6553	003H6561
	50	20			G 2 1/2 A		003H6554	003H6562
	32	12,5	Flanges PN 25, acc. to EN 1092-2	0,2-1,0	003H6569	0,3-2,0	003H6572	
	40	20			003H6570		003H6573	
	50	25			003H6571		003H6574	

Accessories

Picture	Type designation	DN	Connection	Code No.
	Weld-on tailpieces	15	-	003H6908
		20		003H6909
		25		003H6910
		32		003H6911
		40		003H6912
		50		003H6913
	External thread tailpieces	15	Conical ext. thread acc. to EN 10226-1	R 1/2 003H6902
		20		R 3/4 003H6903
		25		R 1 003H6904
		32		R 1 1/4 003H6905
		40		R 1 1/2 065B2004
		50		R 2 065B2005
	Flange tailpieces	15	Flanges PN 25, acc. to EN 1092-2	003H6915
		20		003H6916
		25		003H6917
	Impulse tube set AV	Description: - 1x copper tube Ø6 × 1 × 1500 mm - 1x compression fitting 1) for imp. tube connection to pipe Ø6 × 1 mm		R 1/8 003H6852
				R 3/8 003H6853
				R 1/2 003H6854
	¹⁾ 10 compression fittings for imp. tube connection to pipe, Ø6 × 1 mm R 1/8			003H6857
	¹⁾ 10 compression fittings for imp. tube connection to pipe, Ø6 × 1 mm R 3/8			003H6858
	¹⁾ 10 compression fittings for imp. tube connection to pipe, Ø6 × 1 mm R 1/2			003H6859
	¹⁾ 10 compression fittings for imp. tube connection to actuator, Ø6 × 1 mm G 1/8			003H6931
	Shut off valve Ø6 mm			003H0276

¹⁾ Compression fitting consists of a nipple, compression ring and nut.

Ordering (continuous)
Service kits

Picture	Type designation	DN	kvs (m ³ /h)	Code No.
	Valve insert	15	0,4	003H6861
			1,0	003H6862
			1,6	003H6863
			2,5	003H6864
			4,0	003H6865
		20	6,3	003H6866
		25	8,0	003H6867
		32 / 40 / 50	12,5 / 16 / 20 / 25	003H6868

Picture	Type designation	Δp setting range (bar)	Code No.	
			AVPQ	AVPQ 4
	Actuator with adjustable handle	0,2-1,0	003H6833	003H6838
		0,3-2,0	003H6850	003H6851

Technical data
Valve

Nominal diameter			DN	15		20	25	32	40	50			
k _{vs} value	Range of max. flow setting	Δp _b ¹⁾ = 0,2 bar	m ³ /h	0,4	1,0	1,6	2,5	4,0	6,3	8,0	12,5	16/20 ⁴⁾	20/25 ⁴⁾
				0,015	0,02	0,03	0,07	0,07	0,16	0,2	0,4	0,8	0,8
				0,18	0,4	0,86	1,4	2,2	3,0	3,5	8,0	10	12
				-	-	0,9	1,6	2,4	3,5	4,5	10	12	15
Cavitation factor z				≥ 0,6				≥ 0,55		≥ 0,5			
Leakage acc. to standard IEC 534			% of k _{vs}	≤ 0,02				≤ 0,05					
Nominal pressure			PN	25									
Min. differential pressure			bar	see remark ²⁾									
Max. differential pressure				20					16				
Medium			Circulation water / glycolic water up to 30%										
Medium pH			Min. 7, max. 10										
Medium temperature			°C	2 ... 150									
Connections		valve	External thread				Ext. thread and flange						
		tailpieces	Weld-on and external thread										
			Flange										
Materials													
Valve body		thread	Red bronze CuSn5ZnPb (Rg5)							Ductile iron EN-GJS-400-18-LT (GGG 40.3)			
		flange	-										
Valve seat		Stainless steel, mat. No. 1,4571											
Valve cone		Dezincing free brass CuZn36Pb2As											
Sealing		EPDM											
Pressure relieve system		Piston											

¹⁾ Δp_b - differential pressure over flow restrictor

²⁾ Depends on the flow rate and valve k_{vs}; For Q_{set} = Q_{max} → Δp_{min} ≥ 0,5 bar; For Q_{set} < Q_{max} → Δp_{min} = $\left(\frac{Q}{k_{vs}}\right)^2 + \Delta p_b$
³⁾ Higher max flow are achieved at higher differential pressures over AVPQ(4) controller. In general at Δp > 1-1,5 bar

⁴⁾ Flange valve body

Technical data (continuous)

Actuator

Type		AVPQ		AVPQ 4	
Actuator size	cm ₂	54			
Nominal pressure	PN	25			
Flow restrictor diff. pressure, Δpb	bar	0,2			
Diff. pressure setting ranges and spring colours	bar	0,2-1,0	0,3-2,0	0,2-1,0	0,3-2,0
		yellow	red	yellow	red
Materials					
Housing	Upper casing of actuator	Stainless steel, mat. No.1,4301			
	Lower casing of actuator	Dezincing free brass CuZn36Pb2As			
Diaphragm		EPDM			
Impulse tube		Copper tube Ø6 x 1 mm			

Application principles

- Return mounting

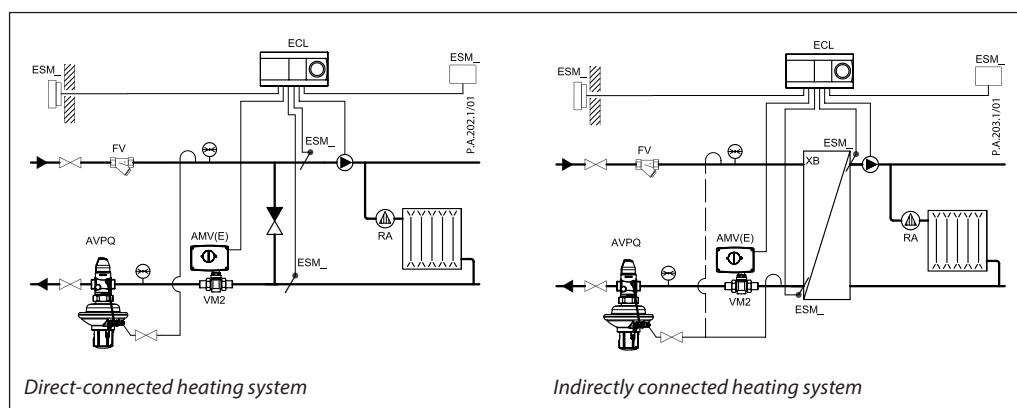

- Flow mounting

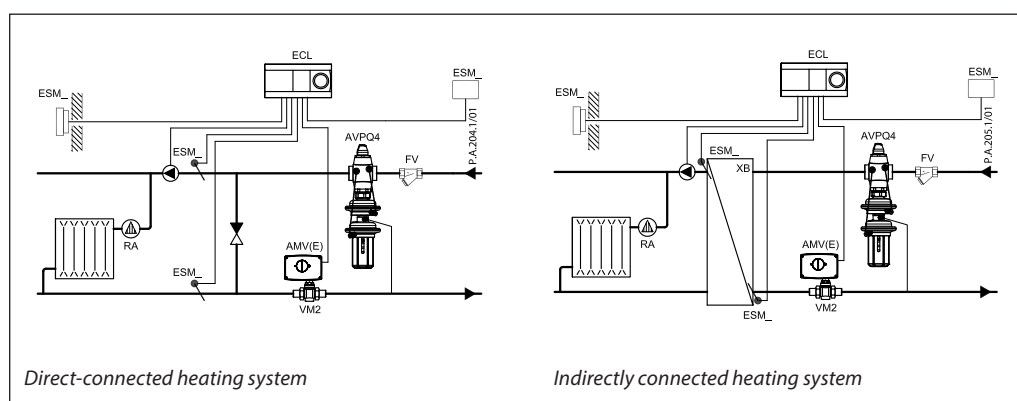

Installation positions

Up to medium temperature of 100 °C the controllers can be installed in any position.

For higher temperatures the controllers have to be installed in horizontal pipes only, with a pressure actuator oriented downwards.

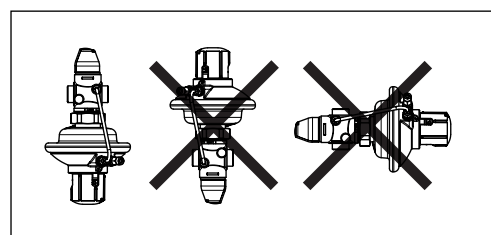
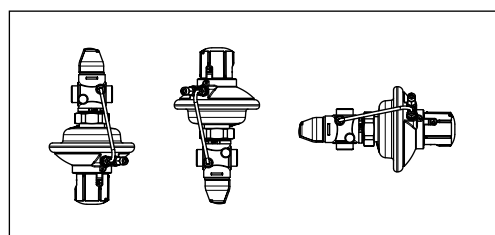

Pressure temperature diagram

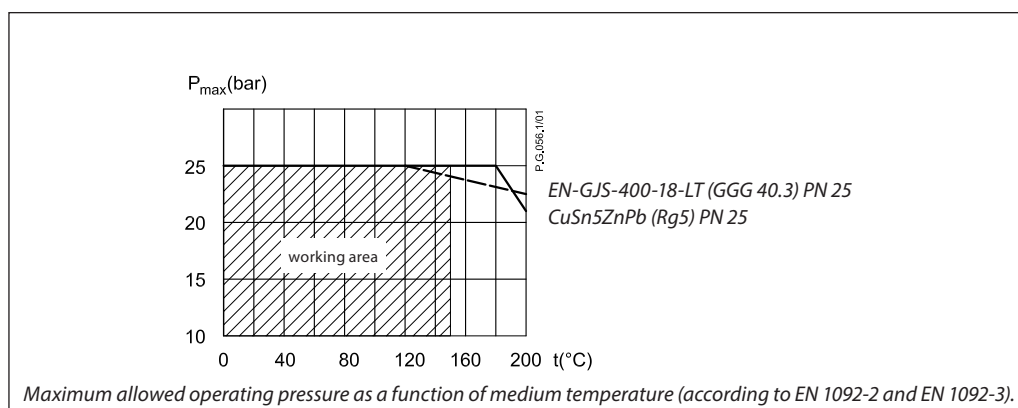

Flow diagram

Sizing and setting diagram

Relation between actual flow and number of revolutions on flow restrictor. Values given are approximate.

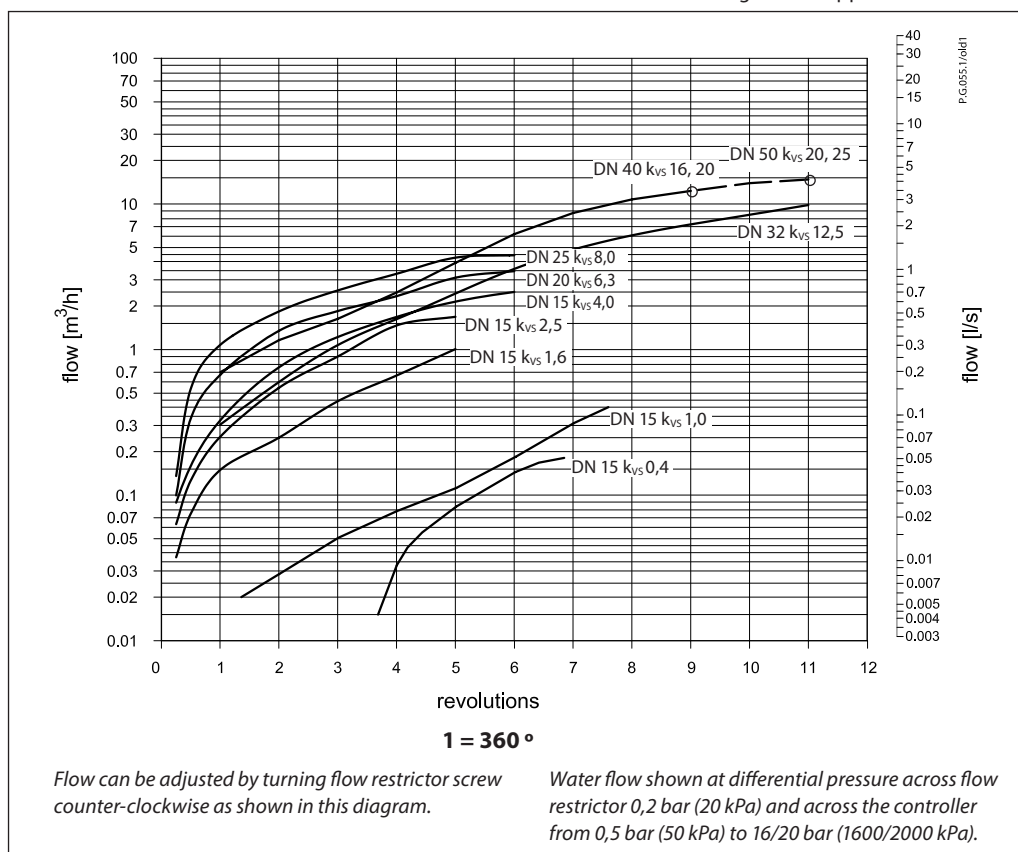

Remark:

Controllers DN 40 and DN 50 have the same curve up to 9 revolutions.

Note:

For max flow setting on the controller diagrams from Instructions should be used.

Sizing

- Directly connected heating system

Example 1

Motorised control valve (MCV) for mixing circuit in direct-connected heating system requires differential pressure of 0,3 bar (30 kPa) and flow less than 1900 l/h.

The total pressure loss across the controller is:

$$\Delta p_{AVPQ} = \Delta p_{min} - \Delta p_{MCV} = 0,9 - 0,3$$

$$\Delta p_{AVPQ} = 0,6 \text{ bar (60 kPa)}$$

Possible pipe pressure losses in tubes, shut-off fittings, heatmeters, etc. are not included.

Given data:

- $Q_{max} = 1,9 \text{ m}^3/\text{h}$ (1900 l/h)
- $\Delta p_{min} = 0,9 \text{ bar}$ (90 kPa)
- $\Delta p_{circuit}^{1)} = 0,1 \text{ bar}$ (10 kPa)
- $\Delta p_{MCV} = 0,3 \text{ bar}$ (30 kPa) selected
- $\Delta p_b^{2)} = 0,2 \text{ bar}$ (20 kPa)

k_v value is calculated according to formula:

$$k_v = \frac{Q_{max}}{\sqrt{\Delta p_{AVPQ} - \Delta p_b}} = \frac{1,9}{\sqrt{0,6 - 0,2}}$$

$$k_v = 3,0 \text{ m}^3/\text{h}$$

Remark:

¹⁾ $\Delta p_{circuit}$ corresponds to the required pump pressure in the heating circuit and is not to be considered when sizing the AVPQ(4).

²⁾ Δp_b is differential pressure over flow restrictor.

Solution:

The example selects AVPQ(4) DN 15, k_{vs} value 4,0, with differential pressure setting range 0,2-1,0 bar, flow setting range 0,07-2,4 m^3/h .

The differential pressure set value is:

$$\Delta p_{set \text{ value}} = \Delta p_{MCV}$$

$$\Delta p_{set \text{ value}} = 0,3 \text{ bar (30 kPa)}$$

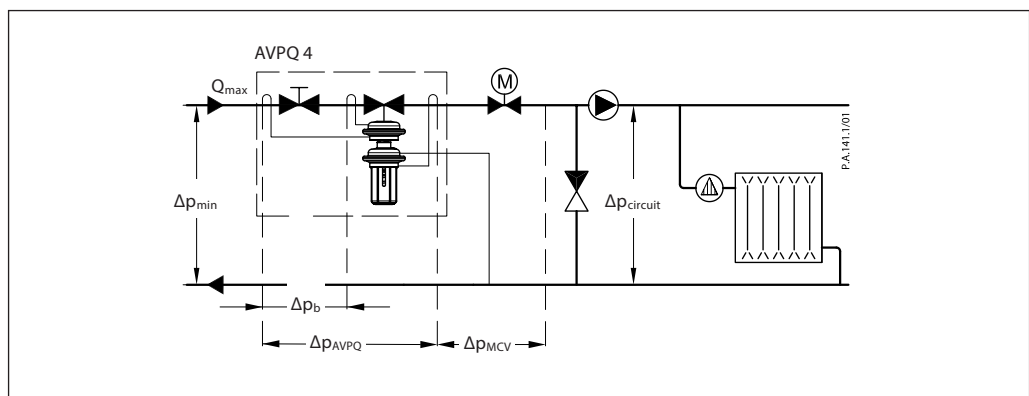
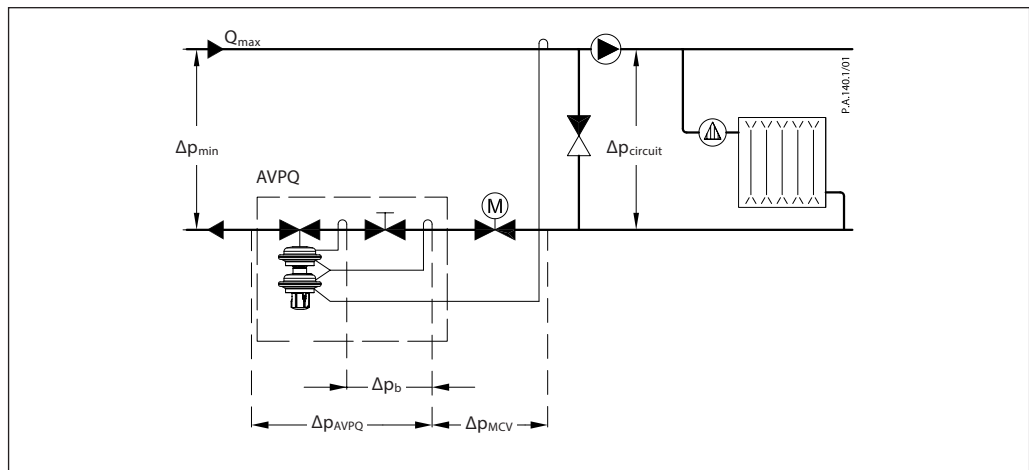

Sizing (continuous)

- Indirectly connected heating system

Example 2

Motorised control valve (MCV) for indirectly connected heating system requires differential pressure of 0,3 (30 kPa) bar and flow less than 1150 l/h.

Given data:

- $Q_{max} = 1,15 \text{ m}^3/\text{h}$ (1150 l/h)
- $\Delta p_{min} = 1,0 \text{ bar}$ (100 kPa)
- $\Delta p_{exchanger} = 0,05 \text{ bar}$ (5 kPa)
- $\Delta p_{MCV} = 0,3 \text{ bar}$ (30 kPa) selected
- $\Delta p_b^{1)} = 0,2 \text{ bar}$ (20 kPa)

Remark:

¹⁾ Δp_b is differential pressure over flow restrictor

The differential pressure set value is:

- $\Delta p_{set \text{ value}} = \Delta p_{exchanger} + \Delta p_{MCV}$
- $\Delta p_{set \text{ value}} = 0,05 + 0,3$
- $\Delta p_{set \text{ value}} = 0,35 \text{ bar}$ (35 kPa)

The total pressure loss across the controller is:

$$\Delta p_{AVPQ} = \Delta p_{min} - \Delta p_{exchanger} - \Delta p_{MCV}$$

$$\Delta p_{AVPQ} = 1,0 - 0,05 - 0,3$$

$$\Delta p_{AVPQ} = 0,65 \text{ bar} \text{ (65 kPa)}$$

Possible pipe pressure losses in tubes, shut-off fittings, heatmeters, etc. are not included.

k_v value is calculated according to formula:

$$k_v = \frac{Q_{max}}{\sqrt{\Delta p_{AVPQ} - \Delta p_b}} = \frac{1,15}{\sqrt{0,65 - 0,2}}$$

$$k_v = 1,7 \text{ m}^3/\text{h}$$

Solution:

The example selects AVPQ(4) DN 15, k_v s value 2,5, with differential pressure setting range 0,2-1,0 bar, flow setting range 0,07-1,6 m^3/h .

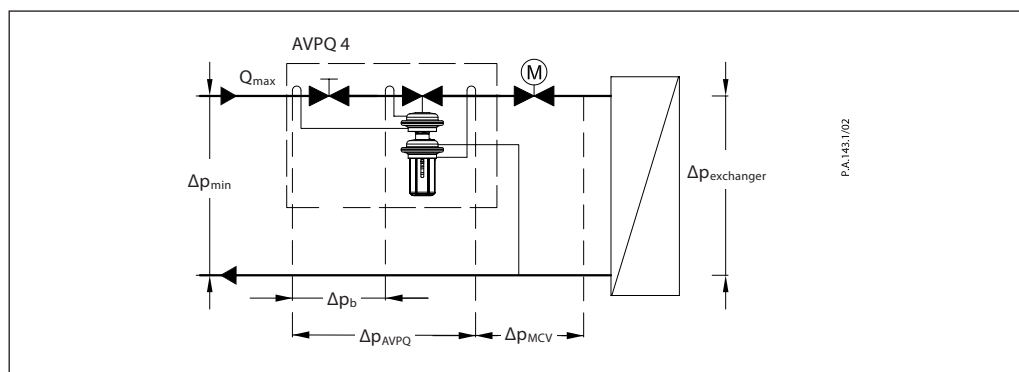
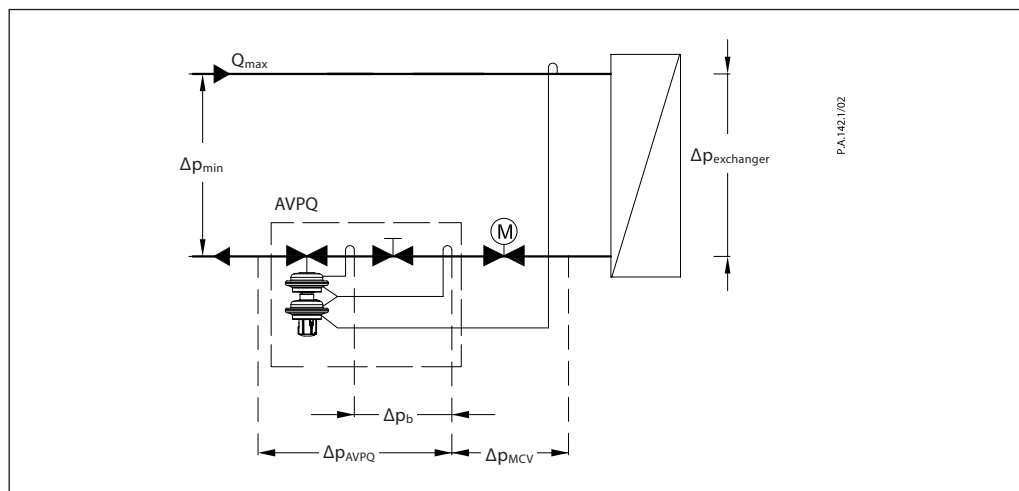

Design

- 1, Cover
- 2, Adjustable flow restrictor
- 3, Valve body
- 4, Valve insert
- 5, Pressure relieved valve cone
- 6, Valve stem
- 7, Control drain
- 8, Control diaphragm for flow control
- 9, Control diaphragm for diff. pressure control
- 10, Setting spring for diff. pressure control
- 11, Handle for diff. pressure setting, prepared for sealing
- 12, Adjuster for diff. pressure setting, prepared for sealing
- 13, Union nut
- 14, Compression fitting for impulse tube
- 15, Upper casing of actuator
- 16, Lower casing of actuator
- 17, Impulse tube
- 18, Excess pressure safety valve
- 19, Actuator

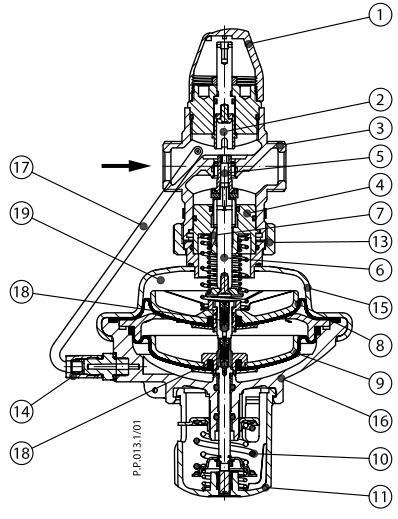

AVPQ (0,2-1,0 bar) - return mounting

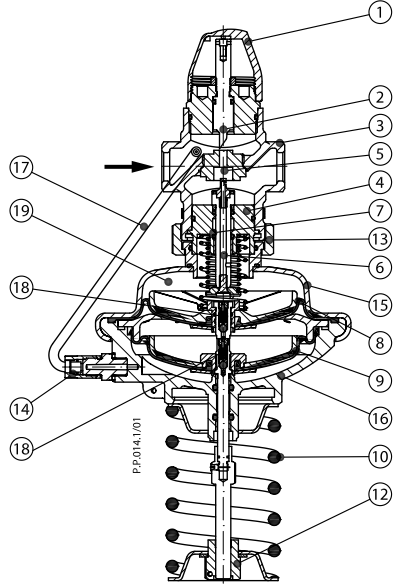

AVPQ (0,3-2,0 bar) - return mounting

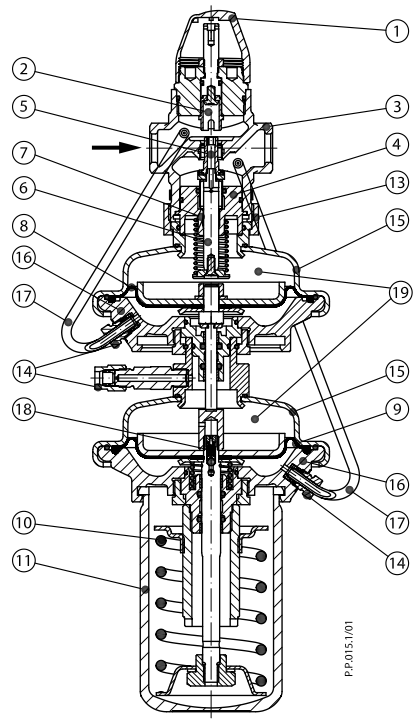

AVPQ 4 - flow mounting

Function

Flow volume causes pressure drop across the adjustable flow restrictor. Resulting pressures are being transferred through the impulse tubes and/or control drain in the actuator stem to the actuator chambers and act on control diaphragm for flow control. The flow restrictor diff. pressure is controlled and limited by means of built-in spring for flow control. Control valve closes on rising differential pressure and opens on falling differential pressure to control max flow.

Pressure changes from flow and return pipes are being transferred through the impulse tubes to the actuator chambers and act on control diaphragm for diff. pressure control. The diff. pressure is controlled by means of setting spring for diff. pressure control. Control valve closes on rising differential pressure and opens on falling differential pressure to maintain constant differential pressure.

Controller is equipped with excess pressure safety valve, which protects control diaphragm for diff. pressure control from too high differential pressure. In addition return version of controller is equipped with second excess pressure safety valve, which protects control diaphragm for flow control from too high differential pressure.

Settings

Flow setting

Flow setting is being done by the adjustment of the flow restrictor position. The adjustment can be performed on the basis of flow adjustment diagram (see relevant instructions) and/or by the means of heat meter.

Differential pressure setting

Differential pressure setting is being done by the adjustment of the setting spring for diff. pressure control. The adjustment can be done by means of handle for diff. pressure setting and/or pressure indicators.

Adjustment diagram

Relation between scale figures and differential pressure. Values given are approximate.

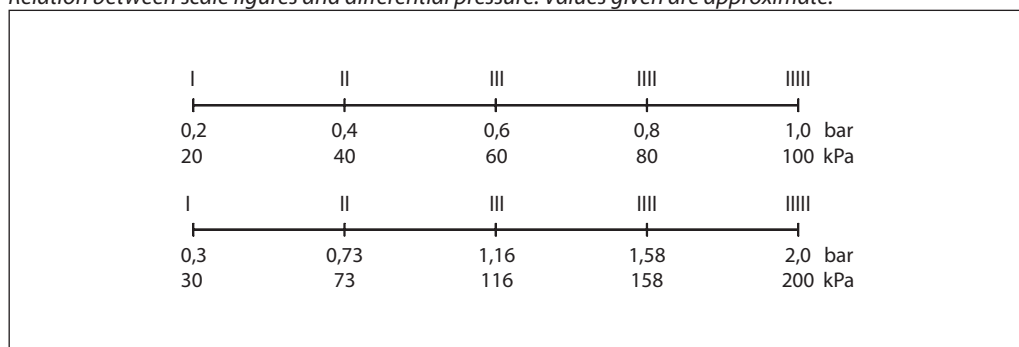

Dimensions

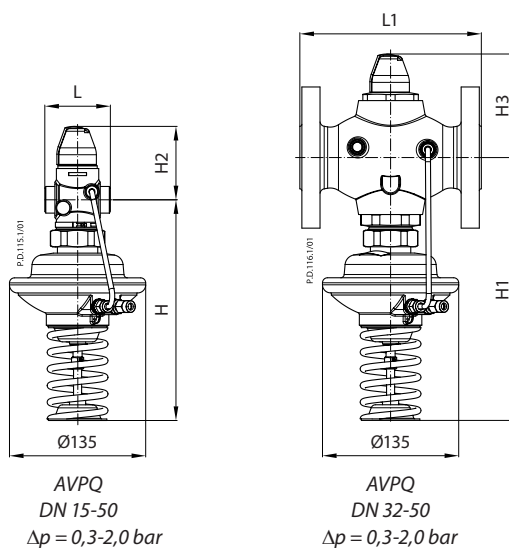

AVPQ ($\Delta p = 0,3-2,0$ bar)

DN		15	20	25	32	40	50
L	mm	65	70	75	100	110	130
L1		-	-	-	180	200	230
H		219	219	219	260	260	260
H1		-	-	-	260	260	260
H2		73	73	76	103	103	103
H3		-	-	-	103	103	103
Weight (thread)		kg	3,2	3,2	3,4	5,9	6,0
Weight (flange)	-		-	-	10,4	12,0	14,0

Note: Other flange dimensions - see table for tailpieces.

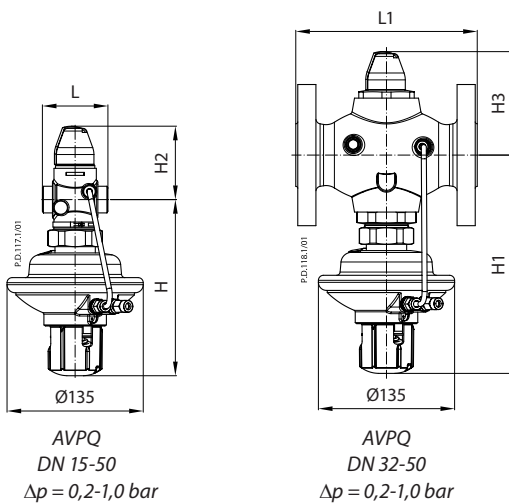

AVPQ ($\Delta p = 0,2-1,0$ bar)

DN		15	20	25	32	40	50
L	mm	65	70	75	100	110	130
L1		-	-	-	180	200	230
H		175	175	175	217	217	217
H1		-	-	-	217	217	217
H2		73	73	76	103	103	103
H3		-	-	-	103	103	103
Weight (thread)		kg	3,2	3,2	3,4	5,9	6,0
Weight (flange)	-		-	-	10,4	12,0	14,0

Note: Other flange dimensions - see table for tailpieces.

Dimensions (continuous)

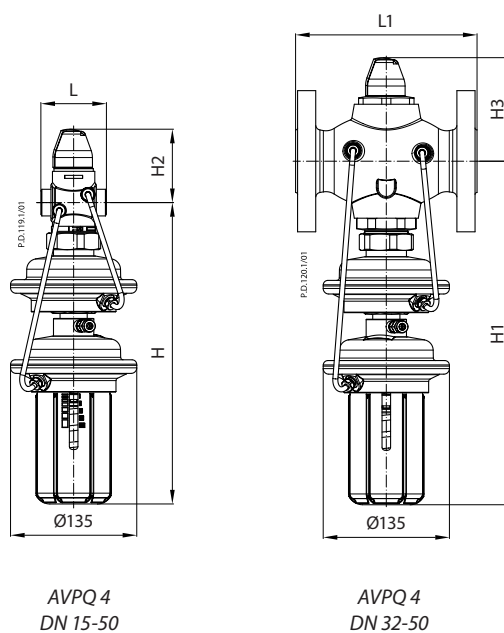

AVPQ 4

DN	15	20	25	32	40	50
L	65	70	75	100	110	130
L1	-	-	-	180	200	230
H	298	298	298	340	340	340
H1	-	-	-	340	340	340
H2	73	73	76	103	103	103
H3	-	-	-	103	103	103
Weight (thread)	5,4	5,4	5,6	8,1	8,2	8,9
Weight (flange)	-	-	-	12,5	14,1	16,2

Note: Other flange dimensions - see table for tailpieces.

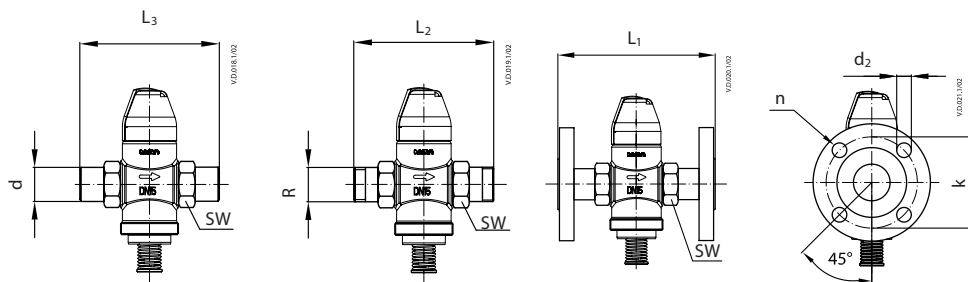

DN	R ¹⁾	SW	d	L ₁ ²⁾	L ₂	L ₃	k	d ₂	n
15	½	32 (G ¾A)	21	130	131	139	65	14	4
20	¾	41 (G 1A)	26	150	144	154	75	14	4
25	1	50 (G 1¼A)	33	160	160	159	85	14	4
32	1¼	63 (G 1¾A)	42	-	177	184	100	18	4
40	1½	70 (G 2A)	47	-	195	204	110	18	4
50	2	82 (G 2½A)	60	-	252	234	125	18	4

¹⁾ Conical ext. thread acc. to EN 10226-1

²⁾ Flanges PN 25, acc. to EN 1092-2

Compression fittings

