

SCC-S Sample gas feed unit

Operator's Manual

42/23-59 EN Rev. 1



Contents

Preface	3
Safety Information	4
Specified Use	4
Safety Instructions	5
Preparation for Installation	7
Requirements for the Installation Site, Power Supply	7
Sample Gas Inlet Conditions	8
Scope of Delivery	8
Dimensional Drawing	9
Sample Gas Feed Unit Installation	10
Unpacking the Sample Gas Feed Unit	10
Mounting the Sample Gas Feed Unit	11
Connecting the Gas Lines	13
Connecting the Electrical Leads	14
Sample Gas Feed Unit Start-Up	17
Power Supply and Sample Gas Activation	17
Sample Gas Pump Control	18
Peltier Cooler Control	19
Maintenance	20
Replacing the Condensate Pump Hose	20
Replacing the Condensate Pump Pressure Rollers and Springs	22
Replacing the Diaphragm and Valve Plates in the Diaphragm Pump	24
Checking Gas Path Seal Integrity	27
Troubleshooting	28
Shutting Down and Packing	29
Shutting Down the Sample Gas Feed Unit	29
Packing the Sample Gas Feed Unit	30
Annex	31
Pneumatic Diagrams	31
Circuit Diagrams	35
Index	38

Preface

Content of the Operator's Manual

This operator's manual contains all the information you need to install, commission, operate and maintain the SCC-S sample gas feed unit safely and in accordance with the regulations.

This operator's manual contains information on all the functional units in the SCC-S sample gas feed unit. The delivered sample gas feed unit may differ from the version described.

Further Information

Internet

You will find information about the products and services of ABB Analytical on the Internet at "<http://www.abb.com/analytical>".

Spare Parts

You can order spare parts via our service "Parts OnLine". You will find Parts OnLine on the Internet at "<http://www.abb.com/partsonline>".

Service Contact

If the information in this Operator's Manual does not cover a particular situation, ABB after sales service will be pleased to provide further information.

Please contact your local service representative. For emergencies, please contact

ABB Service,
Telephone: +49-(0)180-5-222580, Telefax: +49-(0)621-38193129031,
E-mail: automation.service@de.abb.com

Symbols and Typefaces in the Operator's Manual

WARNING denotes safety instructions which must be followed when handling the device, in order to prevent danger to user.

NOTE denotes information about particular features with regard to the handling of the device and the use of this operator's manual.

1, 2, 3, ... denotes the reference numbers in the figures.

CHAPTER 1

Safety Information

Specified Use

Specified Use

The SCC-S sample gas feed unit is designed for continuous dosed sample gas feeding.

The SCC-S sample gas feed unit with Peltier cooler is additionally designed for cooling the sample gas and separating and removing the condensate.

Any other application is not compliant with the specified use.

Observation of this operator's manual is also part of the specified use.

The SCC-S sample gas feed unit must not be used

- For feeding mixtures of gas/air or gas/oxygen that are capable of ignition during normal service,
- For feeding flammable gas which may form an explosive mixture with air or oxygen, and
- In a potentially explosive atmosphere or in hazardous areas.

Safety Instructions

Requirements for Safe Operation

In order to operate in a safe and efficient manner the device should be properly handled and stored, correctly installed and set-up, properly operated and correctly maintained.

Personnel Qualifications

Only persons familiar with the installation, set-up, operation and maintenance of comparable devices and certified as being capable of such work should work on the device.

Special Information and Precautions

These include

- The content of this operator's manual,
- The safety information affixed to the device,
- The applicable safety precautions for installing and operating electrical devices,
- Safety precautions for working with gases, acids, condensates, etc.

National Regulations

The regulations, standards and guidelines cited in this operator's manual are applicable in the Federal Republic of Germany. The applicable national regulations should be followed when the device is used in other countries.

Device Safety and Safe Operation

The device is designed and tested in accordance with the relevant safety standards and has been shipped ready for safe operation. To maintain this condition and to assure safe operation, read and follow the safety information in this operator's manual. Failure to do so can put persons at risk and can lead to device damage as well as damage to other systems and devices.

Protective Lead Connection

The protective lead (ground) should be attached to the protective lead connector before any other connection is made.

Risks of a Disconnected Protective Lead

The device can be hazardous if the protective lead is interrupted inside or outside the device or if the protective lead is disconnected.

Risks Involved in Opening the Covers

Current-bearing components can be exposed when the covers or parts are removed, even if this can be done without tools. Current can be present at some connection points.

Risks Involved in Working with an Open Device

All work on a device that is open and connected to power should only be performed by trained personnel who are familiar with the risks involved.

When Safe Operation can no Longer be Assured

If it is apparent that safe operation is no longer possible, the device should be taken out of operation and secured against unauthorized use.

The possibility of safe operation is excluded:

- If the device is visibly damaged,
- If the device no longer operates,
- After prolonged storage under adverse conditions,
- After severe transport stresses.

CHAPTER 2

Preparation for Installation

Requirements for the Installation Site, Power Supply

Short Gas Paths

The sample gas feed unit should be installed as close as possible to the gas analyzer.

Adequate Air Circulation

Ensure adequate natural air circulation around the sample gas feed unit. Avoid heat buildup.

Protection against Adverse Environmental Conditions

The sample gas feed unit should be protected from

- Cold,
- Heat sources such as the sun, furnaces, boilers,
- Large temperature variations,
- Strong blasts,
- Accumulations of dust and dust infiltration,
- Corrosive atmospheres,
- Vibration.

Environmental Conditions

Ambient temperature	+10 to +40 °C during operation -25 to +60 °C during storage and transport
Relative air humidity	≤ 75 % year-round average, ≤ 95 % on 30 days per year, occasional light condensation permissible

Power Supply

Input voltage	230 VAC, ± 10 %, 50 Hz or 115 VAC, ± 10 %, 60 Hz
Power consumption	230 VAC, 50 Hz: max. 300 VA

Sample Gas Inlet Conditions

Sample Gas Inlet Conditions

Sample gas pressure	$p_{\text{abs}} = 70 \text{ to } 105 \text{ kPa (0.7 to 1.05 bar)}$
Sample gas flow rate	Gas path: 7 to 70 l/h Bypass: 15 to 150 l/h (not in versions with Peltier cooler)
Sample gas inlet temperature	+10 to +50 °C
Sample gas inlet dew point	Version without Peltier cooler: The sample gas dew point should be at least 5 °C below the lowest ambient temperature throughout the sample gas path. If this is not the case, then a sample gas cooler unit or a condensate trap is required. Version with Peltier Cooler: max. 50 °C (at max. +25 °C ambient temperature)

Scope of Delivery

Scope of Delivery

Quantity	Description
1	SCC-S Sample gas feed unit
1	Power supply cable, length 2 m
1	Socket plug, 8-pole, for signal line connection
2	Operator's manuals (1 copy in German, 1 in English)

Dimensional Drawing

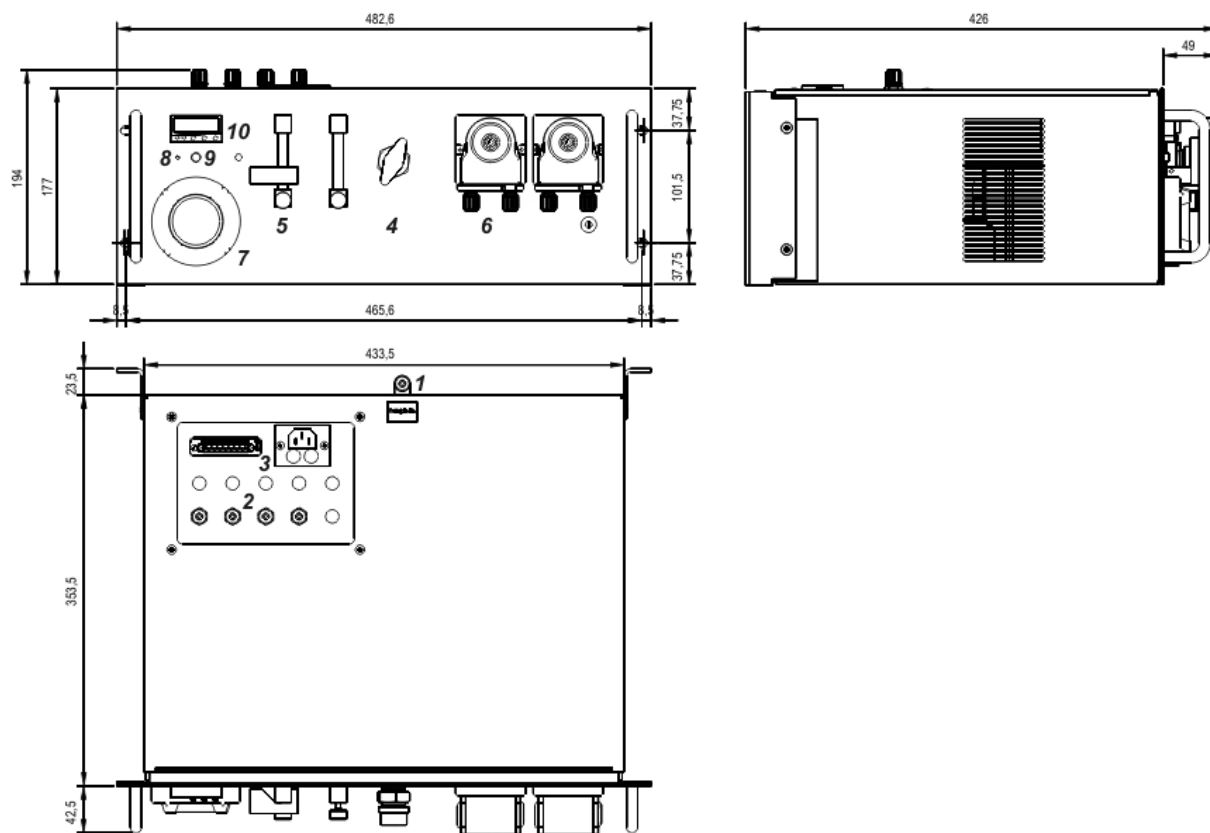

Dimensional drawing (dimensions in mm)

- 1** Sample gas inlet
- 2** Sample gas outlet, bypass outlet and test gas inlets via ball valve or solenoid valve
- 3** Power supply connection and electrical connection for status signal, solenoid valve control and 24 VDC
- 4** Ball valve for infeed of test gas
- 5** Flow monitor with needle valve (Option: second flow monitor for bypass)
- 6** Peristaltic pump (Option: second peristaltic pump for external cooler)
- 7** Membrane filter or condensate monitor
- 8** LED indicator for condensate alarm, red
- 9** Pump switch
- 10** Temperature controller for cooler

NOTE

When mounting, allow for the additional space required for the cooling air outlet on the left and right side of the unit (min. 3.5 cm).

Remark: The illustration shows options. The scope and features of the ordered version may differ.

CHAPTER 3

Sample Gas Feed Unit Installation

Unpacking the Sample Gas Feed Unit

In the event of transport damage attributable to improper handling, instigate damage assessment by the carrier (rail, post office, forwarder) within seven days.

Make sure that none of the enclosed accessories are lost during unpacking.

Keep the transport box and padding material for any future transportation which might be necessary.

Mounting the Sample Gas Feed Unit

NOTES

Max. inclination of the instrument 5°. A distance of at least 1 height unit from devices which develop heat is required for the version with Peltier cooler. When mounting, allow for the additional space required for the cooling air outlet on the left and right side of the unit (min. 3.5 cm).

Sample Gas Feed Unit Installation on the Wall

Mount the sample gas feed unit to the wall using 4 M6 screws (not supplied). The fixing brackets required for this purpose are screwed securely on the rear of the side panels in the factory.

To enable the cooling air to pass unobstructed into the unit to the rear, the projection of the fixing brackets of approx. 2.5 cm to the rear wall, which is set up in the factory, must not be reduced.

Sample Gas Feed Unit Installation in a 19-Inch Cabinet/Rack

If necessary, remove the adhesive pads from the bottom.

If necessary, install mounting rails in the cabinet/rack.

Mount the sample gas feed unit in a 19-inch cabinet/rack using 4 M6 screws (not supplied).

Desktop Installation

If necessary, unscrew the mounting brackets from the rear of the side panels.

If necessary, exchange the fittings flange with the blank flange.

Exchanging the Fittings Flange with the Blank Flange

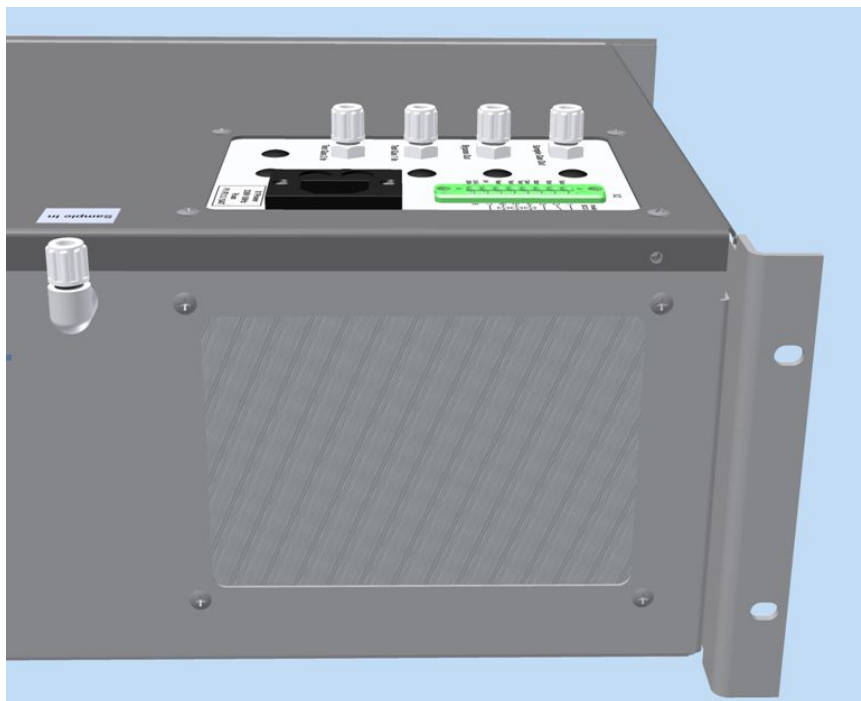

View from behind

- 1 Loosen the 2 fixing screws and open the housing cover.
- 2 Loosen the 4 fixing screws each on the fittings flange and on the blank flange.
- 3 Exchange the fittings flange with the blank flange. Take care not to bend or squash any hoses.
- 4 Close the housing cover and secure it with the 2 fixing screws.

The sample gas inlet port can be swiveled by $\pm 90^\circ$.

Connecting the Gas Lines

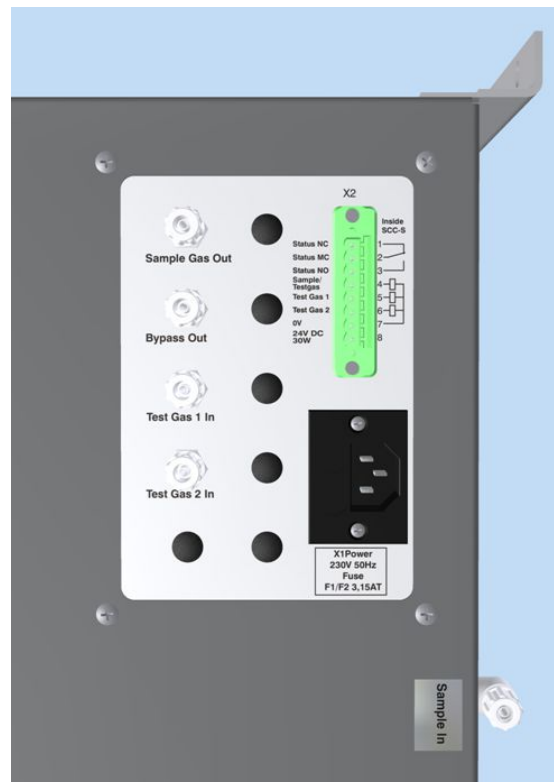

Gas connections (view from above)

Gas Connections

The gas connections are PVDF or PPH fittings for DN 4/6 mm hose.

Gas Line Connection

Connect the gas lines to the gas inlet and outlet fittings. The gas lines should be made from material that is suited to the measuring task.

Connecting the Electrical Leads

WARNING

Please observe the relevant national safety regulations for the construction and operation of electrical installations as well as the following safety instructions.

Before connecting the power supply, check that the operating voltage on the rating plate is the same as the mains voltage.

The protective-conductor terminal must be connected to a protective conductor before any other connections are set up.

The device can be dangerous if the protective conductor is interrupted inside or outside the device or the protective-conductor terminal is disconnected.

Use only fuses of the specified type and rated current as replacements. Never use patched fuses. The fuse holder must not be short-circuited.

NOTE:

The signal lines should be routed separately from the power supply lines.

Connecting the Signal Lines

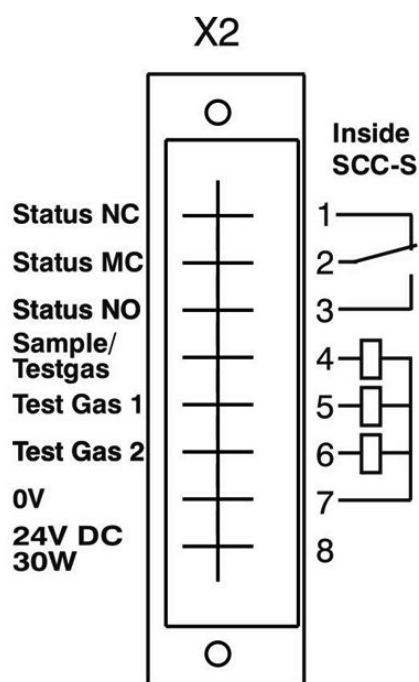

Signal line connections

- 1–3** Status signal of the cooler, flow and condensate monitoring: potential-free changeover contact, contact load 24 V DC/AC, 1 A
- 4** Activation of solenoid valve Sample/Test gas
- 5** Activation of solenoid valve Test gas 1
- 6** Activation of solenoid valve Test gas 2
- 7** Internal power supply 0 V
- 8** Internal power supply +24 V DC

"Inside SCC-S" means: The connection diagram shows the internal wiring of the sample gas feed unit.

The integrated power supply can also be used for the supply of external solenoid valves:

Terminal 7 = 0 V, terminal 8 = +24 V, maximum capacity 30 VA at 24 V DC.

Connect the signal lines (recommendation: 1.5 mm²) to the 8-pole socket plug (in scope of delivery).

Connecting the Power Supply

- 1** Make sure the voltage setting shown on the rating plate matches the line voltage.
The operating voltage cannot be switched over.
- 2** Make sure the power supply leads have an adequately dimensioned protective device (breaker).
- 3** Install a switched outlet or a breaker in the power supply wiring near the sample gas feed unit. This should allow the sample gas feed unit to be completely disconnected from the power supply if necessary.
The disconnection device should be easily accessible and identified in such a way that its relationship to the equipment that it is designed to disconnect can be clearly seen.
- 4** Connect the delivered power supply cable to the power supply.
The sample gas feed unit may start when the power supply is connected.

CHAPTER 4

Sample Gas Feed Unit Start-Up

Power Supply and Sample Gas Activation

WARNING

Before activating the power supply check once again that the operating voltage setting (see rating plate) matches the line voltage.
The needle valve must never be closed completely.
The sample gas must not be switched on until the cooler's lead time has finished.

Power Supply and Sample Gas Activation

Version without Peltier Cooler

- 1 Activate the power supply.
- 2 The sample gas feed unit is ready for operation without delay.
- 3 The sample gas must not be switched on until the upstream cooler unit's lead time has finished.
- 4 Set the sample gas flow using the needle valve (max. 70 l/h).

Version with Peltier Cooler

- 1 Activate the power supply.
- 2 The condensate pump starts to run.
- 3 The lead time is approx. 10 minutes.
The flow alarm and the cooler temperature alarm are present during the lead time. The condensate alarm may also be present.
- 4 The lead time is finished and the sample gas feed unit is ready for operation when the sample gas outlet temperature of the Peltier cooler is within the factory-set limit values ("K1" LED on the temperature controller lights up yellow). The sample gas pump starts to run if the "Pump" push-button is pressed (lights up green).
The sample gas pump can be switched off with the "Pump" push-button.
- 5 The sample gas may be switched on.
- 6 Set the sample gas flow using the needle valve (max. 70 l/h).

Sample Gas Pump Control

Operation

The "Pump" push-button must always be pressed during operation (lights up green).

The sample gas pump can be switched off with the "Pump" push-button, e.g. for maintenance work.

Alarm

(only in the version with Peltier cooler)

The sample gas pump is switched off when

- a condensate alarm ("Alarm" LED next to the "Pump" push-button lights up red) or
- a cooler temperature alarm ("K1" LED on the temperature controller is off)

is present. The "Pump" push-button continues to light up green.

After Power Failure

The jumper JP1 located on the circuit board can be used to set whether the sample gas pump restarts automatically after a power failure:

Jumper in position 1–2: The sample gas pump does not restart (factory-set).

Jumper in position 2–3: The sample gas pump restarts automatically.

Peltier Cooler Control

Cooler Control

State	Indication	Controller LED K1	Controller LED K2
After start-up	> 5 °C (room temp.)	Off (pump off & status alarm)	Lights up constantly yellow (cooling)
After lead time end (approx. 10 min)	≤ 5.5 °C	Lights up yellow (pump is switched on ¹ , status alarm switches to "good" state)	Lights up constantly yellow (cooling)
Normal operation	3 °C	Lights up yellow	Blinks (cooler regulation)
Cooler overloaded	> 3,5 °C	Lights up yellow	Lights up constantly yellow (cooling)
	> 5 °C	Off (pump off & status alarm)	Lights up constantly yellow (cooling)
Ambient temperature too low	< 2,5 °C	Lights up yellow	Off
	< 0 °C	Off (pump off & status alarm)	Off

1 if no condensate alarm is present and sample gas pump is switched on ("Pump" push-button lights up green)

See section "Troubleshooting", page 28, for further information on cooler problems.

Changing the Sample Gas Outlet Temperature

The set point for the sample gas outlet temperature (factory-set to +3 °C) can be changed at the temperature controller:

- 1 Press key P; the set point is displayed.
- 2 Use arrow keys to adjust the set point.
- 3 Press key P; the new set point is stored.

CHAPTER 5

Maintenance

WARNING

The operations described in this chapter require specialized knowledge, and sometimes involve the necessity of working on the sample gas feed unit with its cover open and live. They must therefore only be carried out by qualified and specially trained persons.

Replacing the Condensate Pump Hose

When does the hose need to be replaced?

Depending on the operating cycle, the condensate pump hose should be replaced at least every 5 months.

NOTE

Use only an original pump hose as replacement part to ensure trouble-free operation. Never lubricate the condensate pump hose.

WARNING

Residues from the condensate that the pump has been feeding may be found in the pump hose and the connected hoses. These media can flow out when the hose connections are opened. Take appropriate measures where needed to collect such residues. The medium being fed may be corrosive and poisonous! Appropriate precautions must be taken! Wear protective goggles and protective clothing!

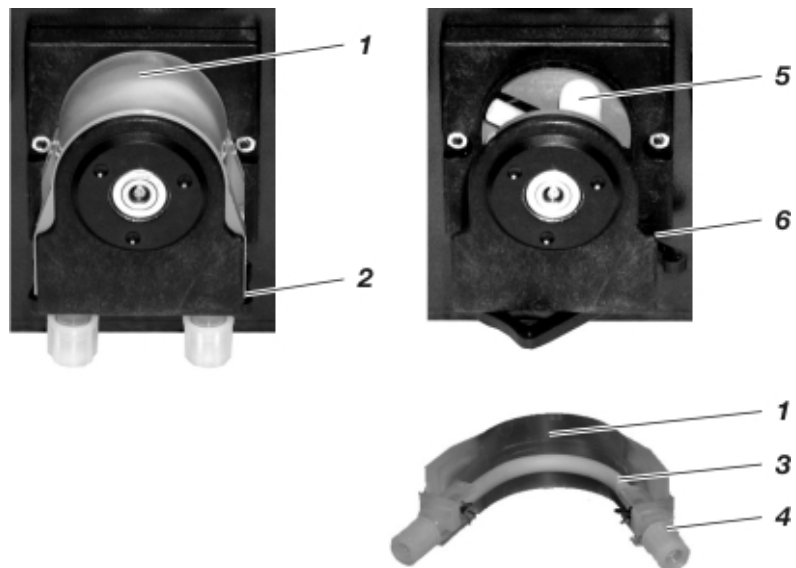

Condensate pump, hose and pump head with roller mounting

- | | | | | | |
|----------|-------------|----------|------------------|----------|------------------|
| 1 | Moving belt | 3 | Hose | 5 | Pressure rollers |
| 2 | S-clip | 4 | Hose connections | 6 | Dovetail guides |

Replace Condensate Pump Hose

Shut down the sample gas feed unit:

- 1 Stop the sample gas supply and shut off the sample gas feed unit power supply.

Remove the old hose:

- 2 Disconnect the external hoses from the hose connections.
- 3 Using the handles, press the moving belt **1** together and turn the S-clip **2** as far as its limit stop. Remove the moving belt with hose from the pump head.
- 4 Pull the old hose **3** by the hose connections **4** to release it from the moving belt's guides.
- 5 Press the pressure rollers **5** together and check the spring pressure; if it is too weak, then the pressure springs and possibly rollers should be replaced (see section "Replacing the Condensate Pump Pressure Rollers and Springs", page 22)

Fit a new hose:

- 6 Before reassembling the hose pump, check all the parts for dirt and, if necessary, clean them with a dry cloth or oil-free compressed air. Do not use solvents for cleaning as they can attack the plastic parts.
- 7 Insert a new hose **3** with hose connections in the guides on the moving belt **1**.
- 8 Insert moving belt **1** with the new hose in the dovetail guides **6** in the pump head. Using the handles, press the moving belt together while at the same time turning the S-clip **2** until it engages.
- 9 Connect the external hoses to the hose connections.

Restart the sample gas feed unit:

- 10 Switch on power supply to the sample gas feed unit.
- 11 The sample gas flow should only be restarted after the lead time period.

Replacing the Condensate Pump Pressure Rollers and Springs

When do the Pressure Rollers and Springs need to be Replaced?

The pressure rollers in the condensate pump must be replaced when their surface is damaged.

The pressure springs in the condensate pump must be replaced when they are broken.

NOTE

All four pressure springs must be replaced at the same time to ensure trouble-free operation.

WARNING

Residues from the condensate that the pump has been feeding may be found in the pump hose and the connected hoses. These media can flow out when the hose connections are opened. Take appropriate measures where needed to collect such residues. The medium being fed may be corrosive and poisonous! Appropriate precautions must be taken! Wear protective goggles and protective clothing!

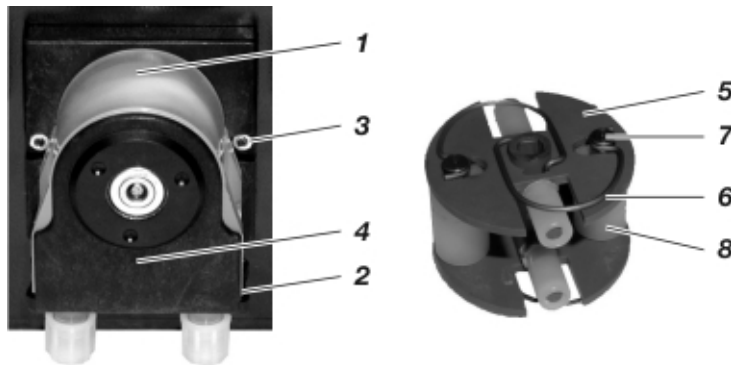

Condensate Pump, Roller Mounting

- | | | | |
|----------|---|----------|------------------------|
| 1 | Moving belt | 5 | Roller mounting |
| 2 | S-clip | 6 | Pressure springs (x 4) |
| 3 | Screws for securing the pump head (x 2) | 7 | Roller axle |
| 4 | Pump head | 8 | Pressure roller (x 2) |

Replace Pressure Rollers and Springs

Shut down the sample gas feed unit:

- 1 Stop the sample gas supply and shut off the sample gas feed unit power supply.

Remove the hose:

- 2 Disconnect the external hoses from the hose connections.
- 3 Using the handles, press the moving belt **1** together and turn the S-clip **2** as far as its limit stop. Remove the moving belt with hose from the pump head.

Dismantle the pump head:

- 4 Unscrew the two screws **3** that secure the pump head.
- 5 Pull the pump head **4** off the roller mounting axle, and remove the roller mounting **5** from the pump head.

Replace pressure rollers and springs:

- 6 Press the pressure springs **6** slightly together and pull them out of the hole in the roller mounting **5** and out of the retaining slot in the roller axle **7**. Remove the roller axle from the roller mounting, and pull the pressure roller **8** off the roller axle.
- 7 Before reassembling the hose pump, check all the parts for dirt and, if necessary, clean them with a dry cloth or oil-free compressed air. Do not use solvents for cleaning as they can attack the plastic parts.
- 8 Push the new pressure roller **8** onto the roller axle **7** and secure with new pressure springs **6** in the roller mounting **5**.

Fit the pump head:

- 9 Insert the roller mounting **5** in the pump head **4**, and push both components together onto the roller mounting axle. During this process, check to ensure that the roller mounting axle and roller mounting fit together properly and that the flange on the rotating axis points towards the pump head front.
- 10 Secure the pump head **4** with the two screws **3**.

Refit the hose:

- 11 Insert moving belt **1** with the hose in the dovetail guides in the pump head. Using the handles, press the moving belt together while at the same time turning the S-clip **2** until it engages.
- 12 Connect the external hoses to the hose connections.

Restart the sample gas feed unit:

- 13 Switch on power supply to the sample gas feed unit.
- 14 The sample gas flow should only be restarted after the lead time period.

Replacing the Diaphragm and Valve Plates in the Diaphragm Pump

When do the Diaphragm and Valve Plates need to be Replaced?

The diaphragm and valve plates in the diaphragm pump must be replaced when the diaphragm pump no longer feeds gas efficiently enough.

WARNING

Residues from the gas that the pump has been feeding may be found on the diaphragm and valve plates. These materials can flow out when the diaphragm pump is opened. Take appropriate measures where needed to collect such residues. The medium being fed may be corrosive and poisonous! Appropriate precautions must be taken! Wear protective goggles and protective clothing!

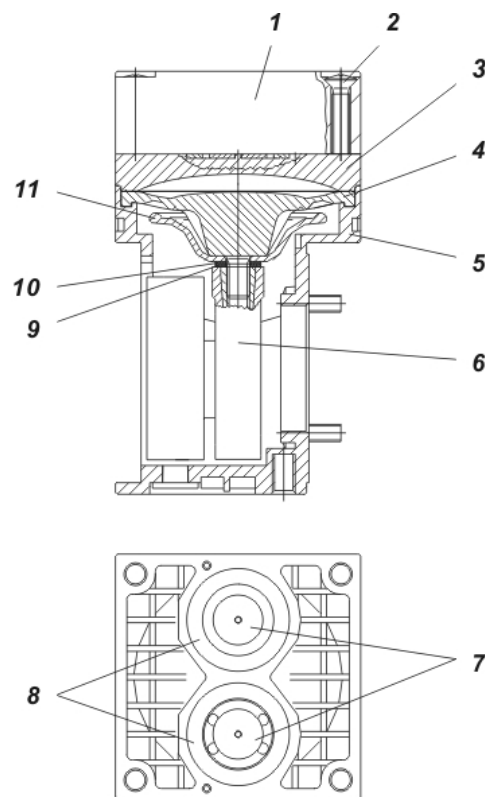

Diaphragm Pump

- | | | | |
|----------|----------------------|-----------|-------------------|
| 1 | Head cap | 7 | Valve plates |
| 2 | Head cap screws | 8 | Sealing rings |
| 3 | Spacer plate | 9 | Belleville spring |
| 4 | Structural diaphragm | 10 | Distance ring(s) |
| 5 | Casing | 11 | Supporting bell |
| 6 | Connecting rod | | |

Replace the Diaphragm and Valve Plates in the Diaphragm Pump

Shut down the sample gas feed unit:

- 1 Stop the sample gas supply and shut off the sample gas feed unit power supply.

Dismount the diaphragm pump:

- 2 Remove the case cover of the sample gas feed unit.
- 3 Disconnect the pump's power supply leads, remove the hoses from pump's connections and dismount the pump from the case of the sample gas feed unit.
- 4 Mark both pump hoses: The pump inlet hose is connected to the diaphragm filter outlet and the pump outlet hose is connected to the flow meter inlet.
- 5 Clean the outside of the pump.

Remove the pump head:

- 6 Mark the head cap **1**, spacer plate **3** and casing **5** with a felt pen. This prevents the possibility of these parts being fitted incorrectly when the pump is reassembled later.
- 7 Undo the four head cover screws **2** and remove the head cap along with the spacer plate from the pump casing.

Replace diaphragm:

- 8 Move the structural diaphragm **4** by rotating the fan impeller to its upper return point.
- 9 Hold opposite sides of the structural diaphragm, raise it, then remove it by rotating in an anticlockwise direction. Ensure that the cup spring **9** and the adjusting washer(s) **10** do not fall into the case from the threaded bolt of the structure diaphragm.
- 10 Remove the cup spring **9**, adjusting washer(s) **10** and support bowl **11** from the threaded bolt of the structure diaphragm and keep them.
- 11 Check all the parts for dirt and, if necessary, clean them with a dry cloth or compressed air. Do not use solvents for cleaning as they can attack the plastic parts.
- 12 Push the supporting bell, the distance ring(s) and the Belleville spring in that order onto the threaded bolt of the new structural diaphragm. The disk edge of the spring must be aligned with the structural diaphragm.
- 13 Move the connecting rod **6** to its upper return point.
- 14 Screw the new structural diaphragm with support bell, distance ring(s) and Belleville spring onto the connecting rod and hand-tighten it.

Replace the valve plates:

- 15** Separate head cap **1** from the spacer plate **3**.
- 16** Remove the valve plates **7** and the sealing rings **8** from the spacer plate.
- 17** Check that the valve seats, spacer plate and head cap are clean; if any of them display unevenness, scratches or corrosion they should be replaced.
- 18** Insert the new valve plates in the valve seats on the spacer plate. The valve plates for the compression and suction sides are identical; the same applies to the upper and lower sides of the valve plates.
- 19** Move the valve plates gently in a horizontal plane to ensure that they are not locked.
- 20** Insert sealing rings in the spacer plate.

Fit the pump head:

- 21** Move the structural diaphragm **4** by rotating the fan impeller to its upper return point.
- 22** Place the intermediate plate **3** with valve plates **7** and sealing gaskets **8** and head cover **1** on the case according to the markings.
- 23** Check that the head cap is centered correctly by moving it gently sideways.
- 24** Tighten the head cap screws **2** crosswise only slightly.
- 25** Check that the pump moves freely by rotating the fan impeller.
- 26** Move the structural diaphragm **4** by rotating the fan impeller to its upper return point.
- 27** Hand-tighten the head cap screws.

Reinstall the diaphragm pump:

- 28** Mount the pump in the case of the sample gas feed unit.
- 29** Attach the hose coming from the diaphragm filter outlet to the pump inlet and the hose going to the flow meter inlet to the pump outlet. Take care not to bend or squash any hoses. Connect the pump's power supply leads.
- 30** Close and fasten the case cover of the sample gas feed unit.

Restart the sample gas feed unit:

- 31** Check gas path seal integrity (see section "Checking Gas Path Seal Integrity", page 27).
- 32** Switch on power supply to the sample gas feed unit.
- 33** The sample gas flow should only be restarted after the lead time period.

Checking Gas Path Seal Integrity

When must the gas feed path be checked for leaks?

The gas paths should be checked for leaks regularly. They must be checked after the gas paths inside the feed unit have been opened.

NOTE

The feed unit must be checked from both sample gas connections because of the valves in the built-in diaphragm pump.

Check for Leaks

- 1 Block off the sample gas outlet.
- 2 Apply a positive pressure of 100 mbar to the sample gas inlet.
- 3 Using a U-pipe manometer, for example (pipe diameter 7 to 8 mm), check the drop in pressure; this must not exceed 0.1 mbar per minute.
- 4 Similarly, check for leaks from the other side.

Troubleshooting

Problem	Cause	Corrective Action
Sample gas feed unit not working	Power supply interrupted	Reconnect the power supply.
	Fuse blown	Replace fuses.
	Pump motor blocked	Remove blockage.
	Defective pump	Replace pump.
	Defective diaphragm	Replace diaphragm (see section "Replacing the Diaphragm and Valve Plates in the Diaphragm Pump", page 24).
Drops of condensate in the condensate monitor or flow monitor (liquid alarm)	Condensate being produced by the gas analysis system	Check operability of the upstream condensate separation device, and rectify cause.
	Fluid from the process penetrating	Empty, clean and dry the upstream sample gas pipe and sample gas conditioning units.
	Sample gas cooler's condensate collecting vessel full	Empty, clean and dry the condensate monitor. Replace filter diaphragm.
		Press reset switch on the front panel to deactivate the condensate lock.
Sample gas flow insufficient (flow alarm)	Upstream sample gas line or modules blocked or closed	Remove blockage or open modules.
	Downstream modules blocked or closed	Remove blockage or open modules.
	Negative pressure on the gas sampling side	Rectify negative pressure.
	Positive pressure in the waste gas pipe	Rectify positive pressure.
Cooler not working, temperature indicator off	Fuses blown	Replace fuses.
Temperature indication > 3 °C	Power supply defective	Check voltage at filter capacitors C1 and C2.
	Fan defective	Check fan and replace if necessary.
	Ambient temperature > 45 °C	Check ambient temperature.
	Sample gas flow too high	Reduce sample gas flow.
Temperature indication = 1999	Temperature sensor defective	Disconnect white leads and measure the Pt100 sensor resistance: $107.79 + 0.4 \Omega$ at +20 °C ambient temperature. Replace sensor when deviations are larger.
Temperature indication = room temperature, LED K1 lights up constantly	Transistor T1 BUZ11 defective	Check Peltier element voltage at terminals X2-3 and X2-4 (see section "Circuit Diagrams", page 35): Voltage > 13 VDC \Rightarrow transistor defective; replace transistor T1.

CHAPTER 6**Shutting Down and Packing****Shutting Down the Sample Gas Feed Unit****WARNING**

Before the sample gas feed unit is shut down it must be purged to prevent the accumulation of condensate and deposits.

NOTE

Make sure the sample gas feed unit is free of residual moisture that can freeze if low temperatures are encountered during storage and transport. Ambient temperature during storage and transport: -25 to $+60$ °C.

Shut Down the Sample Gas Feed Unit

- 1 Disconnect the power supply.
- 2 Shut off the sample gas supply to the sample gas feed unit.
- 3 Remove the gas pipes from the connections on the feed unit.
- 4 Thoroughly purge the sample gas feed unit gas paths with an inert gas.
- 5 Fully tighten the gas connections.
- 6 Disconnect the electrical leads.

Packing the Sample Gas Feed Unit

Pack the Sample Gas Feed Unit

- 1** If the original packing material is no longer available, wrap the device in bubble foil or corrugated cardboard. When shipping overseas, also heat-seal the device air-tight in 0.2 mm thick polyethylene, including a desiccant (e.g. silica gel). The amount of desiccant used should be adequate for the package volume and the probable shipping time (at least 3 months).
- 2** Pack the device in an adequately large box lined with shock absorbent material (e.g. foam material). The thickness of the cushioning material should be adequate for the weight of the device and the mode of shipping. The box should also be lined with a double layer of bitumen paper for overseas shipping.
- 3** Mark the box "Fragile! Handle with care!".

Ambient temperature during storage and transport: -25 to $+60$ °C.

ATTENTION

Before the sample gas feed unit is returned to the service department, e.g. for repair, it must be cleaned from any contamination with aggressive or poisonous media. It has to be stated which media have been fed with the sample gas feed unit. This information is needed so that service personnel can take any requisite safety precautions for harmful gases.

CHAPTER 7
Annex

Pneumatic Diagrams

Legend

- 1** Sample gas inlet
- 2** Test gas inlet
- 3** Gas outlet
- 4** Bypass outlet
- 5** Sample gas inlet for external infeed
- 6** Test gas inlet for external infeed
- 7** Condensate inlet from the external cooler
- 8** Condensate outlet
- Not supplied:
- A** External cooler
- B** External multi-way cock
- C** External solenoid valves
- Option:
- D** Additional condensate pump for external cooler

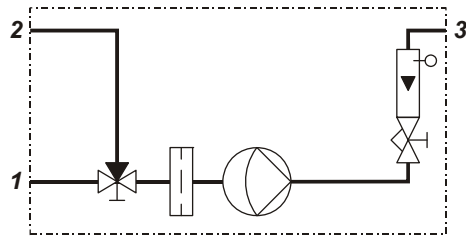
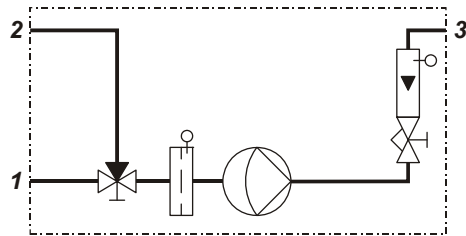
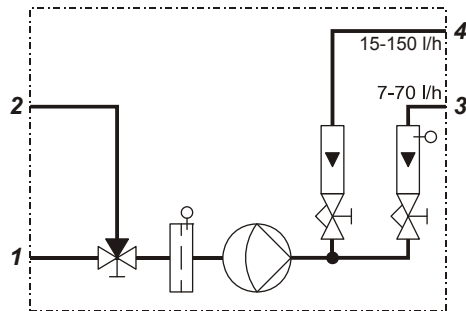
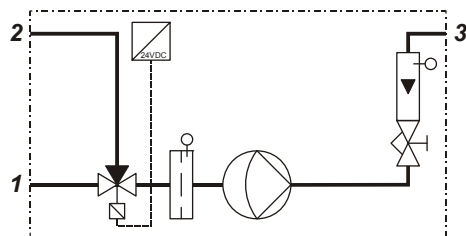
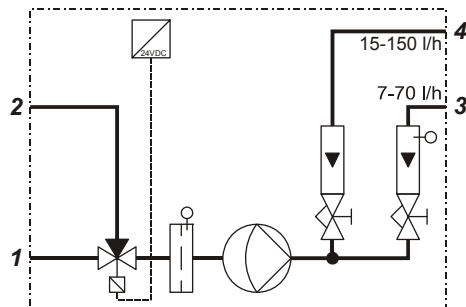
Version 1 Catalog number 23236-0-X11000XX0000**Version 2 Catalog number 23236-0-X21000XX0000****Version 3 Catalog number 23236-0-X31000XX0000****Version 4 Catalog number 23236-0-X22000XX0000****Version 5 Catalog number 23236-0-X32000XX0000**

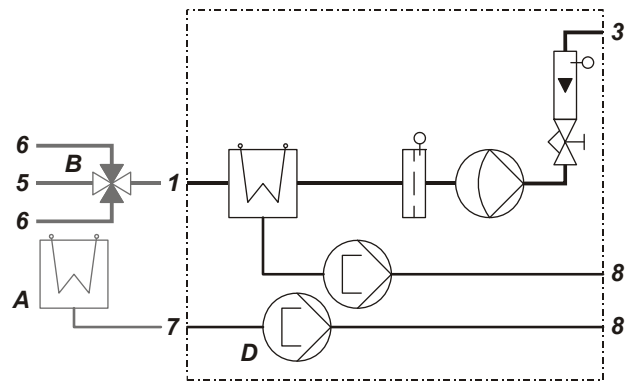
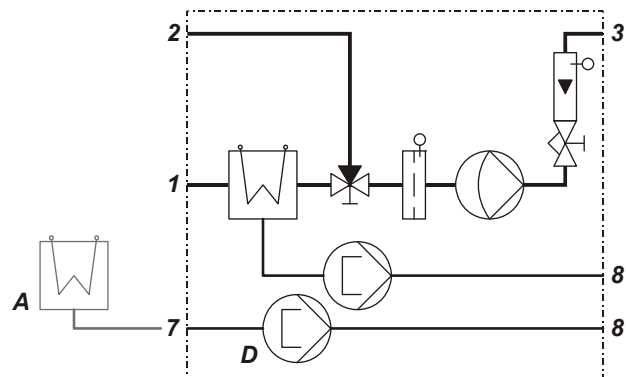
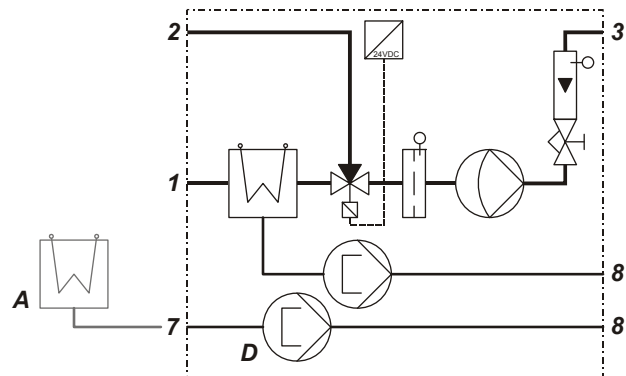
Version 6 Catalog number 23236-0-X2001XXX0000**Version 7 Catalog number 23236-0-X2101XXX0000****Version 8 Catalog number 23236-0-X2201XXX0000**

Circuit Diagrams

SCC-S Sample Gas Feed Unit without Peltier Cooler

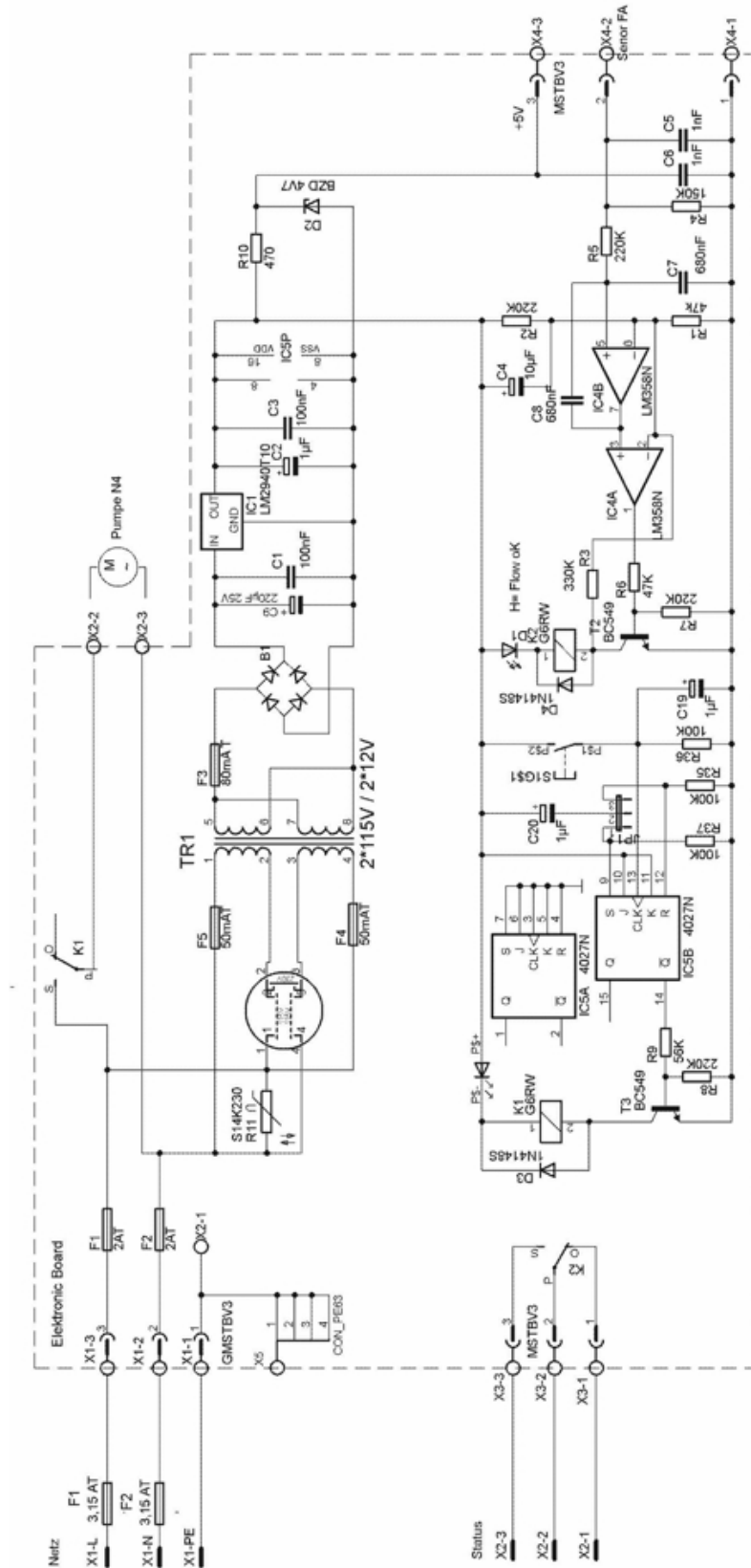

SCC-S Sample Gas Feed Unit with Peltier Cooler

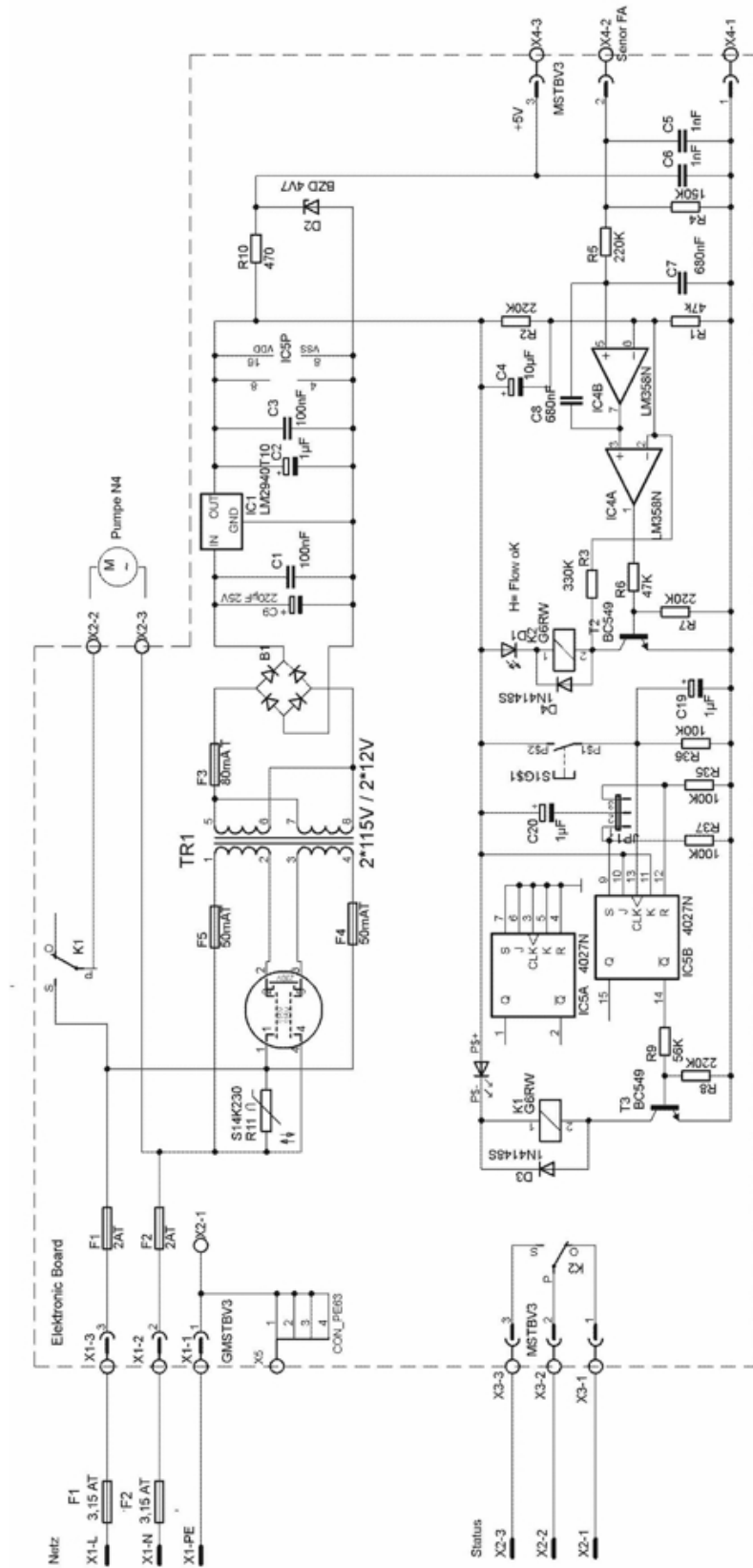

SCC-S Sample Gas Feed Unit 24 VDC Power Supply and Solenoid Valves

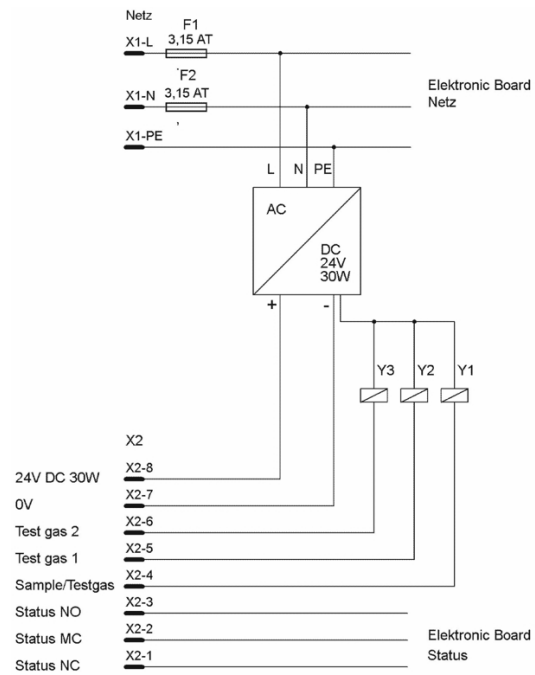

Index

A

Annex • 31

C

Checking Gas Path Seal Integrity •
26, 27

Circuit Diagrams • 35

Connecting the Electrical Leads •
14

Connecting the Gas Lines • 13

D

Dimensional Drawing • 9

M

Maintenance • 20

Mounting the Sample Gas Feed
Unit • 11

P

Packing the Sample Gas Feed Unit
• 30

Peltier Cooler Control • 19

Pneumatic Diagrams • 31

Power Supply and Sample Gas
Activation • 17

Preface • 3

Preparation for Installation • 7

R

Replacing the Condensate Pump
Hose • 20

Replacing the Condensate Pump
Pressure Rollers and Springs • 22

Replacing the Diaphragm and Valve
Plates in the Diaphragm Pump •
24

Requirements for the Installation
Site, Power Supply • 7

S

Safety Information • 4

Safety Instructions • 5

Sample Gas Feed Unit Installation •
10

Sample Gas Feed Unit Start-Up •
17

Sample Gas Inlet Conditions • 8

Sample Gas Pump Control • 18

Scope of Delivery • 8

Shutting Down and Packing • 29

Shutting Down the Sample Gas
Feed Unit • 29

Specified Use • 4

T

Troubleshooting • 28

U

Unpacking the Sample Gas Feed
Unit • 10

ABB has Sales & Customer Support expertise
in over 100 countries worldwide.

www.abb.com



ABB Automation GmbH

Analytical
Stierstaedter Strasse 5
60488 Frankfurt am Main
Germany
Fax: +49 69 7930-4566
E-Mail: cga@de.abb.com

The Company's policy is one of continuous product
improvement and the right is reserved to modify
the information contained herein without notice.

Printed in the Fed. Rep. of Germany (10.11)

© ABB 2011